

## V-2 Pneumatic Piston Pump™

# Installation Manual and Operating Instructions



<i>Inspect Shipment</i> .....	2-3
<i>Prepare to Install</i> .....	4-5
<i>Drive Motor Assembly</i> .....	6
<i>Seal Plates &amp; Cartridges</i> .....	7
<i>Install Downhole Components</i> .....	8-9
<i>Install Driver</i> .....	10
<i>Startup</i> .....	11
<i>Maintenance</i> .....	11
<i>Troubleshooting</i> .....	12-13
<i>Below-Grade Installations</i> .....	14
<i>Assembly &amp; Discharge</i> .....	15
<i>Stuffing-Box Seal Replacement</i> .....	16
<i>U-cup Seal Replacement</i> .....	17
<i>Warranty, Claims</i> .....	18-19

**\*for both Short &  
Extended versions**

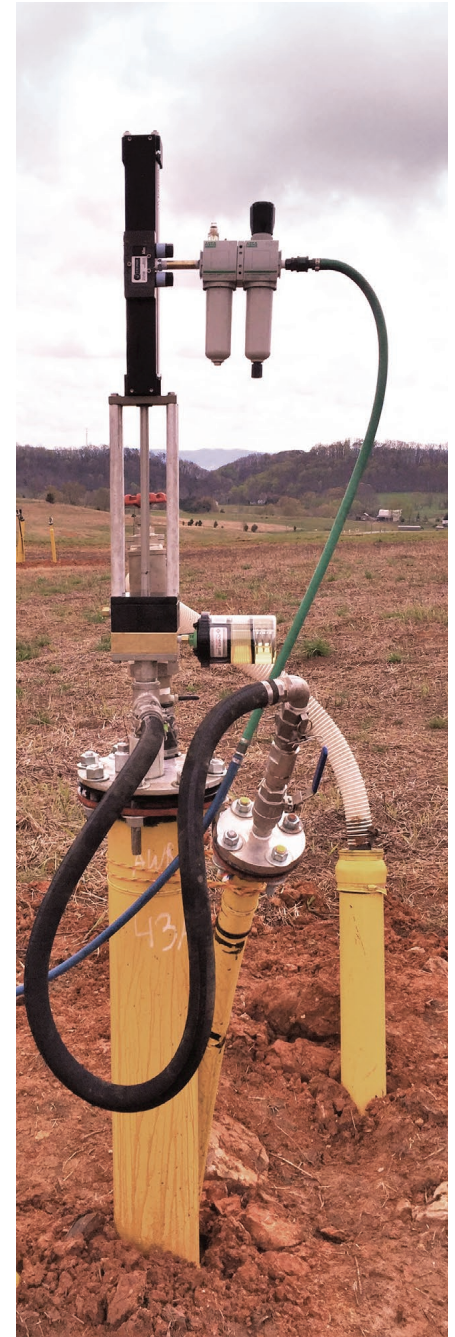

# INSPECT SHIPMENT

Examine shipped materials. Report and document any damage immediately, before installation. Keep drive motor and components in original shipping cartons until needed.

## CUSTOMER-SUPPLIED MATERIALS

### HDPE discharge installations

Blackhawk supplies HDPE to the stainless-steel transition fittings. The customer supplies the HDPE pipe.

### PVC and other hardpipe discharge installations

Blackhawk supplies the stainless-steel couplings. The customer supplies the NPT-threaded hard pipe.

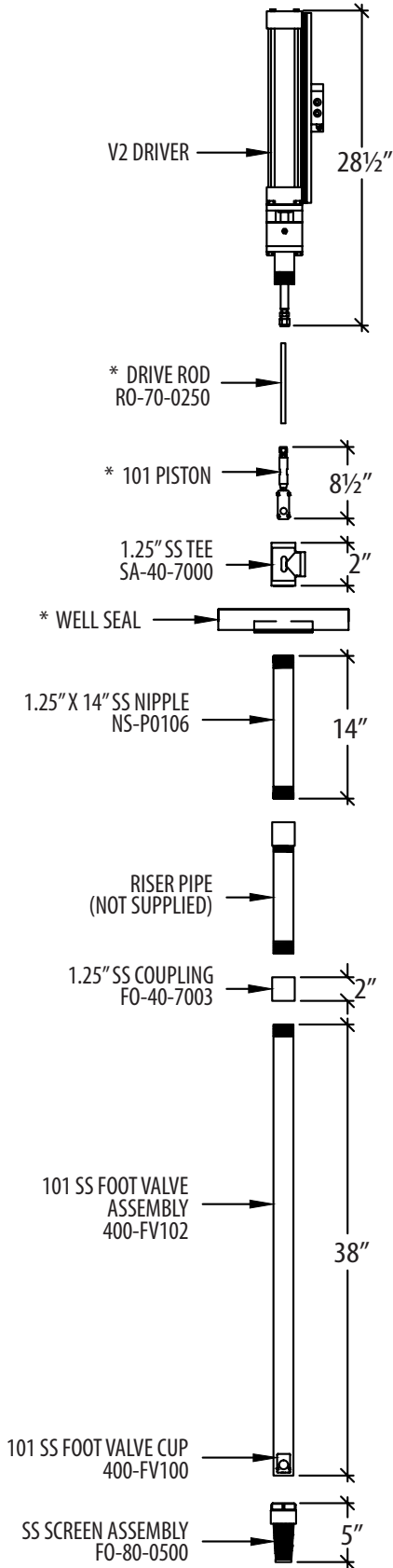

\* AVAILABLE BY ORDER



You will need (from left): Two pipe wrenches, adjustable wrench, channel lock pliers, small vice-grip pliers, ratchet wrench with 1/2-in. socket, three open-end wrenches (1/2-in., 5/8-in. and 11/16-in.), hacksaw. Also (top): Tape measure, electric tape, Teflon-type tape, silicone spray lubricant, dark-ink marker.



# INSPECT SHIPMENT

## PVC and Hard Pipe

## HDPE Heat Fusion

## PPE HDPE Compression

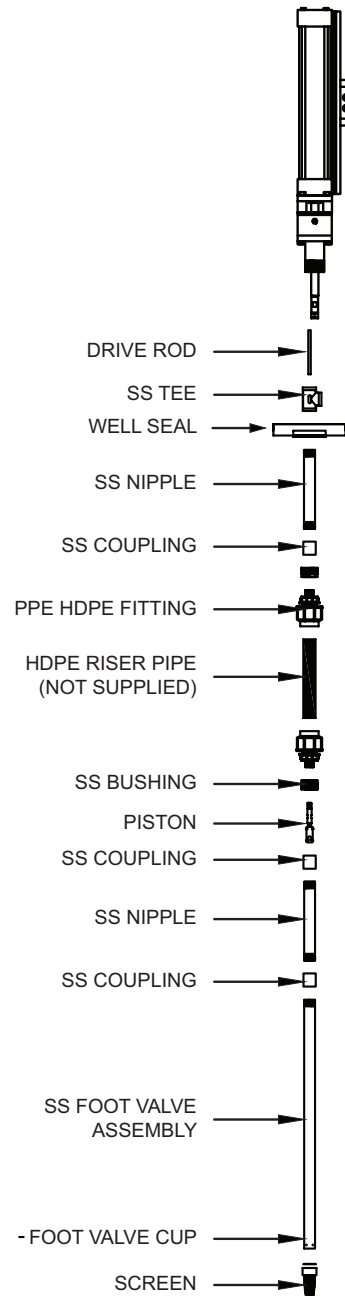
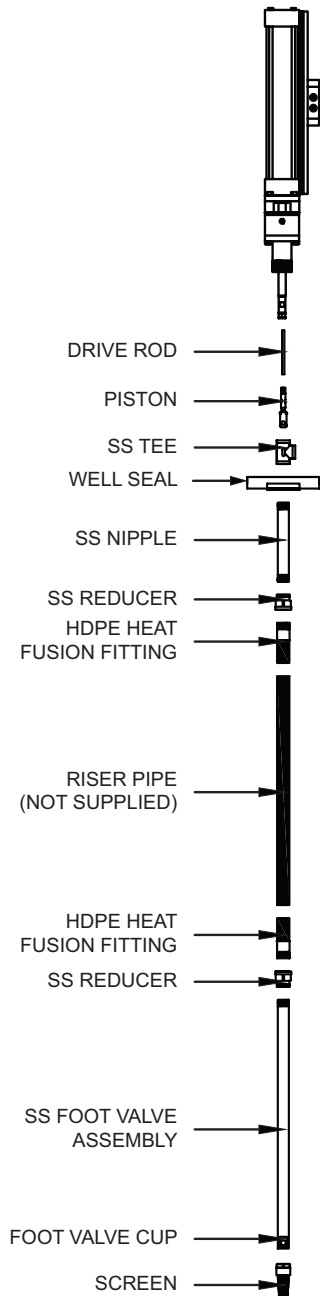
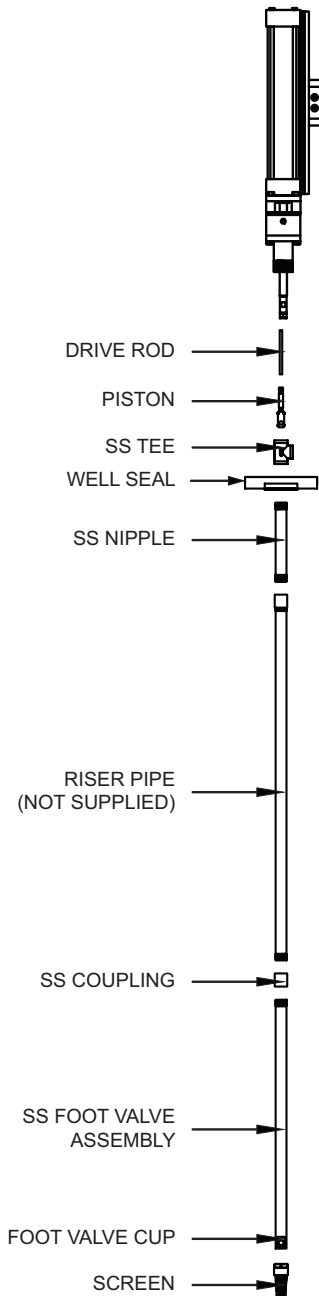



# PREPARE TO INSTALL



Lay out piston, drive rod, well seal and discharge tee. At left are foot-valve assembly and coiled HDPE riser pipe.

## A Assess well condition

A new well should be free of drill cuttings and pipe-casing debris. Check well-casing's inside diameter to make sure it is not smaller than the pump.

## B Assess fluid condition

General duty V-2 pneumatic pumps are designed for fluids to 180°F/82°C with steel pipe; with PVC pipe to 140°F/60°C. For higher-temp applications, contact Blackhawk. Fluids can be viscous and contain gas.

## C Lay out downhole components

1. Remove from packaging: Downhole assembly, well seal, drive piston, discharge tee, pipe nipple, connectors, coiled HDPE riser pipe.
2. Carefully uncoil fiberglass drive rod. CAUTION: Rod coil is under tension. Uncoil in open area. Wear safety glasses and gloves.
3. Connect piston to drive rod. Rod should come with a nut and ferrule installed on one end. Strenuously tighten the nut to the piston assembly. Ferrule must be crimped or mushroomed into rod.
4. Lay out rod with attached piston, well seal, discharge tee, nipple, riser and other parts.

### Assemble piston to drive rod

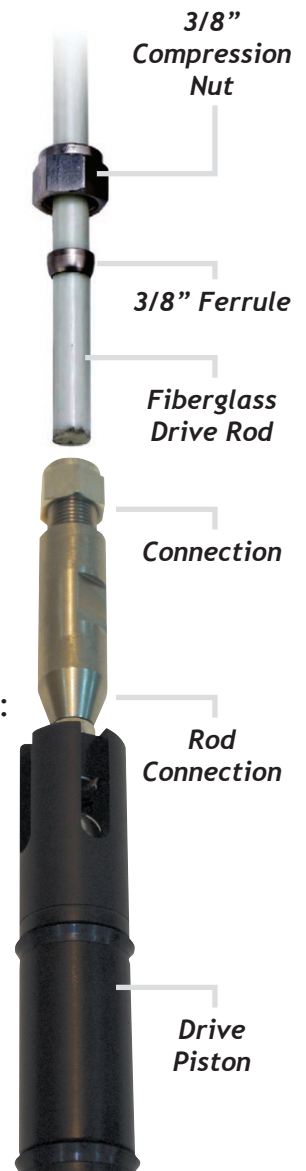

Discharge tee, well seal, pipe nipple, drive rod.

# PREPARE TO INSTALL

## **D Determine installation depth – Critical**

You must be certain of the well depth and static water level in the well to ensure accurate bottom settings for the pump intake. Improper settings can impede operations, damage the pump and invalidate the warranty. To determine depths:

1. Feed piston and rod into well casing (see photo). Stop when piston reaches bottom.
2. Determine desired depth of pump above well bottom. Note that silt and sediment near well bottom can clog intake. Pump's end point should be several feet above well bottom.
3. Pull rod up the desired length; mark rod.



Fit rod into well casing. Stop when piston reaches bottom.

## **E Power supply**

The V-2 driver will operate between 40 psi and 120 psi of pneumatic air.

# DRIVE MOTOR ASSEMBLY

## V-2 SHORT

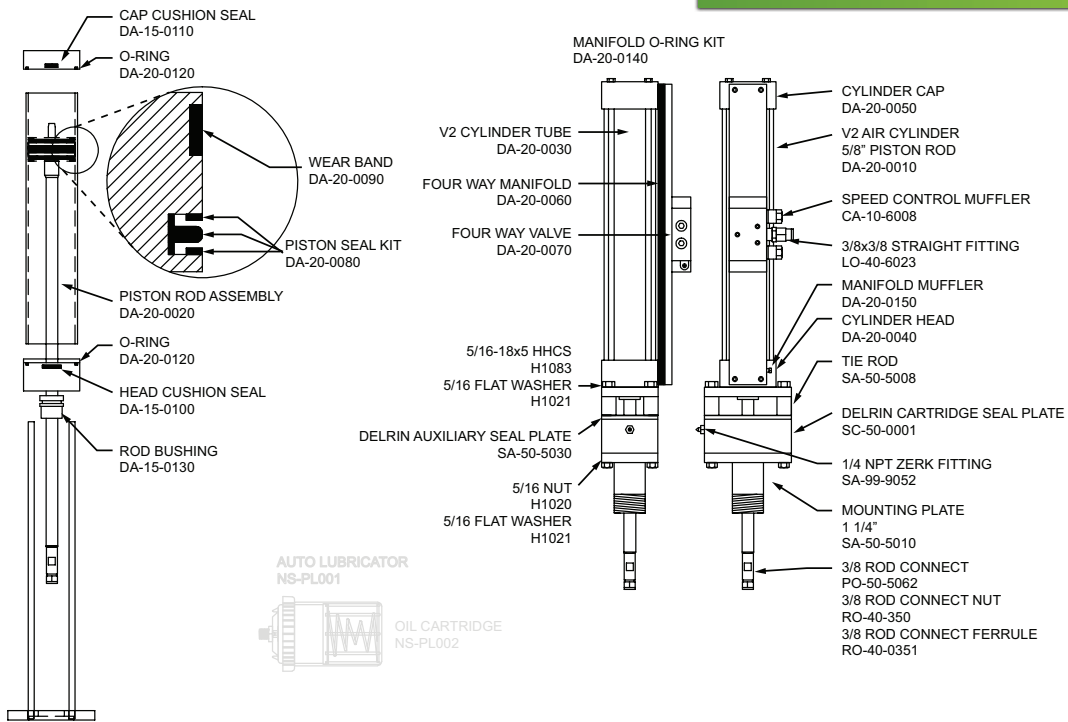

## V-2 EXTENDED HIGH TEMP

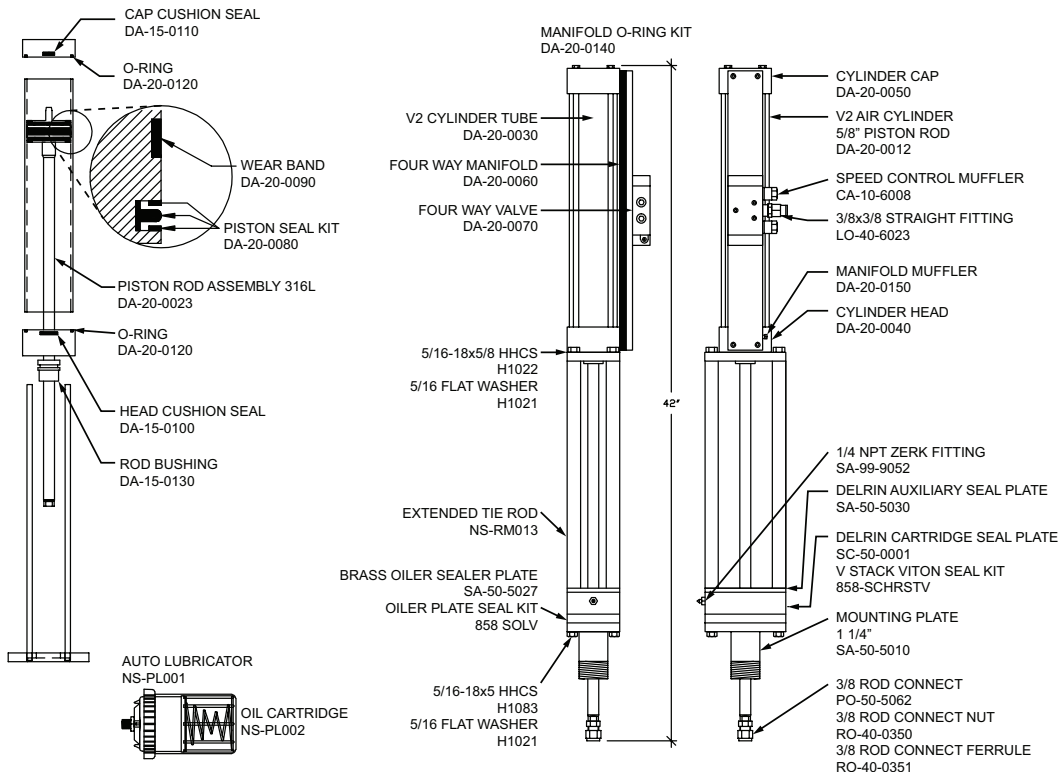



# SEAL PLATES & CARTRIDGES

## 5/8-IN. HAT RING - REGULAR DUTY

Hat Ring Seal Kit  
 858-SCHRB (Buna)  
 858-SCHRV (Viton)

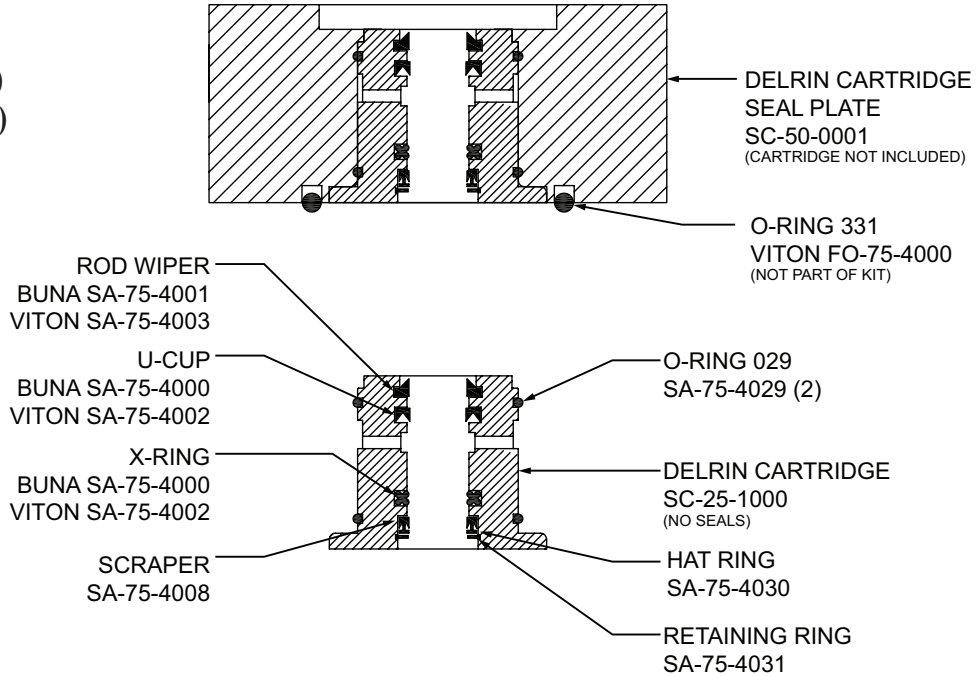

## 5/8-IN. V-STACK - HEAVY DUTY

V-Stack Seal Kit  
 858-SCHRSTB (Buna)  
 858-SCHRSTV (Viton)

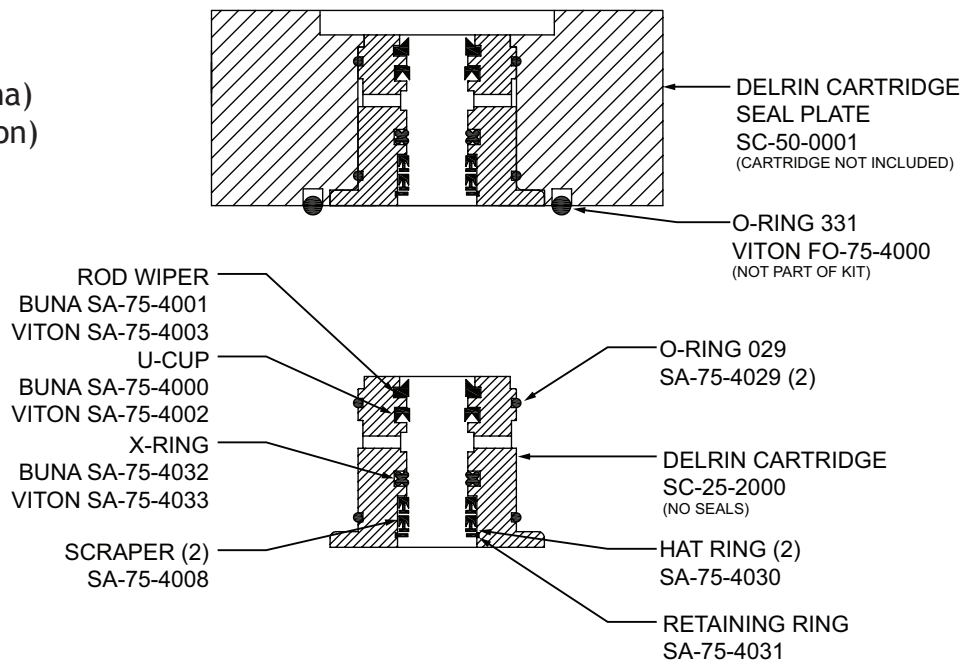

How to replace seals: Page 16

# INSTALL DOWNHOLE COMPONENTS

1. Lay out downhole components and determine installation depth (see page 4)
2. Determine length of riser pipe.  
(See drawing at right.)
  - a) Important: Measure the combined length of foot valve and strainer screen, including their fittings. Then add length of pipe nipple, plus desired distance from well seal to well bottom.
  - b) Subtract that combined number from well depth.
3. Assemble downhole components (see Page 2 drawing).
  - a) Apply Teflon tape or equivalent to threads during assembly.
  - b) Insert pipe nipple through bottom of well seal.
  - c) Insert discharge tee through top of seal. (See Page 9 photo)
4. Open well; Prepare wellhead by removing all debris, caps or other enclosures. Casing must be at proper height to allow well installation and servicing, generally no higher than 4 feet (1.2 meters).
5. Install downhole assembly, foot-valve assembly first, into well casing. (See Page 9 photo).

## How to Measure Riser-Pipe Lengths

- Add together length of nipple (N), length of foot valve assembly with strainer (F) and desired distance from bottom of pump to bottom of well (D).
- Subtract that number from the distance between well seal and well bottom (W).

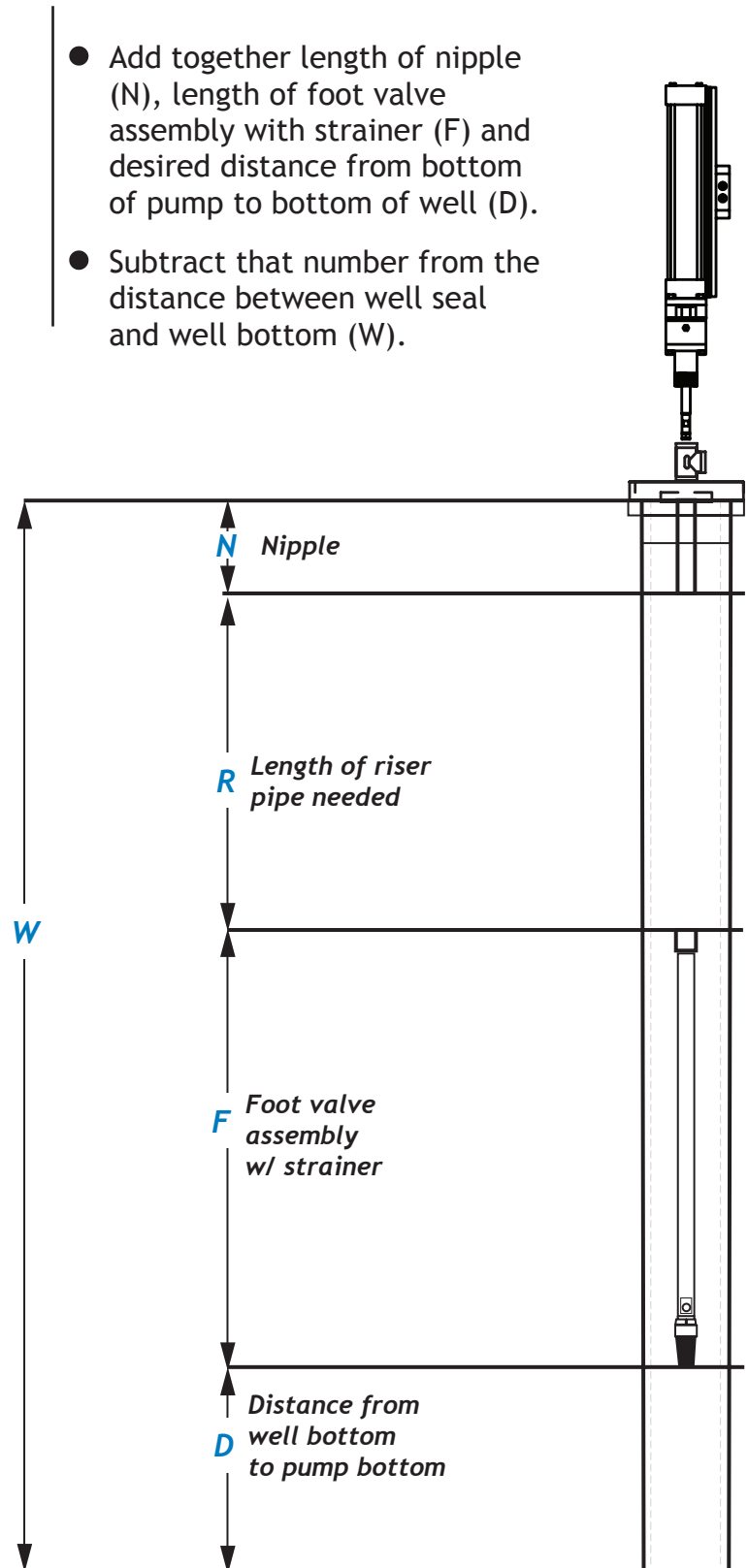



# INSTALL DOWNHOLE COMPONENTS



Feed downhole assembly, foot-valve first, into well casing.

- Piston now should be connected to fiberglass drive rod. If not, see Page 4. Be careful. If still coiled, rod is under tension and can be dangerous if not properly handled.
- Insert piston and drive rod into riser assembly. Gradually feed rod through the riser pipe toward the foot-valve assembly.

(NOTE: If riser pipe assembly is sufficiently larger than piston, the piston and rod can be installed through the discharge tee at surface.)

- Firmly grip the drive rod. Pump by hand to fill the riser with liquid. This step ensures the piston is correctly positioned in the foot-valve assembly.
- Make certain the piston has bottomed out in the foot valve. Mark the rod at the top of the tee.

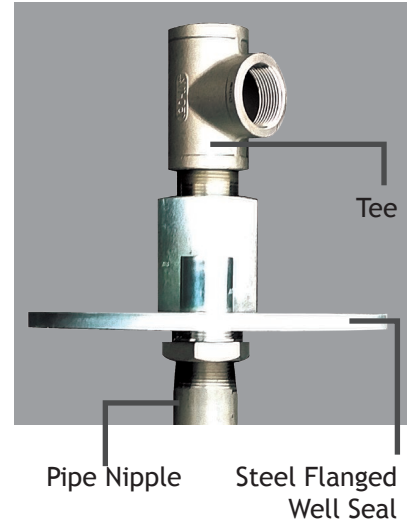

## Straight Flanged

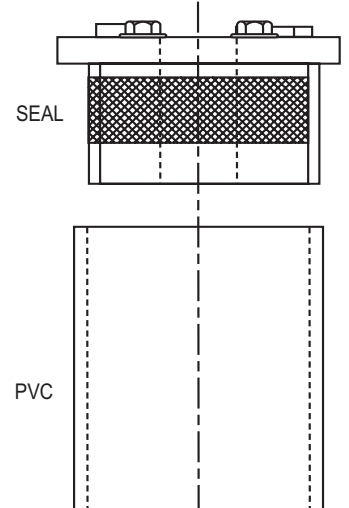

## Flanged Gas Well

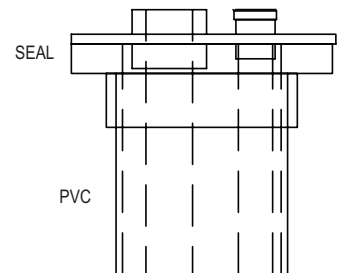

## Rod Attaches to Drive Motor

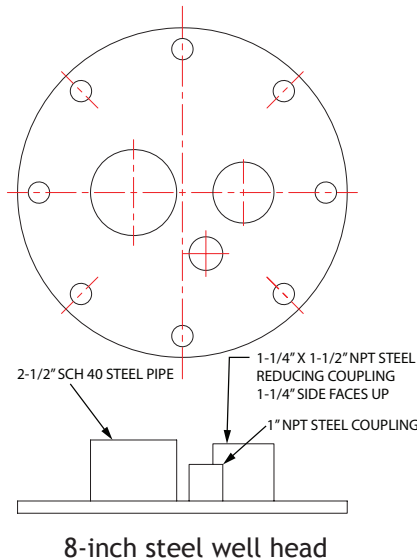
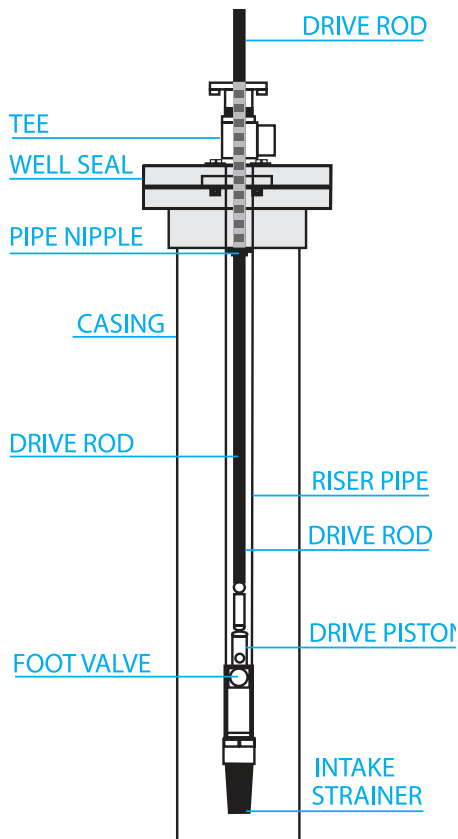

# INSTALL DRIVER

1. Pull up the drive rod; note mark on tee (Page 9, Step 9)
2. Mark the rod again, 20 inches below first mark. See drawing below.
3. If the drive rod cannot be removed from the riser, lightly clamp vice-grip pliers to the rod to prevent it from slipping back into the riser.
4. With hacksaw, cut rod at the lower mark.  
Cut all the way around rod to prevent splintering.
5. Install nut and ferrule on rod, if necessary. Insert rod into driver coupling. Strenuously tighten nut to coupling. The ferrule must be crimped or mushroomed into the rod.  
Reconnect rod to drive motor.
6. Before attaching driver, see System Startup (Page 11)

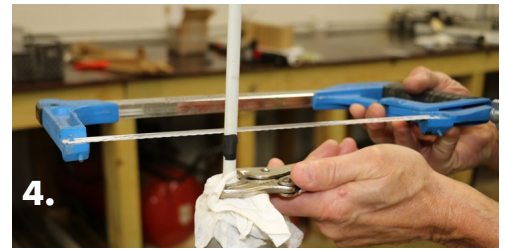
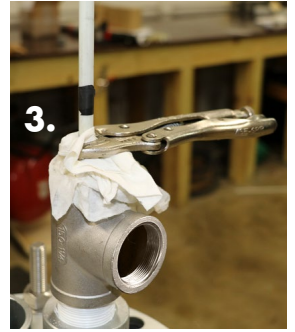

## Rod-cutting Instructions

Piston must bottom out in foot valve (Fig. A).  
Mark rod at top of tee with dry marker (Fig. B).  
Cut rod 20 inches below mark (Fig. C).  
The cut rod should extend above tee (Fig. D).

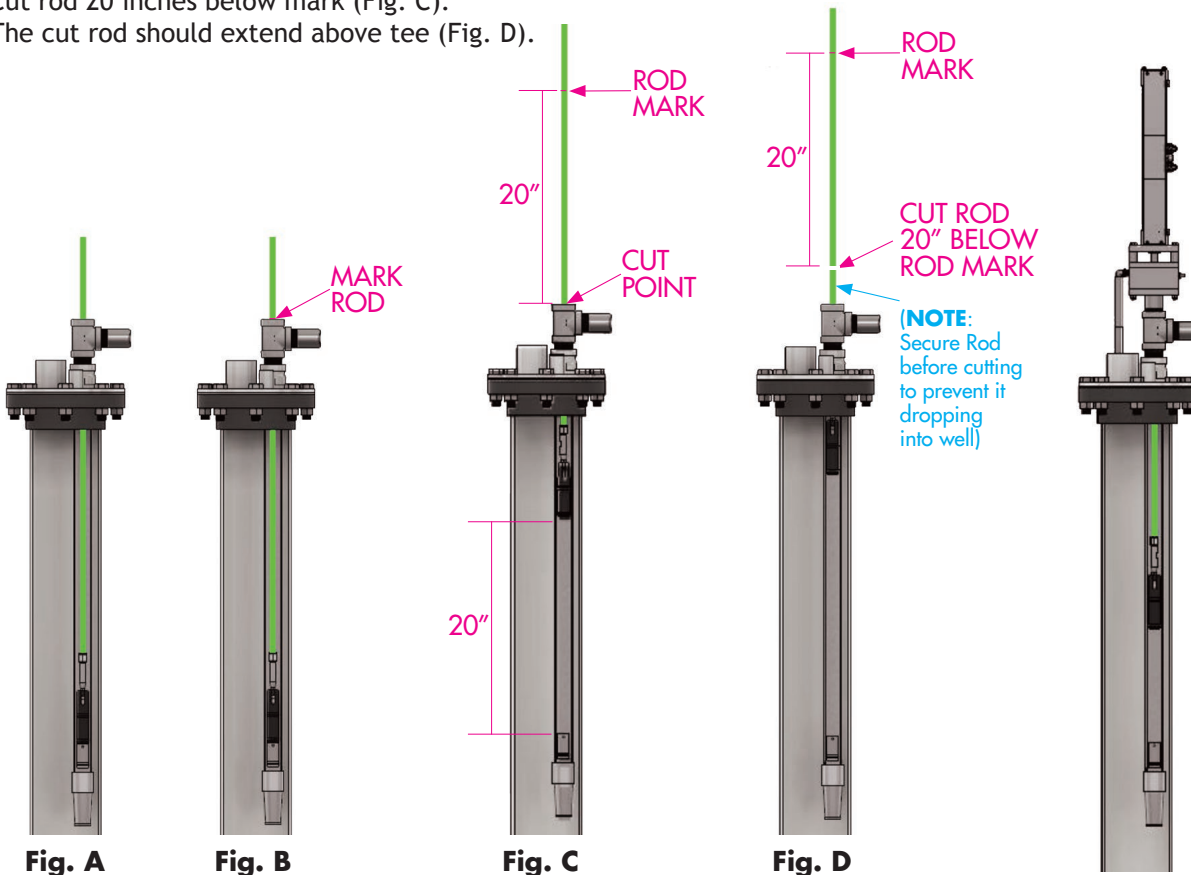

Fig. A

Fig. B

Fig. C

Fig. D

(NOTE:  
Secure Rod  
before cutting  
to prevent it  
dropping  
into well)

# STARTUP & MAINTENANCE

## SYSTEM START UP

1. Attach temporary hose to discharge tee. Drain liquid into large receptacle for disposal.
2. Connect air supply to regulator's push-to-connect fitting.
3. Turn on air supply; set regulator to between 40 psi and 100 psi. Pressure will depend upon depth of well/sump and fluid viscosity.
4. Adjust air-valve's speed mufflers with Allen wrench to roughly 10 strokes per minute. For best performance, adjust speed mufflers equally.
5. Operate pump until liquid runs fully clear of sand and silt.
6. Adjust and balance speed mufflers to desired stroke rate; 20 strokes per minute is optimal for long pump life. Do not exceed 40 spm.
7. Turn off air supply. Complete all permanent discharge connections.

**CRITICAL:** Never operate pump with discharge valve closed or discharge pipe clogged. This will cause seal and system failure, potential damage or injury, and will void warranty.

8. Start pump; check stroke rate.

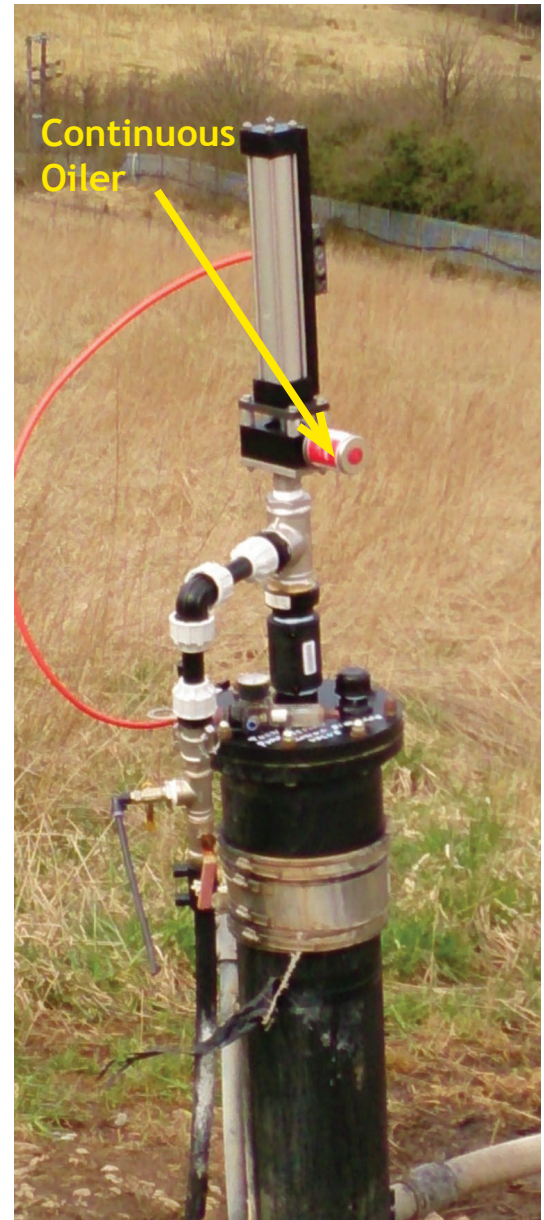

Attach continuous rod oiler to seal plate.

## REQUIRED MAINTENANCE

1. Check pump periodically for pressure, draw down, cycle rate and performance.
2. Visually inspect pump. Make sure polished metal drive rod is clean and free of dirt, stains and sticky residue.
3. Check for adequate liquid discharge.
4. Lubrication required to avoid drive-motor failure. Attach continuous rod oiler to seal plate - strongly recommended. Waterproof lithium grease may be injected lightly into Zerk fitting, but do not over-grease - no full strokes.

# TROUBLESHOOTING

## OBSERVATION

## CAUSE

## SOLUTION

- Pump not operating

- No power.
- Restricted liquid discharge.
- Piston drive disconnected.

- Check to see that the power supply is on, and that all connections are sound
- Open discharge valve.

- Pump driver operating (cycling), but not pumping liquid.

- Restricted liquid discharge.
- Piston drive disconnected.

- Check for closed valve, clogged discharge or any other obstruction.
- Remove obstruction and restart pump.
- Make sure drive rod is connected.
- If separated at compression fitting, a replacement drive rod ferrule will be required. (Ferrules cannot be re-crimped).

- Driver cycles properly but pump not pumping liquid.

- Plugged bottom intake.

- Disconnect liquid discharge hose/pipe from pump's discharge tee. Hold latex glove (or other inflatable object) over discharge tee mouth. Seal with a tight grip. Allow pump to operate. If no discharge, raise pump strainer from mud.

- Glove does not inflate or deflate as pump cycles.

- Downhole drive rod may have been cut incorrectly.
- Riser pipe string may have a leak.
- Drive rod disconnected from drive motor.
- Check balls do not seal.

- Remove and re-cut or adjust rod length as per installation instructions.
- Check pipe connections and check for cracks or leaks. Repair or replace compromised pipe or fittings.
- Pull piston and inspect check balls.

- Glove inflates more and more as pump cycles.

- No liquid at pump intake (downhole) to pump.

- Check to make sure that there is liquid to pump.





# TROUBLESHOOTING

## OBSERVATION

- Glove inflates on up stroke and deflates on down stroke, and does not inflate more and more with every stroke.

- Foot valve assembly/pipe string not water tight.

- Water stays in riser pipe (and drive rod and drive piston have been deemed OK).

- Drive rod/drive piston assembly tough to remove from foot valve assembly riser pipe. Suction pull back.

- Pump driver moving erratically when operating.

## CAUSE

- Plugged intake

- With drive rod and drive piston out of riser pipe, fill riser pipe with water. Water drains out quickly.

- Foot valve assembly/pump intake clogged.

- Pump intake may be clogged.

- Loose connections.

- Downhole drive rod length incorrect.

## SOLUTION

- Raise pump

- Remove riser pipe and foot valve assembly and inspect, replace, and/or repair.

- Remove riser pipe and foot valve assembly and inspect. Clean piston and foot valve. Raise pump out of mud.

- Follow directions for clogged intake foot valve.

- Check all connections to be sure they are tight.

- Check rod length and adjust as per installation instructions.

# BELOW-GRADE INSTALLATIONS

## FLEXIBLE-HOSE DISCHARGE ADAPTOR

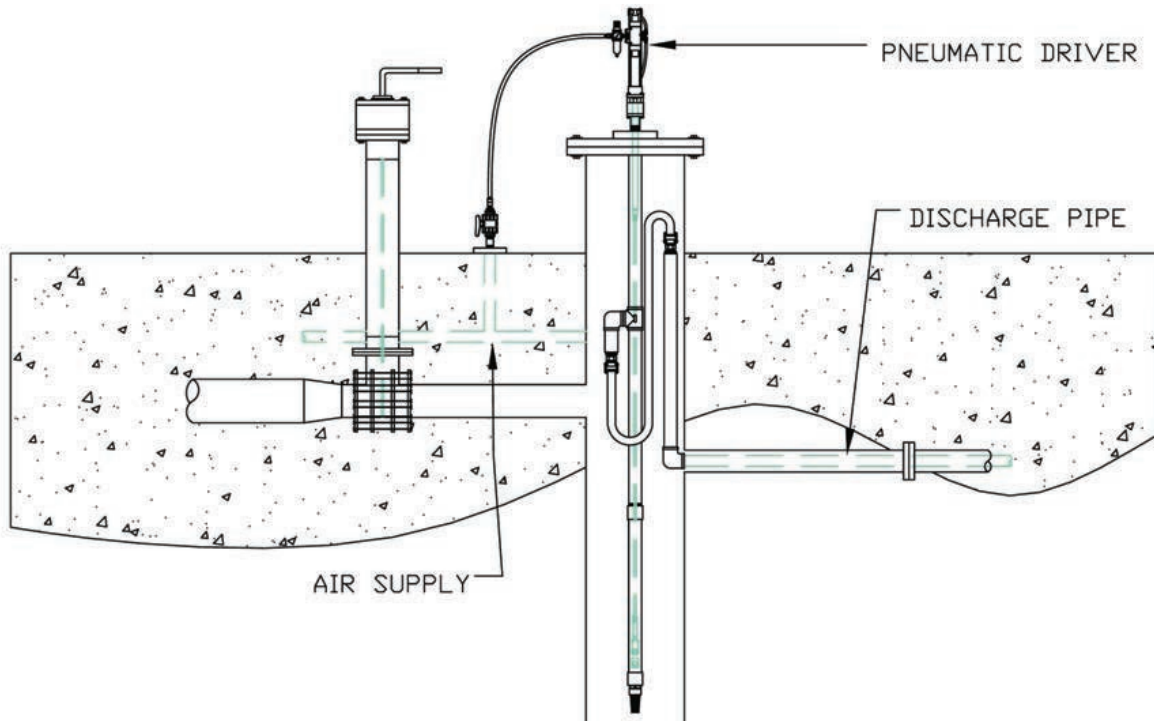

## PITLESS DISCHARGE ADAPTOR

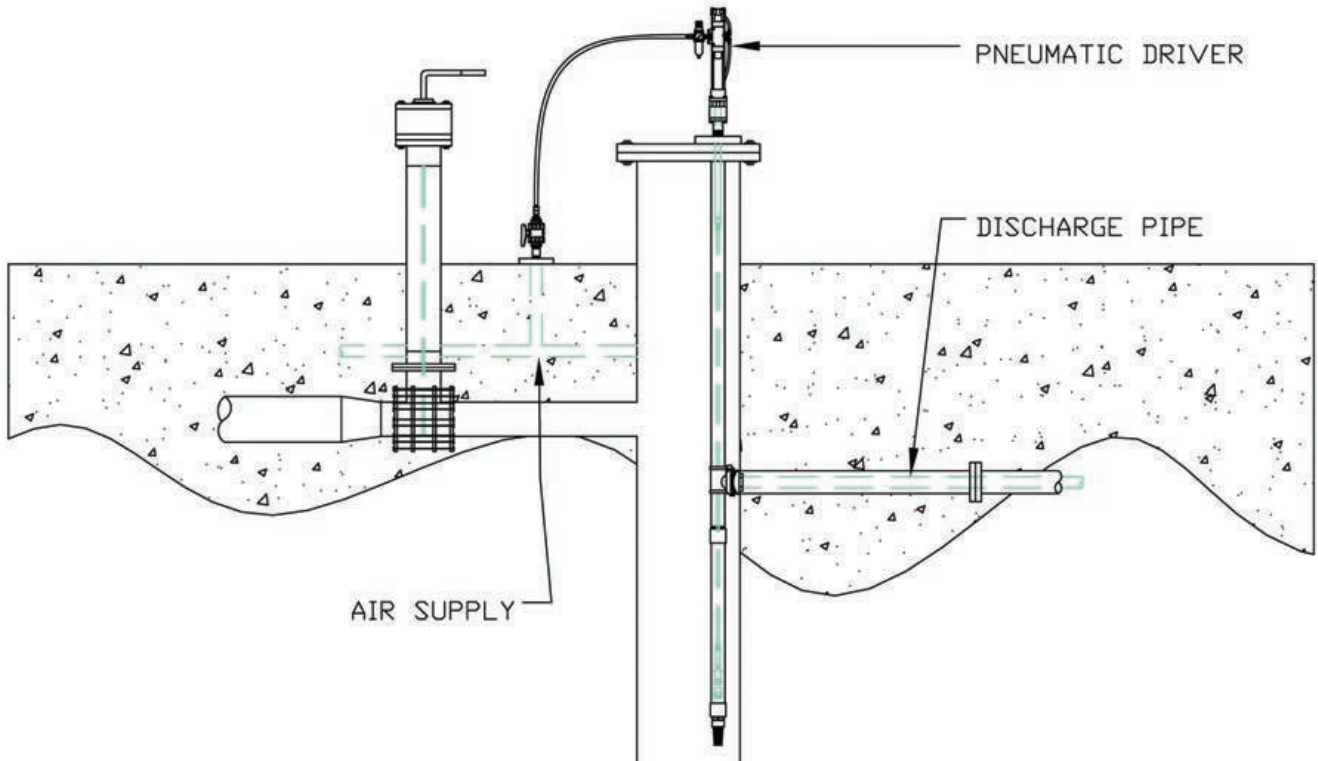

# ASSEMBLY & DISCHARGE

## ASSEMBLY WITH ACCESSORIES

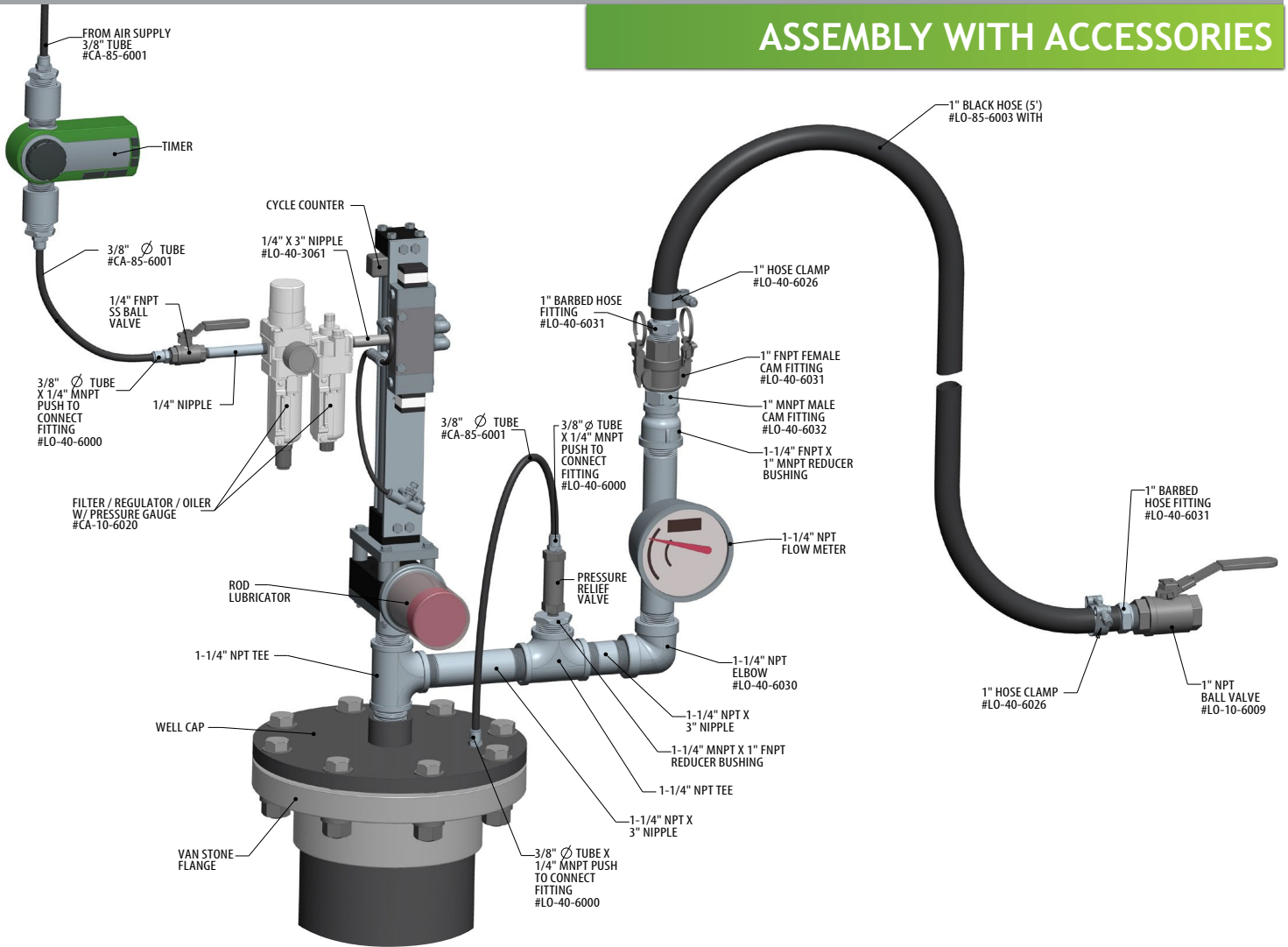

## SIDE-SLOPE INSTALLATION

With or without stinger extension

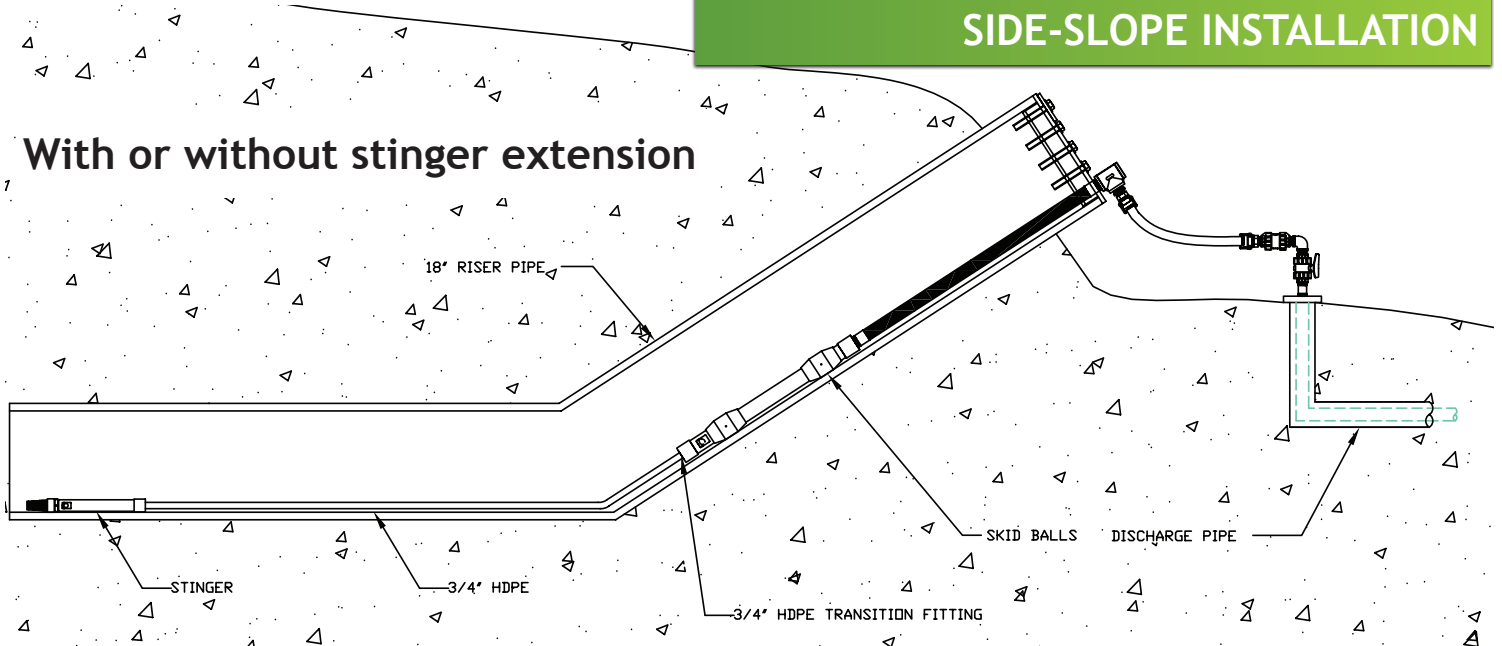

# HOW TO REPLACE STUFFING-BOX SEALS

- 1) Push out cartridge from seal block.
- 2) Remove two outside O-rings.
- 3) Remove rod wiper. Use pick tool to snag seal and pull from groove.
- 4) Flip cartridge over. Use small, thin-blade screwdriver to remove split (retaining) ring.
- 5) With same screwdriver, remove Variseals and Hat Rings.  
*Go to Step 7*
- 6) Using dental-style pick tool, remove X-rings, backup rings.  
*Go to Step 7*
- 7) Soak cartridge in paint thinner 30 minutes.
- 8) Clean grooves with fine wire brush; be careful to avoid marring.
- 9) Soak in green or orange grease cutter 30 minutes.
- 10) Rinse thoroughly with water.
- 11) If cartridge not fully clean, repeat steps 8-10. Dry.
- 12) Install new seals in inverse order from above - refer to cartridge drawing.
- 13) Push clean cartridge back into block.

## For V-Stack™ cartridge only:

## For Hat Ring® cartridge only:



NOTE: A Blackhawk technician will replace seals and clean cartridges in our factory at low cost with quick turnaround, returned good as new: 800-469-4887, [dparison@blackhawkco.com](mailto:dparison@blackhawkco.com).



Replace clean cartridge

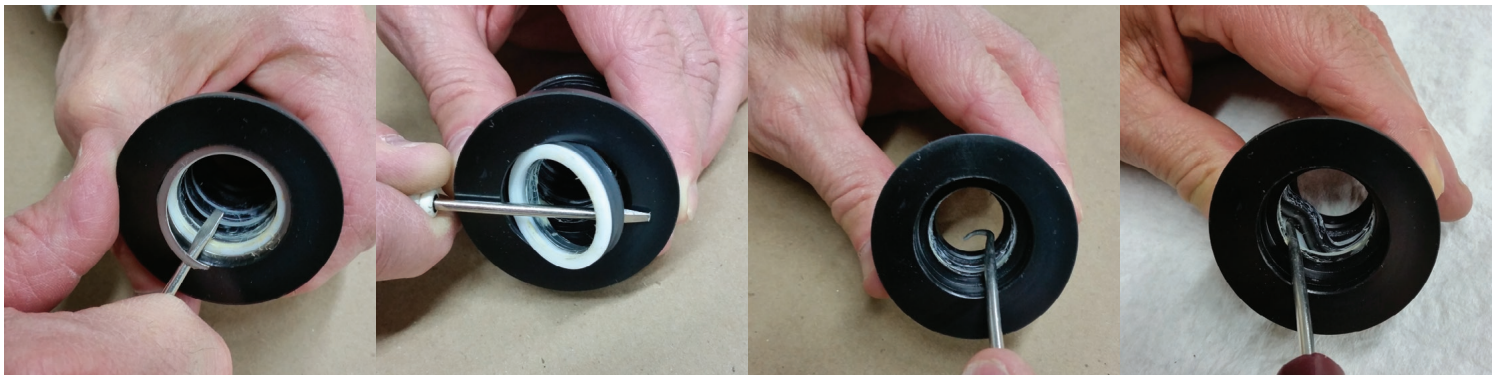

Remove split ring

Remove Variseal(s)

Pick tool

Pull X-rings





# How to Replace U-Cup Seals in HTCR Pistons

Heavy-duty, flexible U-Cup piston seals for High-Temperature Corrosion-Resistant (HTCR) pumps are easy to replace if necessary. Procedures are the same for brass, PEEK and Delrin pistons.

## REMOVE



1. Insert flat blade of small screwdriver under seal.



2. Push blade underneath and through seal to bring it up from groove.



3. Work blade around piston to remove.



4. Repeat for second seal.

## REPLACE



5. Clean piston before inserting; press seal into groove.



6. Insert screwdriver through seal.



7. Work back around.



8. Check both seals for uniform fit

**NOTE:** A Blackhawk technician will replace piston and cartridge seals and clean cartridges at our factory at low cost with quick turnaround, returned good as new: 800-469-4887, [dparison@blackhawkco.com](mailto:dparison@blackhawkco.com).

# WARRANTY, TERMS, & CONDITIONS

## Limited Warranty

Pumps (excluding seals) manufactured by Blackhawk Technology Company (Blackhawk) are warranted, to the original user only, to be free of defects in material and workmanship for one year from the date of invoice.

## Terms and Conditions

Final delivery date will be determined at time of order. All prices are in U.S. dollars, F.O.B. Glen Ellyn, IL USA. A copy of Buyers Purchase Order is required at time of order. "Delivery time on all specials will be determined after receipt of order." Terms are Net 30 days. Total quoted price does not include freight charges. Freight will be prepaid and added to Blackhawk Technology's final invoice to buyer. A service charge of 1.5% per month will be applied to all past-due invoices. Pricing is valid for 30 days. Notwithstanding anything contained herein to the contrary, the parties agree that the terms and conditions set forth in the limited warranty of Blackhawk Technology Company shall supersede any of the terms and conditions otherwise set forth.

Blackhawk's liability under this warranty shall be limited to repairing or replacing at Blackhawk's option, without charge, F.O.B. Blackhawk's factory, any product that Blackhawk manufactures. Blackhawk will not be liable for any costs of removal, installation, transportation or any other changes that arise in connection with a warranty claim. Products that are sold but not manufactured by Blackhawk are subject to the warranty provided by manufacturer of said products and not by Blackhawk's warranty. Blackhawk will not be liable for damage or wear to said products by abnormal operating conditions, accident, abuse, misuse, unauthorized alteration or repair, or if the product was not installed in accordance with Blackhawk's printed installation and operating instructions.

To obtain service under this warranty, the defective product must be returned to Blackhawk together with proof of purchase and installation date, failure date, and supporting installation data. Unless otherwise provided, contact will be made to Blackhawk for instructions prior to return of defective product. Any defective product to be returned to Blackhawk must be sent freight prepaid; documentation supporting the warranty claim/or a return Material Authorization must be included if so instructed.

Blackhawk will not be liable for any incidental or consequential damages, losses, or expenses arising from installation, use, or any other causes. There are not expressed or implied warranties, including mechanical ability of fitness for a particular purpose, that extend beyond those warranties described or referred to above.

Some jurisdictions do not allow the exclusion or limitation of incidental or consequential damages, and some jurisdictions do allow limitations on how long implied warranties may last. Therefore, the above limitations or exclusions may not apply to you. This warranty gives you specific legal rights and you may also have other rights that vary from jurisdiction to jurisdiction.



# WARRANTY CLAIM PROCEDURE

In the event of perceived failure of a Blackhawk Technology Company product, please follow this warranty claim procedure:

1. Verify that the problem is due to the suspected product and not another part of the system. You may call Blackhawk technical support for advanced troubleshooting assistance.
2. If you confirm that a Blackhawk product is defective, detail in writing the exact nature of the failure.
3. The product must be accompanied by notation of a dated proof of purchase, installation date, failure date and supporting installation data that are satisfactory to Blackhawk.
4. Return the product, the written description of the failure, and supporting notation to Blackhawk's home office, 21W211 Hill Avenue, Glen Ellyn, IL 60137, along with your address and a daytime phone number. Purchaser must prepay all delivery costs or shipping charges, as well as any other charges encountered in shipping any defective Blackhawk product under this warranty policy. No shipment will be accepted collect.
5. Any return from Blackhawk will be sent via Blackhawk's preferred shipping agent. Special shipping arrangements are available at the customer's expense.

Questions? Call Blackhawk's info hotline at 800-469-4887.

