

Geotech Sipper

Installation and Operation Manual



Table of Contents

DOCUMENTATION CONVENTIONS	2
Section 1: System Description	5
Function and Theory	5
Sipper Operation	5
Recovery Rates.....	6
Antenna	7
Section 2: System Installation	8
Installation of the Solar Sipper	8
Solar Panel Location	8
Mounting the Control Panel	10
Solar Sipper Wiring	11
AC Sipper Wiring.....	12
Grounding.....	13
Connect All Tubing Runs	13
Deploy the Stainless Steel Pump and Skimmer	13
Product Recovery Tank.....	14
Installation Guide: Desiccant Dryer Kit for Geotech Sipper (Solar or AC)	16
Desiccant Maintenance.....	17
Section 3: Timer/Cycle Settings and Display Descriptions	18
Setup Displays	18
Start (Runtime) Displays	19
Stopping Sipper Operation (Runtime).....	21
System Status and Diagnostic Displays	21
Alarm (Condition) and Fault Displays	25
PCB Damage	26
Optional Conductivity Sensor.....	27
To configure the GECM	27
Fault and Tankfull Dry Contact Relay (Equipped on 1-6 Well Systems).....	28
Section 4: System Operation	31
Establishing the Product Recovery Cycle Time.....	31
Initiating the Sipper Runtime.....	32
Fluid Viscosity	33
Recovery Tank is Full.....	34
Cycle Priority	34
Section 5: System Maintenance.....	37
Sipper Controller	37
Stainless Steel Pump and Skimmer	38
Solar Panel.....	38
Solenoid Maintenance (Stuck Solenoid).....	39
Optic Fluid Sensor Install/Replacement.....	42
Section 6: System Troubleshooting	44
Section 7: System Specifications	48
Section 8: System Schematics	50
Section 9: Parts and Accessories.....	60
Sipper Pump and Skimmer Parts and Accessories	61
The Warranty.....	65

DOCUMENTATION CONVENTIONS

This manual uses the following conventions to present information:



WARNING

An exclamation point icon indicates a **WARNING** of a situation or condition that could lead to personal injury or death. You should not proceed until you read and thoroughly understand the **WARNING** message.



CAUTION

A raised hand icon indicates **CAUTION** information that relates to a situation or condition that could lead to equipment malfunction or damage. You should not proceed until you read and thoroughly understand the **CAUTION** message.



NOTE

A note icon indicates **NOTE** information. Notes provide additional or supplementary information about an activity or concept.

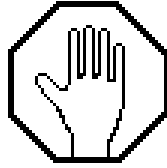

In order to ensure your Solar Sipper has a long service life and operates properly, adhere to the following cautions and read this manual before use.

- **Controller power input source must not exceed specified ratings.**
- **Controller may not operate properly with wiring not supplied by manufacturer.**
- **Avoid spraying fluid directly at controller.**
- **Never submerge controller.**
- **Avoid pulling on wires to unplug controller wiring.**
- **Avoid using a controller with obvious physical damage.**
- **To prevent damage, DO NOT drop the controller.**



WARNING

Do not operate this equipment if it has visible signs of significant physical damage other than normal wear and tear.

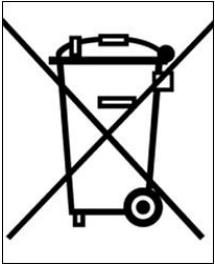

Notice for consumers in Europe:

This symbol indicates that this product is to be collected separately.

The following applies only to users in European countries:

- This product is designated for separate collection at an appropriate collection point. Do not dispose of as household waste.
- For more information, contact the seller or the local authorities in charge of waste management.

Section 1: System Description

Function and Theory

The Geotech Solar Sipper (Sipper) is a unique solar powered hydrocarbon recovery system used for operating an active down well remediation pump with an attached Skimmer. It is designed for applications where electrical power is not available or not economically feasible. Electrical power used to run the Solar Sipper is generated on-site by solar panels. The internal compressor is capable of producing up to 20" (51 cm) Hg vacuum and 100 PSI (6.9 bar) pressure. This alternating vacuum/pressure process allows the user to recover a wide range of fluids, from very viscous to ultra-light Non-Aqueous Phase Liquid (NAPL), from depths as deep as 180' (4.6 m) below ground surface. Optional multiple channel controllers can operate up to seven (7) pumps in separate recovery wells.



In this manual, a stainless steel pump with Skimmer, or any other down well assembly used with a Sipper system, will be referred to as a pump. A chart containing a range of viscous products can be found in *Section 4: System Operation*.

The standard Solar Sipper uses a 12VDC, 75-amp hour battery that is charged with an attached 85-Watt solar panel. Systems can be expanded to utilize several solar panels and larger capacity batteries. Multiple channel controllers can be implemented in areas where there are multiple recovery wells within close proximity of each other. The Sipper operates up to seven (7) wells per controller.

In general, Geotech recommends a maximum distance of 500' (152 m) (including the well depth) between the Sipper controller and the pump. Longer runs can be accommodated but are not recommended. Careful consideration must be given to additional power requirements as well as protecting the tubing from damage. In certain situations, multiple controllers with separate solar panels and batteries may be a better solution on sites of a relatively larger area. The optional AC Sipper is designed for locations where line voltage is readily available.

Ease of Deployment

The Solar Sipper can reduce overall project costs and dramatically improve deployment as follows:

- Reduces the time and cost for a power line to be run to a site.
- Eliminates the need for electricians to do install work and permitting.
- The simple and safe low voltage system can be installed without special training or licensing and requires minimal experience.
- No trenching or transformer equipment is required.
- Relocating equipment to follow a plume or to adjust to new site characterization information is fast and easy.

Sipper Operation

The Sipper controller has an integrated programmable cycle timer for controlling the internal compressor vacuum, pressure, and the time between cycles. This allows the user to calibrate the Sipper to run at its most efficient rate based on the down well product recharge rate, product viscosity, and Skimmer depth.

Pumps can be equipped with an H₂O sensor to enhance efficiency and act as a failsafe to protect the system and to avoid pumping water. See the *Sipper Pump and Skimmer Assembly* user manual *Section 3: System Operation* for more information.

During the vacuum timer cycle, vacuum is applied to the airline tubing connected to the stainless steel pump in order to move product through the oleophilic/hydrophobic mesh screen and into the pump cavity.

When the programmed vacuum time expires, the system initiates the pressure timer cycle. During the pressure timer cycle, air is compressed into the air line tubing, evacuating the product from the pump. Once the programmed pressure time has expired, the compressor shuts down and the system initiates the programmed delay timer. Upon expiration of the delay timer, the process is repeated.

On multiple channel Sippers the vacuum, pressure, and delay cycles are set individually per well. This accommodates recharge and recovery rates unique to individual wells on the same site. To maximize efficiency, the Sipper's programming is specifically designed to prioritize which well to pump based on the user defined recharge and recovery rate.

The Sipper controller has several feedback data recording mechanisms that can be used to gauge effectiveness of the remediation system. Two cycle counter screens are available, one records the total lifetime cycles of the controller, the other counter is resettable by the user for monitoring purposes. These cycle counts can be compared with total recovered fluid to determine how much fluid is being recovered per pump cycle. There is also a runtime clock which only increments when the battery is charged and when the system is operating. This clock can be compared with actual recorded deployment time to determine if more solar panels are required to keep the system running. More on this can be found in *Section 6: System Troubleshooting* of this manual.

The Solar Sipper Controller is dependent upon the annual average solar resources, which can vary from region to region. Geotech assists in determining how much potential recovery can be expected depending on where the site is and how many solar panels will be required. More information about solar panel location can be found in *Section 2: System Installation*.

Recovery Rates

The available solar energy and number of solar panels will determine how quickly available product can potentially be recovered. Recovery will ultimately be limited by the recharge rate of the product layer in the well. Repeatedly removing the entire product layer can reduce fluid conductivity to the well and in turn reduce recovery rates overall.

When the product layer is completely depleted, air enters into the well screen and surrounding sub surface soil or strata. This air can act to block fluid conductivity as well as to promote bacteria growth and breakdown of the product being recovered. This will eventually 'clog' the fluid path to the well and so reduce the product layer recharge rate. Geotech recommends recovering smaller amounts of product more frequently. This will promote continued fluid conductivity to the well. Pumps can be equipped with an H₂O Sensor to act as a failsafe to protect against product layer depletion and minimize water intake. See the *Sipper Pump and Skimmer Assembly* user manual *Section 3: System Operation* for more information.

In the event that the intake screen, discharge line or check valve should get blocked, remove the Skimmer and clean the intake cartridge and connections as described within the "System Maintenance" Section of the *Geotech Sipper Pump and Skimmer Assembly* user manual.

Geotech offers a variety of tools and training to provide you with information on properly maintaining your Sipper system and on obtaining a recharge rate. Contact Geotech to discuss your specific application in detail.

SiteView Telemetry

Geotech's SiteView Telemetry Systems use cellular networks to provide data from remote sites that streamlines the data management process. The use of Geotech's SiteView cloud-based data acquisition and data management software enables the collection, analysis, reporting, and storage of data. SiteView can be accessed from any computer or smartphone with internet connectivity. SiteView manages data from multiple locations reducing the need for localized data management software and data collection hardware.

Antenna

Mounted to the interior of the enclosure is a 915MHz flexible antenna. The antenna provides an omnidirectional patterns allowing for large coverage ranges for installations.

If greater ranges are required, contact Geotech for exterior/remote mount antenna options.

Section 2: System Installation



The standard Geotech Sipper is designed for installation and operation in a non-hazardous, non-classified location with intrinsically safe extension into a hazardous classified location. Geotech does not determine classification of a location. Classification of location is subject to local jurisdiction enforcement of NFPA regulations. All installations should be performed in accordance with NEC.

FPN: NEC 2008 section 500.5 (A) classification of locations says: Through the exercise of ingenuity in the layout of electrical installations for hazardous (classified) locations, it is frequently possible to locate much of the equipment in an unclassified location and, thus, to reduce the amount of special equipment required. FPNs are informational only and are not enforceable as requirements of the NEC.



Sipper installations are to be performed by qualified personnel. If you are not familiar with electrical power equipment, contact a qualified technician to assist you with your installation.

Solar Sipper systems can be modularized and delivered on pallets that can be quickly and easily deployed. This simplifies deployment where existing concrete pads or other infrastructure, does not already exist. Geotech also offers training on proper installation of your Sipper system at its Denver, Colorado manufacturing headquarters.

Installation of the Solar Sipper



AC Sipper Controller - Ensure the main line is turned off at the breaker and that the ON/OFF switch for the control panel is in the OFF position before proceeding with ANY external or internal wiring.

Since the solar array and battery have live voltage, exercise caution when handling either item. Special attention is required to ensure that the correct polarity is known when making connections to the battery and solar panels. Even though the system runs on a safe low voltage, the battery is capable of storing very large amounts of energy from a low impedance source. This can pose a fire and burn hazard.

Avoid shorting out (making contact between both positive and negative terminals) the battery with any tool or bare grounding wire. Leave protective caps in place and only terminate a wire when you have verified it is the correct polarity (positive or negative.) The system can tolerate reverse polarity connections as long as the ON/OFF switch remains in the OFF position.

Solar Panel Location

The annual average solar resources vary from region to region. Geotech assists in determining how much recovery you can expect (depending on where the site is located in the world) and how many solar panels will be required. The site latitude will determine seasonal differences in recovery rate. For example, in the northern hemisphere recovery rates will decline over the winter months and increase during the summer months.

Site-specific information must be considered. Large objects like trees or building structures can block sunlight from the reaching the solar panels. To maximize sun exposure, other unpredictable factors,

such as more or less cloud cover, must be also be considered when planning solar power capacity requirements.

Geotech offers two different solar panel mounts, pole or standalone, to allow for installation in diverse locations.

Pick a location with a maximum exposure to sunlight. Avoid shadows, especially during the middle of the day. Orient the module so that the surface will receive the maximum sun exposure over the year for your particular site. The general guideline for positioning is as follows:

- Solar panels should face south in the northern hemisphere and north in the southern hemisphere.
- A solar panel's angle should be set to the equivalent of your location's latitude; plus 15 degrees during the winter or minus 15 degrees in the summer.

For example, Denver, Colorado's latitude is around 39 degrees. In winter, the panel should be raised to 54 degrees (from 0°) for optimum sun. For permanent installations, setting the panel angle equal to your latitude will suffice.

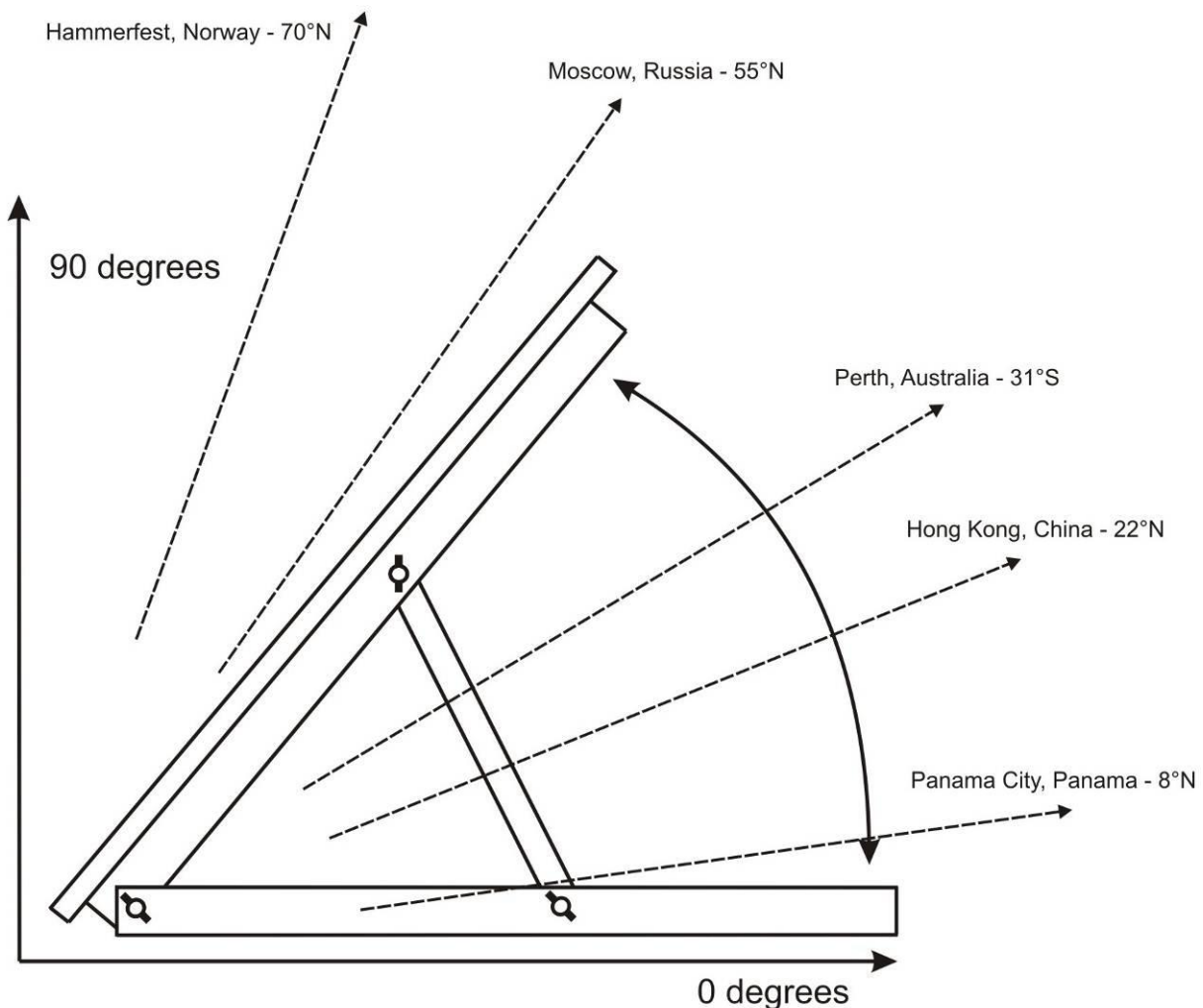

Figure 2-1: Side view of solar panel assembly

Mounting the Control Panel

The enclosure for the Solar Sipper allows the customer the option to place the control panel in a convenient and accessible location. It is recommended the control panel enclosure be placed out of the direct path of weather and sunlight. If line or mains voltage is to be wired to the AC sipper, then all conduit runs are to be rigid metal and grounded to an equipment conductor common for non-current carrying metal parts.

The enclosure needs to be elevated above the height of the wellheads to prevent kinks to the exhaust line and all air lines to the pumps. When selecting a location for your Sipper Controller, consider the placement of air lines to and from the unit to prevent kinks, damage, or the buildup of fluid in sagging lines.

Figure 2-2 is an example of a Sipper control panel mounted to a back panel with 2" (5cm) U-bolts. Using a back panel will support the enclosure while giving you the ability to pole mount the unit.



NEVER drill mounting holes from, or through the inside of the enclosure when attaching the controller to another surface. It is advised that you mount the enclosure to a strong back panel, using the brackets supplied, before attaching the unit to a pole or other surface.

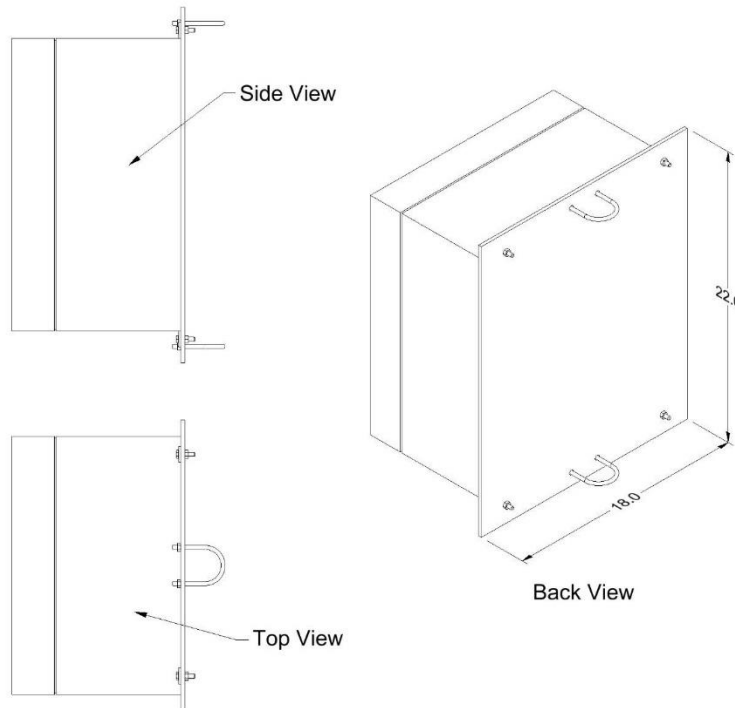

Figure 2-2: Example of Sipper enclosure mounted to back panel with additional U-bolts for pole attachment.



Diagram is an example only. Mounting hardware shown is available through Geotech. See *Section 9: Parts and Accessories*. Always avoid drilling through the enclosure body.

Solar Sipper Wiring



Operational flow charts are affixed to the inside door of each controller. Refer to *Section 8: System Schematics*.



Before installing the solar panel for the Solar Sipper controller, cover the array with an opaque material before making your wiring connections. This will prevent the modules from producing electricity while making the connections and reduce the risk of sparks. Use safe electrical practices at all times. Make connections in well-ventilated areas free from flammable gas vapors and open flames.

Solar Sipper systems are supplied with 25' (7.6 m) of 4 conductors 14 AWG cable. DO NOT modify the length of this power cable. After ensuring the power switch on the controller is set to OFF, make all external power connections as shown in Figure 2-3.

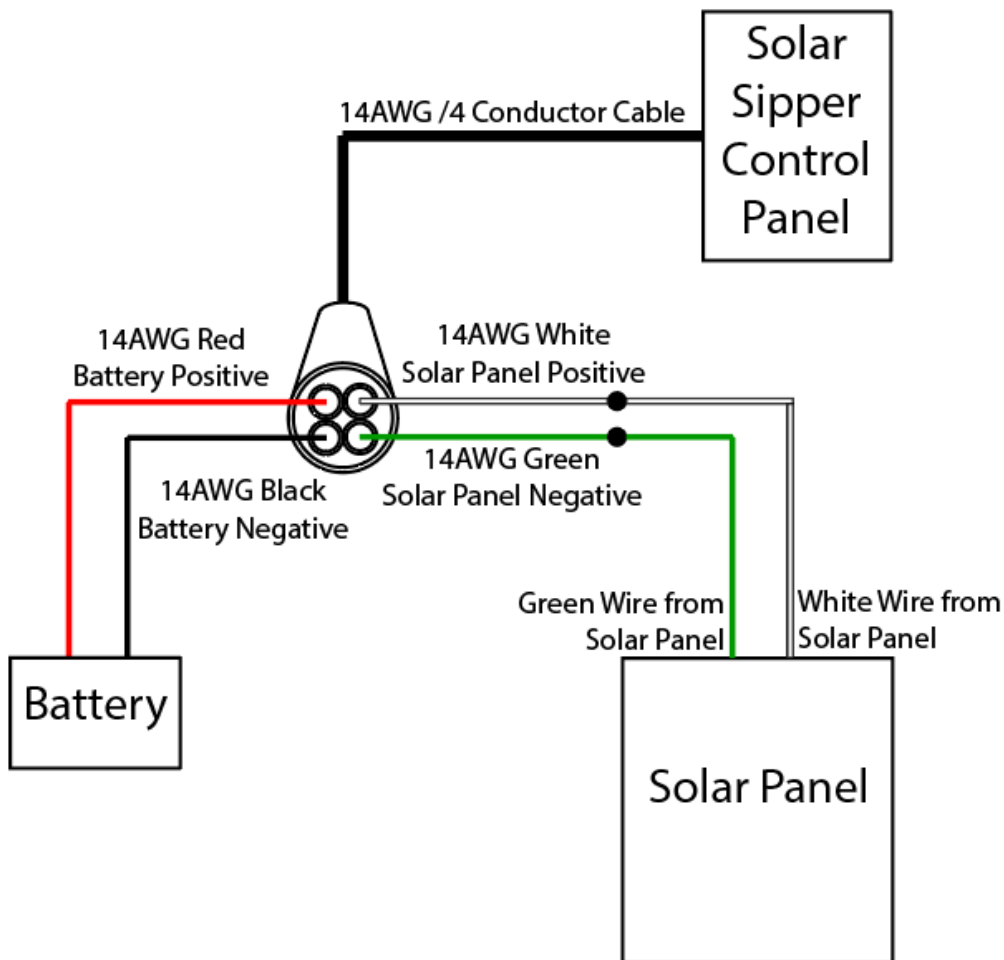

Figure 2-3: Example of external wiring for a Solar Sipper system.



A new or replacement battery may not be fully charged. This will cause the Solar Sipper to go into low voltage shutdown when initially powered up. Allowing the battery to fully charge before deployment will accelerate initial startup. Otherwise, the system could take several days to begin operating depending on the number of solar panels used and the amount of sun exposure. If freeze conditions exist, insulate your battery. Do not use a battery that is frozen or has been frozen. See *Section 3: Timer/Cycle Settings and Display Descriptions* for minimum voltage requirements.

Adding Additional Panels

During the winter months when the sunlight decreases, additional solar panels can easily be added to the Solar Sipper system. Additional panels will ensure production during the winter months when there are fewer hours of sunlight and the excess energy will not be used in the summer. As a general guideline, up to four (4) 80W panels may be connected to the Solar Sipper System.

To wire an additional solar panel to the system configuration, use the wiring diagram shown in Figure 2-3. Using insulated wire nuts, connect all red wires (positive) from the solar panel(s) to the white wire on the Sipper controller, then connect all black wires (negative) from the solar panel to the green wire on the Sipper controller.

Adding Additional Batteries

Additional batteries may be added, in parallel, to increase runtime without sunlight. Additional batteries will require additional solar panels to charge, while sunlight is available. Adding additional batteries without additional solar panels, will reduce the performance of the system.

AC Sipper Wiring

AC Sipper systems are supplied with 25' (7.6 m) of 3 conductors 12 AWG cable. DO NOT extend or add to the length of this power cord. After ensuring that the power switch is set to OFF, make the power connections using Figure 2-4 below:

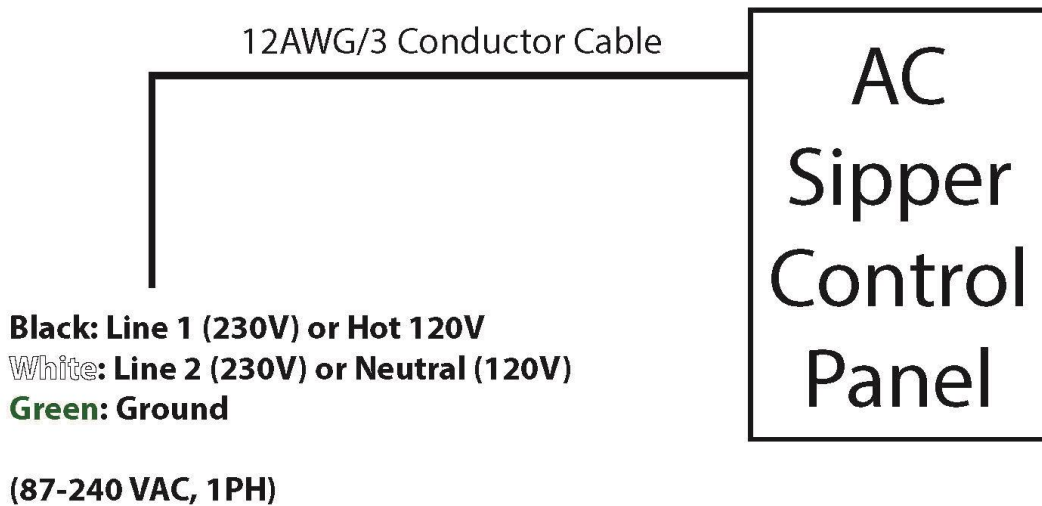

Figure 2-4: Example of external wiring for an AC Sipper system.



Dangerous shock and fire hazard will exist with any line/mains voltage wiring termination. Sipper installations are to be performed by qualified personnel. If you are not familiar with electrical power equipment, contact a qualified electrician to assist you with your installation.

Always verify that live voltage is not present at terminals to be worked on. Shut off all circuit breakers and disconnects, then use a voltmeter or voltage detector to verify power has been removed. Verify the meter is functional by turning the power on and off once or twice before proceeding. Only proceed wiring to AC power terminals when you are certain it is safe.

Grounding

If no earth ground terminal is available, then a ground spike must be installed. Connect all non-current carrying metal parts to the common ground. An earth ground terminal can be purchased from Geotech with your Sipper. See *Section 9: Parts and Accessories* for a complete listing of available accessories.

Connect All Tubing Runs

The Sipper is equipped with brass hose barb fittings that accept .170" ID Tubing, for the Air In/Exhaust, and Pump connections. If a different size hose barb is needed, the factory installed hose barbs can be removed and ¼" NPTM fitting can be used to accommodate different fittings. See *Section 7: System Specifications*.

Lay out all tubing lengths to the wellheads and secure the ends to the hose barbs using environmentally rated clamps. Geotech can supply your Sipper system with a variety of tubing and clamp choices. See *Section 9: Parts and Accessories* for a list of available parts.

When installing tubing runs, consider the placement of air lines to and from the unit to prevent kinks, damage, or the buildup of fluid in sagging lines. Keep all air lines flat and straight, and avoid sharp bends, which can kink your line.

It is recommended that air lines and hoses be protected. However, check local and state regulations regarding fuel transmission lines before installing the product discharge lines.



If there is a chance the Sipper system will be exposed to freezing conditions (see temperature range in *Section 7: System Specifications*), then it is suggested all discharge lines, including the battery, be insulated or your system be kept within a temperature controlled shelter during operation.

The last line connected will be from the compressor air intake and exhaust port, on the side of the Sipper controller, to the top of the recovery tank. The Sipper controller will use this line as an air source and as a failsafe should product be vacuumed into the compressor and solenoids.

Deploy the Stainless Steel Pump and Skimmer



Read user manual *Geotech Pump and Skimmer Assembly* (P/N 16550181) for more information on Skimmers, their parts, and functions.

The oleophilic/hydrophobic mesh screen discriminates between water and product when it is properly "conditioned". To condition (or prime) a cartridge, use a soft brush and coat the mesh screen with the same or a like product found in the well. DO NOT use baby oil, lamp oil or other similar dyed, perfumed or hydrogenated oils.



Do not damage the float or screened intake before or during deployment. Use a scrap piece of plywood or cardboard (something that can be properly disposed of if contaminated) on which to set the pump and Skimmer assembly on instead of the ground.

Good site characterization is important for successfully placing the pump and Skimmer assembly at the optimal level in the well. If seasonal or tidal fluctuations in the groundwater table exceed the travel of the Skimmer, periodic manual adjustment may be required. Otherwise, and in most cases, the Skimmer

should be placed such that its center of travel is at the nominal ground water level (refer to Figure 8-1 and 8-2.) If the groundwater table level is unknown, Geotech can provide you with an oil/water interface probe to determine the current water level and product layer thickness. Contact Geotech for more information on this important device for site characterization.

Using a separate measuring tape, measure from the middle of the center rod on the Skimmer (also the center of vertical travel of the Skimmer intake float) to where the discharge tubing will exit the well cap. Using contrasting tape or chalk, mark the discharge tubing at this point. The lower end of the Skimmer assembly will displace fluid in the well causing the fluid level to rise initially. The float travel will accommodate this rise in fluid level. The fluid level will take some time to return to normal depending on permeability/hydraulic conductivity of the formation surrounding the well.



Read user manual *Geotech Pump and Skimmer Assembly* (P/N 16550181) for more information on Skimmer operation, float travel, and other dimensions.

In some cases, the initial displacement of fluid can ‘displace’ the product layer from the well and back into the formation. This can happen especially where there is low fluid conductivity surrounding the well. It is best to trust the site characterization data and test with a Geotech oil/water interface probe to verify that the float is at the expected level within the well. If you cannot access an oil/water interface probe, or are deploying pumps in a 2” (5 cm) well without enough clearance for the probe, you can judge productivity by how much product is in the recovery tank.



For accurate results, measure well to determine the best placement for the Skimmer. Use a Geotech oil/water interface probe to measure water level and product layer thickness, then record this information to your remediation/characterization log.

Implementing the use of a Geotech oil/water interface probe and keeping a record of the water level and product layer thickness is recommended for maintaining optimal system performance.

Product Recovery Tank

A product recovery tank is not provided with the Solar Sipper system. A tank, preferably a 55 gallon (208 L) drum or larger, must be provided by the customer with the following attributes:

- A 3/4” (2 cm) or 2” (5 cm) threaded bung opening in which the Tankfull probe will be attached.
- A product inlet opening for the system discharge hose.
- A vent opening.
- A fluid discharge fitting for draining.

A Tankfull probe, shown in Figure 2-5, is provided with new Solar Sipper systems. Additional Tankfull probes can be ordered and utilized with the controller. See *Section 9: Parts and Accessories*.



Ensure that the compressor air intake and exhaust air line is secured to the top of the recovery tank prior to turning on the Sipper controller. Do not allow the end of this tubing to reach the product already collected.

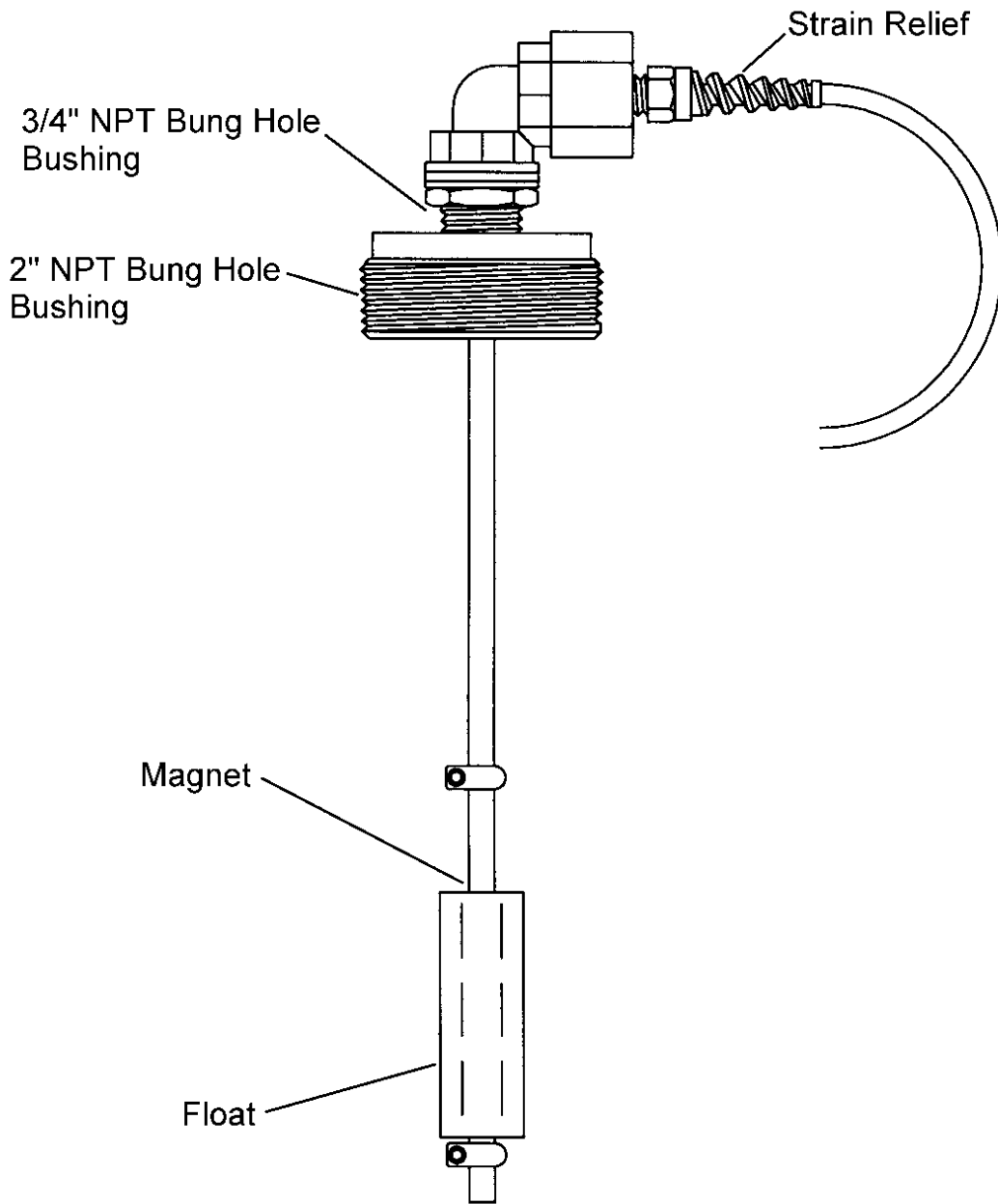

Figure 2-5: Example of Tankfull Probe

Installation Guide: Desiccant Dryer Kit for Geotech Sipper (Solar or AC)

If operating in humid environments, it is recommended to install a desiccant dryer kit with the Geotech Sipper (Solar or AC) to minimize the amount of moisturized air that enters the pneumatic system. This will minimize solenoid maintenance and optimize compressor performance.

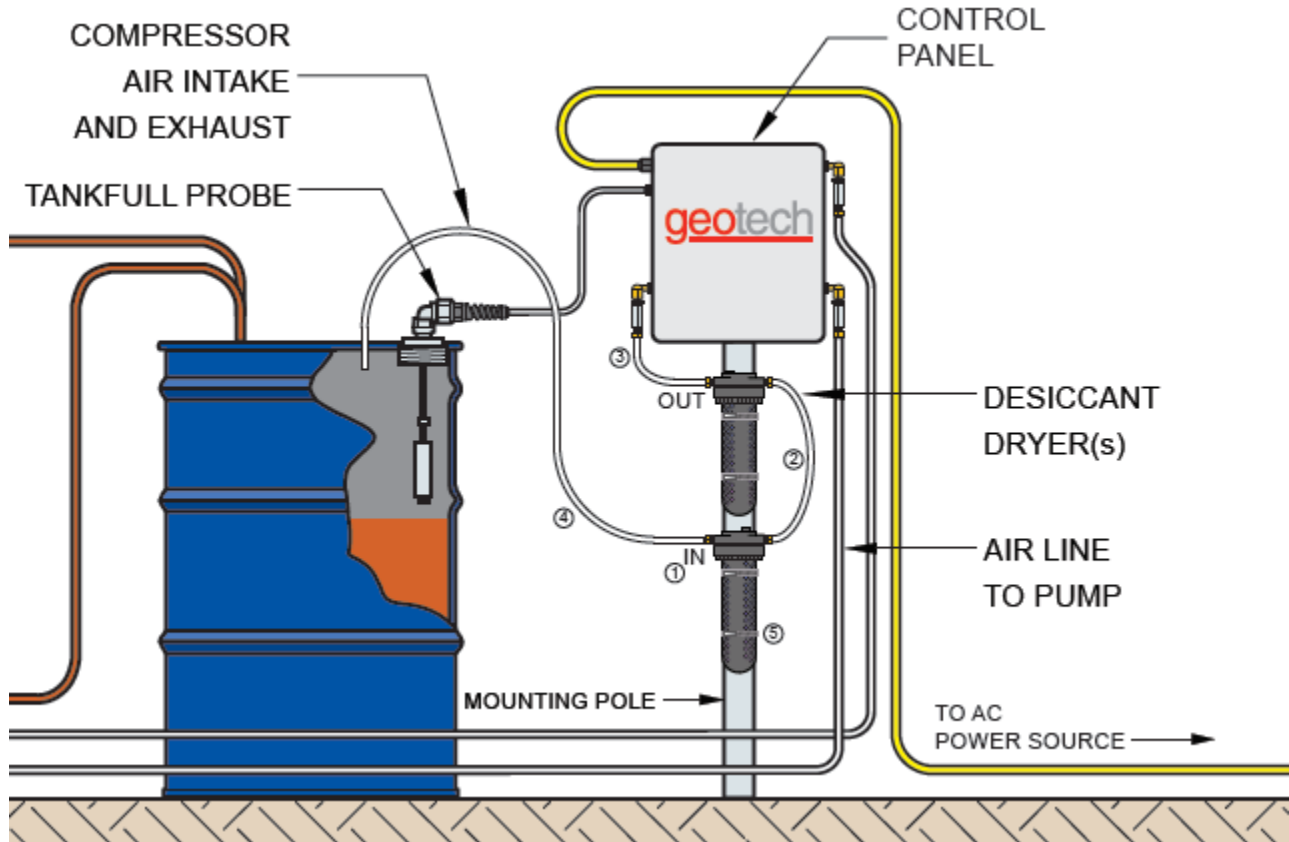

Figure 2-6: System Set-up with Desiccant Dryer Kit

Install the desiccant dryers on the Compressor Air Intake and Exhaust line:

1. Locate the "IN" and "OUT" ports on the dryers.
2. Stack the two dryer's together by connecting an "OUT" port on one dryer to an "IN" port on the other dryer using .17" (4mm) ID tubing.
3. Connect the remaining "OUT" port to the Intake/Exhaust fitting on the Sipper Enclosure using .17" (4mm) ID tubing.
4. Connect the .17" (4mm) ID tubing to the remaining "IN" port on the dryer. The end of this tubing will terminate to the recovery tank (position above tankfull probe), or to where site requirements permit.
5. Mount the desiccant dryers to a pole using the provided worm-drive clamps. Desiccant dryers should remain vertical for optimal moisture recovery.

The Desiccant Dryer's silicone beads will change from blue to pink as the dryer is saturated. Replace desiccant as necessary.

Desiccant Maintenance

When the desiccant has turned from blue (dry) to pink (wet)

- 1) Turn off unit.
- 2) Remove the quick disconnect coupling for air.
- 3) Remove the top cap.

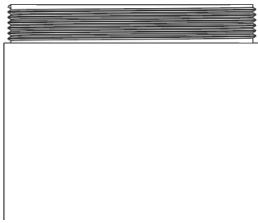

Desiccant Replacement

- 1) Pour out used desiccant.
- 2) Open new desiccant container and fill bowl.

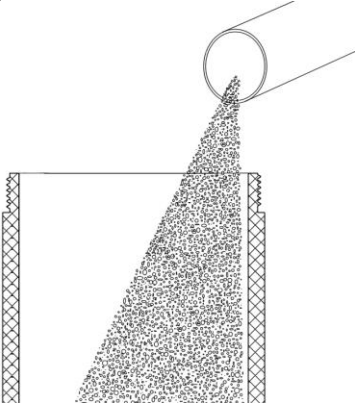

- 3) Shake or tap bowl to settle the desiccant.
- 4) Fill bowl to 1/8" (3.175 mm) below the top.

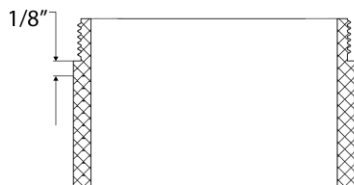

- 5) Replace the top cap.
- 6) Ensure the top cap is tightened securely before re-pressurizing unit.
- 7) Connect the quick disconnect coupling for air.

Section 3: Timer/Cycle Settings and Display Descriptions

This section describes the display functions and the operation of the Sipper controller. Each controller comes with a User Interface Flowchart (shown in Figure 3-2) inside the enclosure lid. The flowchart, used in conjunction with the arrow buttons on the control panel (shown in Figure 3-3) is designed to provide the following operator functions:

- Setting the cycle time (vacuum, pressure, and delay) for each pump and Skimmer assembly.
- Initiating the run time for Sipper system.
- Accessing system status and diagnostic displays.

The following pages show examples of all controller displays and a brief description of their function. Contact Geotech for any assistance in operating your Sipper controller.

Setup Displays

Once the Sipper system has been installed and all wiring to the controller is complete, turn on the main power switch to the Sipper controller. The unit will perform a quick internal self-check and memory configuration, after which the Main Menu will appear on the display as follows:

```
Geotech Sipper  
L=Setup R=Start
```

If the internal self-check fails then the screen will display the appropriate alarm condition. See *Alarm (condition)* and *Fault Displays* later in this section.

First, set your timer/cycle settings using the Setup displays. The Setup displays allow you to select each pump individually and assign a unique cycle time (vacuum, pressure, and delay) for the pump based on the performance of the well it resides. (See *Section 4: System Operation* for more information on evaluating the appropriate cycle time.) The cycle time range for each function is as follows:

Vacuum (<i>the duration of the vacuum cycle</i>)	0 second minimum to a 3 minute maximum.
Pressure (<i>the duration of the pressure cycle</i>)	0 second minimum to a 4 minute maximum.
Delay (<i>minimum time between cycles</i>)	30 second minimum to a maximum of 24 hours.



Factory default for all timer settings, for each pump installed, are 1 second of vacuum, 30 seconds of pressure, 5 minutes of delay.

Set timers based on site requirements.

The system will only operate one well at a time.

If the total vacuum time and pressure time of all the wells is longer than the delay of any one well, then the time between cycles will be longer than what the delay timer has been set to. The display of the delayed well(s) will show a negative value.

Cycle priority will always be given to the well that has been delayed the longest (i.e., the well with the most negative value). See *Section 4: System Operation: Cycle Priority* for an example.

Set up Display

To access the Setup displays, press the left arrow button. The following display will appear:

```
Select Well  
n L=Main Menu
```

Where n = the well number

Using the UP and DOWN arrow buttons, select the well number for which cycle time you wish to set (the number of wells per Sipper controller can be between 1 and 7, depending on the configuration.) After selecting a well number, press the RIGHT arrow. The Vacuum display will appear:

```
Set Vacuum mm:ss  
00:01
```

Using the UP and DOWN arrow buttons, scroll to the time required for the vacuum phase of the cycle, and then press the RIGHT arrow button. The Pressure display will appear:

```
Set Pres mm:ss  
00:30
```

Using the UP and DOWN arrow buttons, scroll to the time required for the pressure phase of the cycle, and then press the RIGHT arrow button. The Delay display will appear:

```
Set Del hh:mm:ss  
00:05:00
```

Using the UP and DOWN arrow buttons, scroll to the time required for the delay time of the cycle, then press the RIGHT arrow button one more time. The system will return you to the Select Well display from which you can set the cycle time for any remaining wells.



If the LEFT arrow button is pressed at any time while setting the vacuum, pressure, and delay times, the new or adjusted setting entered will not be retained. To lock in the cycle time entered, press the RIGHT arrow button.

After all cycle times have been entered, press the left arrow button (while on the Select Well display) to return to the Main Menu.

Start (Runtime) Displays

The Start (Runtime) displays allow you to:

- Reset the cycle count and runtime (see also “Runtime” display under System Status).
- Turn ON/OFF the low temperature shutoff.
- Set the well number to start pumping.
- Start and activate the preset cycle times for all the pumps attached.

Once the Sipper has been started (Runtime activated for all pumps), you can do one of two things:

- Press the DOWN arrow button (to review and page through the System Status displays).
- Press the LEFT arrow button (which will complete the current pump’s cycle time, then return you to the Main Menu).

To start the Solar Sipper and activate the runtime to all pumps attached, proceed as follows:

From the Main Menu, press the RIGHT arrow button. The following display will appear:

```
Reset Timer?  
  YES
```

The Reset Timer display allows you to clear the cycle count and runtime shown in both the system Runtime and the Status Runtime displays. Use the UP and DOWN arrow buttons to change this setting to YES or NO then press the RIGHT arrow button for the next screen.

```
Low Temp ShutOff  
  OFF
```

The Low Temp Shutoff display (when enabled), will shut down the Sipper controller at 0°C (32°F). Since the Sipper system primarily operates above ground, this feature prevents the controller from operating during a time when product lines could freeze. The Sipper will automatically restart at a temperature of 3.3°C (38°F). Use the UP and DOWN arrow buttons to change this setting to ON or OFF.

```
Start with Well  
  n
```

Where n = the number of well (between 1 and 7).

The Start with Well display allows the user to choose the well to pump first upon startup. The well number selection is limited by the number of channels in use. Use the UP and DOWN arrow buttons to change the well number to start with.



The Sipper system is now ready for startup (Runtime). However, before proceeding, thoroughly read *Section 4: System Operation* to better understand the required timer adjustments needed for the product being recovered.

Once all cycle times have been entered and the previous three screens have been entered, press the RIGHT arrow button one more time to start the Sipper. The Sipper controller will begin cycling the first pump in the series and give you the following Runtime display:

```
00:00:00      nn  
0000:00:00:00 wf
```

Where nn = the total number of cycles since activation (1 to 99999)
w = the well number currently activated
f = the pump function currently in progress (V for vacuum, P for pressure, D for Delay)

After verifying all pumps are running, you can re-verify the System Status at any time by pressing the DOWN arrow button during operation. After viewing the status displays, leave the last display as is and the system will automatically return to the Runtime display.

When a well has an active condition (pump conductivity, IR override, tankfull), the main screen will change to

```
00:00:00      WF
WELL:  12_*____7
```

Where 00:00:00 = the remaining timer for the current operation
W = the well number currently activated
f = the pump function currently in progress (V for vacuum, P for pressure, D for delay)
= the well has an active condition (pump conductivity, IR override, tankfull...etc.)
_ = the well does not have an active condition
* = the well is not enabled

If all wells have an active condition, preventing the system from running any operations, the top line of the display will change from showing the remaining cycle time to showing.

```
NO WELLS READY
WELL:  1234567
```

When SiteView is updating the configuration and settings of the Sipper, the following screen will be shown on the display:

```
Please Wait
Settings Update
```

While this display is shown, the operator is prevented from changing the operation mode of the device, or from entering new device settings. This ensures consistency with settings between a local operator, and a SiteView user updating settings remotely.

If a settings update occurs while the system is running, the current run cycle is completed and the device is held in the delay state until the settings are fully updated.

Stopping Sipper Operation (Runtime)

If further adjustments are needed to the cycle time of a particular pump or when the Sipper controller needs to be shut down, press the LEFT arrow button once during the Runtime mode. If the Sipper is currently in the middle of a pump's cycle time, it will give you the following display:

```
Please wait for
Main Menu mm:ss
```

This display will show how much time is left with the current well. Once the pressure phase of the cycle completes, the unit will stop all processes and display the Main Menu. Further adjustments can then be made to the pump cycle times, information retrieved from the Status Displays, or the unit can be turned off for service.

System Status and Diagnostic Displays



The value "nn" within this section can represent a count anywhere from 1 to 999999.

For fault displays, the value "000000:00:00:00" will reflect the real-time Clock (yymmdd hh:mm:ss) if the system includes access to the SiteView. If the system does not include access to SiteView, the value 0000:00:00:00 will reference the system Lifetime (dddd:hh:mm:ss). The Lifetime display will not indicate any specific events. Event time will need to be manually calculated.

While at the Main Menu, system Status Displays can be viewed by pressing the UP and DOWN arrow buttons. These displays contain a variety of information that can be used to record important activity to your Sipper system. These displays can also be viewed during the system's Runtime by pressing the UP or DOWN arrow buttons at any time during operation. After viewing a status display, leave the system as is. Within 1 minute, the Main Menu (or Runtime display) will reappear.

The following status displays (as shown on the Interface Flowchart, Figure 3-2) will appear with each press of the DOWN arrow button. The following pages will show you an example of each status display (as they appear) followed by a definition and use of the display.

```
Runtime: nn  
0000:00:00:00
```

The Runtime display shows the number of completed cycles (for all pumps attached) along with the total runtime of the Sipper system since the controller was last reset. These values can be cleared with the Reset Timer display during initial startup.

```
Lifetime: nn  
0000:00:00:00
```

The Lifetime display shows the total number of completed cycles (for all pumps attached) along with the total runtime of the Sipper system since the unit was first put into service. Lifetime values cannot be cleared. Many of the status displays will retrieve their time stamps from this display when something occurs, such as the last time there was a low battery, the last time a tankfull alarm was activated, the last time a low temp shutoff occurred, etc.

```
Power On: nn  
0000:00:00:00
```

The Power On display shows the total number of times the unit has been powered ON/OFF (since being put into service, including factory testing) along with a time record of when the unit was last powered on.

```
Enabled Wells:  
* * * * *
```

Where * = Well is not enabled.

The Enabled Wells display shows the total number of wells included with the system.

To change enabled/disabled wells, the user will need to go through the startup process (see Figure 3-2, Start note 2). Pressing the UP arrow will enable the well and the asterisk will change to the well number that has been enabled. There can be up to 7 wells per device.

```
Fluid Override:  
* * * * *
```

Where * = Well is not detecting fluid.

The Fluid Override display shows which well(s) fluid is detected in. A warning is triggered in SiteView.

```
Fluid In Pump  
* * * *
```

Where * = Pump is not detecting water.

The Fluid In Pump screen displays which pump is detecting water if a conductivity probe is being used in any well.

Well nn Delay:
hh:mm:ss

The Well Delay display shows how much delay time is left for each well assigned to the Sipper. Use the DOWN arrow button to page through all seven (7) displays. Channels not in use will have a display value of 0.

If more than one pump reaches the delay expiration (the delay countdown time reaches 0), the delay time will track a negative value. The well with the most negative value will be the next well to run.

Comp: nnn
0000:00:00:00

The Comp display shows how many times the compressor has powered ON/OFF (since being put into service, including factory testing) along with the total run time of the compressor.

AUX Input:nnnnnn
0000:00:00:00

The AUX Input display shows how many times the switch has been disconnected for the accessory input devices on the Normally Closed switch (since being put into service, including factory testing) along with a time record of when the switch was last disconnected.

Tankfulls: nn
0000:00:00:00

The Tankfulls display shows the total number of times a tankfull alarm has been activated (since being put into service, including factory testing), due to a full recovery tank(s), along with a time record of when the unit last had a tankfull alarm. This display can be used to determine how long it takes the recovery tank to fill or if a larger tank is required.

Tankfull Status:
* * * * *

Where * = Indicates the recovery tank is not detecting a tankfull alarm.

The Tankfull Status display shows which recovery tank is full.

Low Batts: nn
0000:00:00:00

The Low Batts display shows the total number of times the unit has experienced a low battery condition (since being put into service, including factory testing) along with a time record of when the unit last had a low battery condition. This display can help in evaluating battery usage (in comparison to how much product is being recovered) showing the need for either a cycle adjustment or the need for additional solar panels. It can also help in determining if the battery is losing its ability to maintain a charge.

The Solar Sipper controller is designed to shut itself down when the battery voltage reaches 11.4V and will resume operation when the battery charge reaches 12.1V. The Solar Sipper is designed to charge the battery to a maximum of 14.5V.

If the battery becomes frozen, the screen will be blank; the system will not operate. Discard the battery according to local regulations and connect a new battery.

```
Low Temps: nn  
0000:00:00:00
```

The Low Temps display (when Low Temp Shutoff is enabled during the startup process) shows the total number of times the unit has experienced a low temperature condition (since being put into service, including factory testing) along with a time record of when the unit last had a low temperature condition. A low temperature shutoff (when enabled) will occur at 0°C (32°F).

```
Clock  
yyymmdd hh:mm:ss
```

Where “hh:mm:ss” is displayed in 24-hour clock time. This will be real-time if telemetry is equipped.

```
Intake OR: nn  
0000:00:00:00
```

The Intake OR display shows the total number of times the unit has experienced an Intake Override condition (since being put into service, including factory testing) along with a time record of when the unit last had an Intake Override condition.

```
Temperature:  
nnC nnF xxx
```

The Temperature display shows current temperature of the unit in Celsius and Fahrenheit followed by a diagnostic number.

```
Battery: (STATUS)  
nn.nV xxxx
```

The Battery display shows the current battery voltage for the Sipper system followed by the status. The status will read:

```
    IDLE – Nothing is happening.  
    or  
    BULK – Solar panel is fully connected to the battery.
```

```
Voltage:  
nn.n
```

The Voltage display shows the voltage powering the system. This screen is only used for systems without a solar panel.

```
Well:n  
Version: n.n0nnn
```

The Well/Version display shows the number of wells the system can operate and the software version the system is running.

Radio-nnnn AI=n
ss=nn ■■■■■

- Where nnnn = the last 4 digits of the radio serial number.
- Where ss = signal strength
- Where nn = decibel miliwatts
- Where ■ = signal strength bar graph
- *Good signal strength = 3 bars and up
- *Bad signal strength = 2 bars or less

The Radio display shows the radio information and signal strength.

Order #:
nnnnnn-n

Where -n = is included if more than 1 device is on the order.

The Order # display shows the order number and the number of devices included in the order.

Name :

Shows the name of the system. If the system comes with access to SiteView, the name of the system can be changed on the SiteView website.

Outputs:
Nnnnnnnn

The Outputs display shows the Well Solenoid outputs on PCB board.

HOA
nnnnnnnnnnnnnnnnnn

The HOA display shows the state of the HOA input bank on the PCB.

ISO
nnnnnnnnnnnnnnnnnn

The ISO display shows the intrinsically safe inputs on the PCB board.

ADC <1-3> (val) ADC <4-6> (val) ADC <7-8> (val)
nnn nnn nnn nnn nnn nnn nnn nnn nnn

The ADC display shows the numerical value of the analog inputs.

Alarm (Condition) and Fault Displays

All faults will reference real world clock time when the SiteView is enabled. Systems without SiteView enabled will reference the lifetime counter.

Besides low battery, low temperature, a blown fuse, or no battery connection, only a few other conditions will cause the Sipper controller to shut down. The following display alarms will require attention from the user before the system can be restarted:

AUX Input
L=Main Menu

The AUX Input alarm will appear when an external device with a Normally Closed connection is wired into the PCB and the Normally Closed connection opens.

TANKFULL
L=Main Menu

The TANKFULL display will appear when the recovery tank becomes full or when there is damage to the tankfull probe cable. When this display appears, the Sipper controller will stop all activity until the alarm is addressed. To clear the alarm and restart the Sipper controller, press the LEFT arrow button (to obtain the Main Menu), then initiate the startup process.

INTAKE OVERRIDE
L=Main Menu

The INTAKE OVERRIDE display will appear when the Intake Sensor detects the presence of fluid in the air line, between the compressor and manifold. SiteView will show a Manifold fault. This occurs when:

- An optic sensor failed.
- Product is pulled through the air line from the well due to excessive vacuum time,
- A directional solenoid becomes stuck on the compressor
- There is an accumulation of moisture in the air line during operation.

See *Section 6: System Troubleshooting* for information on resolving an Intake Override alarm.

When the INTAKE OVERRIDE display appears, the Sipper controller will stop all activity until the alarm is addressed. After clearing all effected lines, clear the alarm and restart the Sipper controller by pressing the left arrow button (to access the Main Menu), then initiate the startup process.



You may also need to clear the air line by setting the vacuum to 0 and allowing the pressure cycle to push any residual fluid out of the line and into the pump reservoir. See *Section 6: Troubleshooting*, for more information.

Battery Fault
Check Cables

The Battery Fault display will appear when the voltage on the battery cables is 14.7VDC or greater. This may occur if the solar panel has been miss-wired to the battery input cables. This display will also appear if an overcharged battery has been installed. In any case, when this display is shown, turn the unit off and disconnect all voltage sources immediately. Review Solar Sipper Wiring in *Section 7: System Specifications*. Contact Geotech with any questions on wiring and installation.

PCB Damage

On rare occasions the following display may appear:

System:

The System message will only appear when damage has occurred to the PCB within the Sipper controller. Should this display appear, contact Geotech about the fault. Inform the Geotech Technical Sales Representative of all conditions (weather, temperature, vibration, etc.) and when the fault occurred. A fault message of this kind will usually require the unit be sent to Geotech for diagnostics and repair.

Optional Conductivity Sensor

Pumps can be equipped with an H₂O sensor to enhance efficiency and act as a failsafe to protect the system and to avoid pumping water. See the *Sipper Pump and Skimmer Assembly* user manual *Section 3: System Operation* for more information.

To configure the GECM

Starting with the GECM turned off, press and hold all four Arrow Buttons at the same time and move the ON/OFF switch to the ON position. When the text “ENTERING ADVANCED CONFIG” appears on the LCD screen, release all Arrow Buttons. The first configuration screen is used to reset the well timers to factory default settings. To navigate to the optional conductivity configuration menu, press the UP Arrow button until the screen displays:

```
ENABLE ?  
PUMP H2O DETECT
```

When this screen is displayed, press the RIGHT Arrow Button to enter the configuration menu. The screen will display:

```
PUMP H2O DETECT  
* * * *
```

Where * = Indicates the conductivity probe is not enabled.

Use the RIGHT arrow key to navigate to the well that has a conductivity probe – only the first four wells can utilize a conductivity probe. To enable conductivity for the well, press the UP Arrow button and the display will change from ‘*’ to the well number. If you wish to operate without the conductivity probe, navigate to the desired well and press the DOWN Arrow button.

When finished configuring well conductivity, continue to press the RIGHT Arrow button until the display shows a new configuration menu. From there, repeatedly press the UP Arrow button until the display shows:

```
EXIT ?  
ADVANCED CONFIG
```

Press the RIGHT Arrow button to exit. If you did not make any changes, the display will indicate no changes. If changes were made, the display will show:

```
ADVANCED CONFIG  
SAVE: L=No R=Yes
```

Press the RIGHT Arrow button to save the changes and exit, press the LEFT Arrow button to cancel the changes and exit.

Fault and Tankfull Dry Contact Relay (Equipped on 1-6 Well Systems)

The Sipper is equipped with a dry contact relay which will change state when there is an active fault condition, or any active tankfull alarm. This is useful if there is an external system that is not controlled directly by the Sipper but is part of the process flow and needs to be alerted when there is a fault condition or tankfull alarm. Once energized the dry contact relay will remain latched until the system is reset, or is powered off.

The Fault/Tankfull dry contact relay is connected to a 3-position terminal strip labeled NO (normally open), NC (normally closed), and C (common). It is up to the end user to choose how to wire the common, and if NO or NC is best suited for their application. See Figure 2-1 for example of a standard dry contact configuration.



The Fault/Tankfull dry contact relay does not indicate a power out condition. Power must be supplied to the system for the Fault/Tankfull dry contact relay to switch state when a fault or tankfull condition exists. For a switchable signal based on the system being turned off, a power outage, or not in a running state, please contact Geotech Technical Sales.

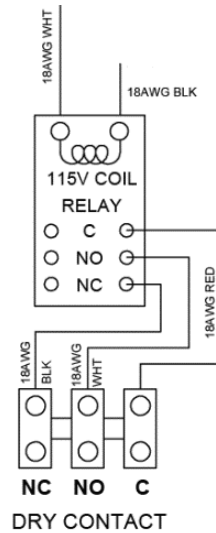

115V Coil Relay: CSA Load Rating

Res.	10A	240VAC
	10A	30VDC
Gen. Use	7.5A	120VAC
	7A	240VAC
	7.5A	30VDC
	1/6HP	120VAC
	1/3HP	240VAC

Figure 3-1: Diagram of Dry Contact

Geotech Sipper User Interface Flow Chart

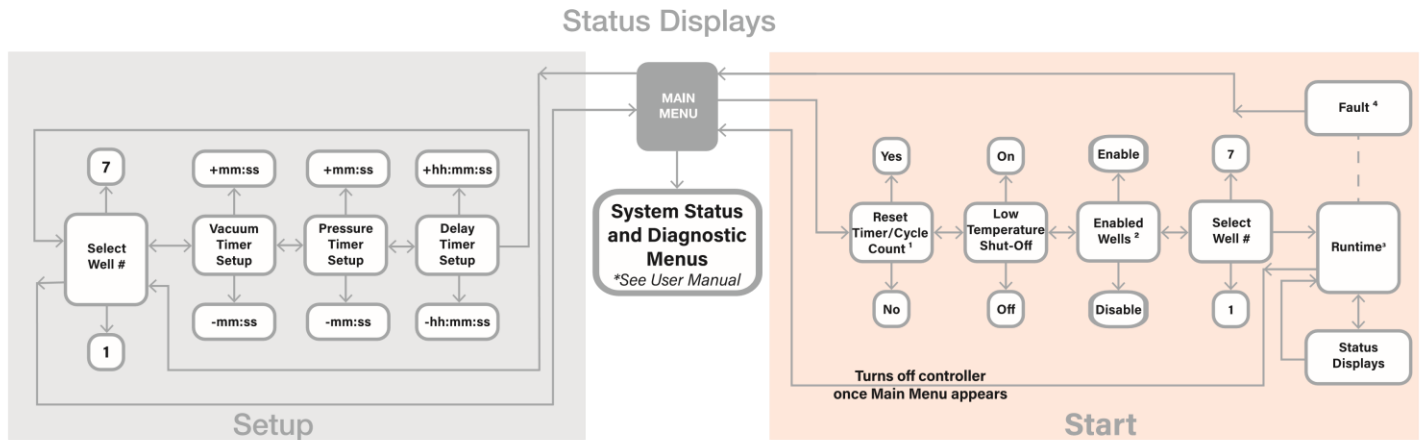

Setup Steps

1. From MAIN MENU, press the left arrow button.
2. Press up or down arrow buttons to select well number.
3. Press the right arrow button to enter vacuum, pressure, and time delay for the selected well #.
4. Press up or down arrow buttons to adjust timer settings.
5. Press the left arrow button to move to Start menu from Select Well menu.

See User Manual for complete user interface description.

Start Notes

1. Both Reset Timer/Cycle Count, Low Temperature Shut-Off, and Enabled Wells need an On/Off, Yes/No, and Enabled/Disabled response, respectively, prior to progressing to the next command.
2. Enable wells by pressing the up arrow. Disable the well by pressing the down arrow.
3. Runtime:

Current Cycle Time → HH:MM:SS nn ← Cycle count
 Total Runtime → DDDD:HH:MM:SS wf ← Well#/Function

If an alarm/condition is detected, "WELL" will show on the display and indicate which well the alarm/condition is detected.

Cycle Time → HH:MM:SS wf ← Well#/Function
 WELL 12_ _ _ 5 6 7 ← Well the alarm is detected in

= Active Condition → *
 _ = No active condition
 * = Not enabled

4. Faults

Press left arrow key to clear faults.

FAULT*
 L=Main Menu

Note:

Status Display may include more information on custom systems. See the user manual for more information.

* See user manual for specific information.



Figure 3-2: Flowchart of User Interface Label



Figure 3-3: Example of Solar Sipper front panel.

Section 4: System Operation



If Sipper system is to be deployed in humid conditions, Geotech recommends installing the optional Desiccant Dryer to prevent frequent solenoid maintenance. See *Section 9: Parts and Accessories* for part information.

Establishing the Product Recovery Cycle Time

The first thing to consider will be a product recovery rate target. The maximum product amount that can be recovered is determined by the recharge rate of each individual well. You can size and adjust your system for optimal recovery rate potential based on the parameters obtained from the well.

The best measure of success is the average measured recovery of fluid in the recovery tank, over a specific time frame, compared to the recovery rate target. Due to seasonal and weather related variability in available solar energy it may be very difficult to schedule site visits to coincide with the system pumping product. If observation of the system in action is desired, schedule a visit in the midafternoon. Otherwise, record your cycle counter value and total run time and compare these with the amount of product recovered.

The vacuum cycle pulls the product into the pump housing. The system compressor will then switch to pressure mode. The compressor is capable of providing up to 100 PSIG (7 bar) (pressure to the pump and the discharge line). The pressure cycle pushes the intake valve shut and forces the product past the discharge valve and up the discharge line to the surface.

It is important that you verify that all product is being pushed out of the pump housing before the next vacuum cycle begins. If the vacuum time interval is set too long, or the pressure cycle set for too short of a period, it is possible for the pump to overfill and for the product to be pulled up the airline and into the Sipper controller. If this happens, set the vacuum time back to 0 seconds and the pressure to 30 seconds and evacuate all the fluid from the float switch housing. After the system is clear of excess fluid, try setting the vacuum time to a lower setting and increase your pressure time to a higher setting for better operation. It is better to start with a higher pressure and lower vacuum setting and adjust over time.

The standard stainless steel pump is capable of holding 0.2 gallons (0.750 mL) of fluid per cycle. That translates into:

- 14" (35 cm) of product layer in a 2" (5 cm) well
- 3.5" (8.9 cm) of product layer in a 4" (10 cm) well

This represents the minimum product layer thickness required to achieve one full pump housing of product per cycle. Even if there is that much product in the well, it is not advisable to pump the product layer all the way down. See Recovery Rates in *Section 1: System Description* for further explanation.

Initiating the Sipper Runtime

Once Runtime has been started, the Solar Sipper system will initiate the vacuum cycle for well number one (or whichever well is selected to start), complete that well's cycle, then continue on through any remaining wells as per the individual user input settings.



The vacuum timer limits are 0 seconds minimum, 30 seconds maximum.

The pressure timer limits are 30 seconds minimum, 4 minutes maximum.

Custom timer settings outside of these min/max parameters can be adjusted through restricted access menus (contact Geotech for more information.) Timer settings outside of the default min/max warrant special consideration to avoid damage to the equipment and otherwise unsatisfactory performance of the system.

The amount of product per cycle will depend on how much product is in the well. In addition, depending on the viscosity of the fluid and temperature, the product layer could have a somewhat slower recharge rate. This can make it difficult to determine what the best cycle times should be for a particular site.

If you have a less than 1 gallon (3.8 L) per hour recharge rate, then simply increase the delay time proportionally. For example: if your product recharge rate is 1/2 gallon (1.9 L) per hour, double the delay time.

- After accounting for more or less recharge rate, you can account for additional tubing and depth to fluid.
- Add 2 seconds per 25' (7.6 m) of tubing for vacuum and 3 seconds per 25' (7.6m) of tubing for pressure.
- Add an additional 2 seconds per 25' (7.6 m) depth to product vacuum (the product only needs to be lifted at most to the top of the pump housing).
- Add an additional 3 seconds per 25' (7.6 m) depth to product pressure to start. You will have to adjust this setting to account to the specific viscosity of the product and the amount of product in the discharge tubing.

It is not necessary to empty the entire length of discharge tubing per cycle. It will be a waste of energy to pump air through the lines when it is not acting to move product. If you observe airflow from the discharge line after the product has stopped flowing, reduce your pressure time by approximately the same amount of time as the extra airflow.

Example: You have a pressure time of 50 seconds; it takes 20 seconds for product to reach the exit end of the discharge tube, product flows for only 20 seconds then air flows freely for 10 seconds. You can reduce your pressure time by 10 seconds. That is an immediate 20 percent reduction in pressure time. This will increase your battery life and, in turn, improve your recovery potential.

Fluid Viscosity



It is impossible to account for the many site-specific variables in this manual. Pump rates for specific applications can only be determined with a careful site analysis.

The following table has been compiled based on lab testing as well as real world Sipper deployments.

If you have a higher recharge rate and require higher production rates than those shown below, please contact Geotech so that we can determine if more solar panels or batteries are necessary.

In some cases, such as in the southwest United States, the standard Solar Sipper can easily outperform the rates shown in the following chart.



The viscosity range shown is based on an average ground water temperature of 50° to 70°F.

Table 4-1: Fluid Viscosity and Sipper Operation (Imperial)

Depth to Fluid in ft	Intake Type	Air Line Length in ft	Product Weight/ Viscosity (SSU) @ 70° F	Product Recharge Rate in GPH	Vacuum Time (mm:ss)	Pressure Time (mm:ss)	Delay Time (hh:mm:ss)
10	100 mesh	25	Gasoline - Light/27.7	1	0:00:15	0:00:30	0:11:00
10	100 mesh	25	Transformer Oil - Light/80	2	0:00:15	0:00:30	0:05:00
10	60 mesh	25	No. 4 Fuel Oil - Medium/170	1	0:00:30	0:01:00	0:11:00
10	60 mesh	25	Hydraulic Oil - Medium/200	2	0:00:30	0:01:00	0:05:00
10	Heavy oil	25	SAE 30 Oil - Heavy/1000	1	0:01:30*	0:03:00*	0:11:00
10	Heavy oil	25	SAE 50 Oil - Heavy/3000	2	0:01:30*	0:03:00*	0:05:00

Table 4-2: Fluid Viscosity and Sipper Operation (Metric)

Depth to Fluid in m	Intake Type	Air Line Length in m	Product Weight/ Viscosity (SSU) @ 21°C	Product Recharge Rate in LPH	Vacuum Time (mm:ss)	Pressure Time (mm:ss)	Delay Time (hh:mm:ss)
0.3	100 mesh	7.6	Gasoline - Light/27.7	3.78	0:00:15	0:00:30	0:11:00
0.3	100 mesh	7.6	Transformer Oil - Light/80	7.5	0:00:15	0:00:30	0:05:00
0.3	60 mesh	7.6	No. 4 Fuel Oil - Medium/170	3.78	0:00:30	0:01:00	0:11:00
0.3	60 mesh	7.6	Hydraulic Oil - Medium/200	7.5	0:00:30	0:01:00	0:05:00
0.3	Heavy oil	7.6	SAE 30 Oil - Heavy/1000	3.78	0:01:30*	0:03:00*	0:11:00
0.3	Heavy oil	7.6	SAE 50 Oil - Heavy/3000	7.5	0:01:30*	0:03:00*	0:05:00

**Contact Geotech for instructions on how to enable timer settings beyond the standard limits. The standard limits are in place to protect against accidentally setting vacuum or pressure times that could reduce system up time and potentially damage the equipment.*

**The standard stainless steel pump is capable of holding 0.2 gallons (0.750 mL) of fluid per cycle.*

**In perfect conditions, you could recover 55 gallons of product per day. That is 0.2 gallons per cycle per minute for 4.6 hours in one well.*

Recovery Tank is Full

When the tankfull probe detects a full recovery tank, the Sipper will complete the current cycle before shutting the Sipper controller off. The following message will appear:

```
TANKFULL
L=Main Menu
```

During this time, the unit will continue to charge the battery, and if enabled, monitor the temperature. Once the recovery tank is emptied, press the left arrow button for the Main Menu and restart the unit as described in the beginning of *Section 3: Time/Cycle Settings and Display Descriptions*.

Cycle Priority

The Example below is for a 3 Well unit with the following settings:

- Well #1: Vacuum, 1 second; Pressure, 30 seconds; Delay, 50 minutes.
- Well #2: Vacuum, 1 second; Pressure, 30 seconds; Delay, 1 minute.
- Well #3: Vacuum, 3 minutes; Pressure, 4 minutes; Delay, 5 minutes.

On the initial startup of the unit the cycles occur in ascending numeric order. The **highlight** indicates the state of operation for the given phase.

1	Well #1	Vacuum: 00:01	The unit will cycle well #1 vacuum cycle for 1 second.
		Pressure: 00:30	
		Delay: 50:00	
	Well #2	Vacuum: 00:01	Waiting
		Pressure: 00:30	
		Delay: 01:00	
	Well #3	Vacuum: 03:00	Waiting
		Pressure: 04:00	
		Delay: 05:00	

2	Well #1	Vacuum: 00:01	<ul style="list-style-type: none"> • The value resets to 1 second • Unit will now cycle Well #1 pressure cycle for 30 seconds.
		Pressure: 00:30	
		Delay: 50:00	
	Well #2	Vacuum: 00:01	Waiting
		Pressure: 00:30	
		Delay: 01:00	
	Well #3	Vacuum: 03:00	Waiting
		Pressure: 04:00	
		Delay: 05:00	

3	Well #1	Vacuum: 00:01	Delay time will keep decreasing.
		Pressure: 00:30	
		Delay: 50:00	
	Well #2	Vacuum: 00:01	<ul style="list-style-type: none"> • Vacuum resets to 1 second • Unit will now cycle well #2 pressure cycle for 30 seconds.
		Pressure: 00:30	
		Delay: 01:00	
	Well #3	Vacuum: 03:00	Waiting
		Pressure: 04:00	
		Delay: 05:00	

4	Well #1	Vacuum: 00:01	Delay time will keep decreasing.
		Pressure: 00:30	
		Delay: 49:59	
4	Well #2	Vacuum: 00:01	<ul style="list-style-type: none"> • Vacuum resets to 1 second • Unit will now cycle well #2 pressure cycle for 30 seconds.
		Pressure: 00:30	
		Delay: 01:00	
4	Well #3	Vacuum: 03:00	Waiting
		Pressure: 04:00	
		Delay: 05:00	

5	Well #1	Vacuum: 00:01	Delay cycle keeps decreasing
		Pressure: 00:30	
		Delay: 49:29	
5	Well #2	Vacuum: 00:01	<ul style="list-style-type: none"> • Pressure value resets to 30 seconds. • Well #2 delay time starts once well #2 pressure cycle ends.
		Pressure: 00:30	
		Delay: 01:00	
5	Well #3	Vacuum: 03:00	The unit will now cycle well #3 vacuum cycle for 3 minutes.
		Pressure: 04:00	
		Delay: 05:00	

6	Well #1	Vacuum: 00:01	Delay cycle keeps decreasing
		Pressure: 00:30	
		Delay: 46:29	
6	Well #2	Vacuum: 00:01	Delay cycle has reached "0" and is now keeping track of negative time.
		Pressure: 00:30	
		Delay: -02:00	
6	Well #3	Vacuum: 03:00	Well #3 pressure cycle starts.
		Pressure: 04:00	
		Delay: 05:00	

7	Well #1	Vacuum: 00:01	Delay cycle keeps decreasing
		Pressure: 00:30	
		Delay: 42:29	
7	Well #2	Vacuum: 00:01	<ul style="list-style-type: none"> • Since well #2 has the smallest delay timer value, this well is the next well to cycle. • Well #2 vacuum cycles starts.
		Pressure: 00:30	
		Delay: 01:00	
7	Well #3	Vacuum: 03:00	<ul style="list-style-type: none"> • Pressure value resets to 4 minutes. • Delay timer begins to decrease.
		Pressure: 04:00	
		Delay: 05:00	

8	Well #1	Vacuum: 00:01	Delay cycle keeps decreasing
		Pressure: 00:30	
		Delay: 42:28	
8	Well #2	Vacuum: 00:01	<ul style="list-style-type: none"> • Vacuum resets to 1 second. • Pressure cycles cycle starts.
		Pressure: 00:30	
		Delay: 01:00	
8	Well #3	Vacuum: 03:00	Delay cycle keeps decreasing
		Pressure: 04:00	
		Delay: 4:59	

9

Well #1	Vacuum: 00:01	Delay cycle keeps decreasing
	Pressure: 00:30	
	Delay: 41:58	
Well #2	Vacuum: 00:01	<ul style="list-style-type: none">• Pressure resets to 30 seconds.• Delay starts to decrease.
	Pressure: 00:30	
	Delay: 01:00	
Well #3	Vacuum: 03:00	Delay cycle keeps decreasing
	Pressure: 04:00	
	Delay: 4:29	

Since all delay timers have a positive value, the unit will stay off until a Delay time reaches 0:00 and will begin running that wells cycle.

The timer closest to "0" will show on the display.

Section 5: System Maintenance



Sipper controllers must be returned to Geotech for internal repairs or service.

Sipper Controller

Weekly Maintenance

- Record the level of the recovery tank (depending on the recovery rate).
- Visually inspect all air lines and power cords for damage.

Monthly Maintenance

- Rinse debris off the solar panel with clean water – DO NOT use anything abrasive on the panel surface. Clean the front surface of the solar panel and controller enclosure as needed with mild soap and water and a soft cloth.
- Inspect the product pump and Skimmer. Visually inspect the Skimmer, making sure that the coiled hose is not tangled, and that the intake assembly moves freely over its travel range.
- Visually inspect the vent plugs in the bottom of the controller enclosure. Clean if obstructed with debris.
- Record the uptime counter from the Lifetime display monthly during the first year. This information can be used to schedule yearly maintenance for the least productive times of the year (due to local variations in the weather and solar exposure).
- Record the level of the recovery tank (depending on the recovery rate).
- Check to see if wildlife (insects, birds, mice, etc.) have not taken up residence in the controller or battery enclosures. Nests and debris can result in vent plug blockage in the battery box, allowing hazardous and explosive gas to build up. Build-up on the controls can result in overheating the electronics and possible failure of components.
- Verify fluid levels in the well using a Geotech Interface Probe. Make sure the pump and Skimmer are set at the correct interval for collection of product.
- Verify pump vacuum, pressure, and delay settings. Make sure the cycling rate of the system is correct for the amount of product available. If the well is slow to recharge and/or there is only a small volume of product to pump, the pumping rate should be decreased to conserve air and minimize controller and battery wear. Consult Geotech Technical Sales and this User Manual for guidance on how to properly set these times. DO NOT adjust if unsure.
- If using the optional Desiccant Dryer for the Sipper system, check the saturation of the desiccant packs and replace packs if necessary.

Quarterly Maintenance

- Verify fluid (or air flow if no product in the well) is being discharged into the recovery tank to ensure pump check valves and tubing are free from blockage and that the discharge hose is not kinked or cut.
- Verify that the Tankfull float moves freely and operates to shut off the Sipper controller when activated.
- Verify Intake Sensor Switch detects fluid.
- Inspect the exterior of the controller for loose fittings. Over time, vibration may cause some fittings to loosen and air leaks to develop. If uncorrected, excess air consumption and shortened controller life will result.

- Verify that your solar panel is correctly positioned for maximum sunlight. Panels can be out of place from either the wind, shade from tall structures near the panel, or sun position due to the time of the year.

Yearly Maintenance

- Turn off Sipper controller.
- Remove and test the battery. Replace it if needed.
- Replace the inline particle filters on the air lines if needed.
- Contact Geotech for solar panel warranty confirmation and extension.

For technical assistance, call Geotech Environmental Equipment, Inc. at 1-800-833-7958.

Stainless Steel Pump and Skimmer

In order to provide a full and long service life, keep the Skimmer intake cartridge clear of debris or bio growth. The floating intake cartridge on the Skimmer is the heart of the Sipper system. Therefore, the intake cartridge (oleophilic/hydrophobic screen, float, float shaft, flexible intake hose and clamps) should receive periodic thorough inspections. The floating height of the intake screen should always stay above the waterline. The intake cartridge screen will not pass water unless:

1. The intake cartridge has risen to the top of its travel allowing water to rise above the top of the cartridge (thus indicating that the system should be raised to a height at which the intake is floating within its 12" (30.5 cm) to 24" (61 cm) of working travel).
2. An inordinate amount of debris is allowed to build up on the surface of the screen.
3. A detergent (surfactant) contacts the screen. (A detergent will "wet" the screen and allow water to pass.)

If the screen is found to be clogged with debris or has been submerged in water, a gentle rinsing in kerosene or gasoline is recommended. When the presence of detergents is suspected, samples should be taken and tested.

Since the pump and Skimmer assembly must be removed from the well to perform maintenance on the intake screen, such occasions should be used to carry out a general inspection of the entire assembly.

Use the maintenance procedures found in the Geotech Pump and Skimmer Assembly User Manual to properly care for your pump and Skimmer assemblies.

Solar Panel

On Solar Sipper applications, it is important to keep all debris, dust and dirt from accumulating on the solar panel surface. Clean the front surface of the solar panel as needed with mild soap and water. **DO NOT use abrasive cleaners, solvents or pads.** Simply rinsing off the panel with clean, clear water will usually suffice.

Solenoid Maintenance (Stuck Solenoid)

The following procedure outlines how to remove, dis-assemble, and clean a stuck solenoid plunger.

1. Remove plug on solenoid with Phillips screwdriver.

****Do not lose the gasket for the plug.***

2. Remove the three (3) screws and solenoid with a small flathead screwdriver (Figure 5-1).



Figure 5-1: Removing Solenoid

3. Using the small flathead screwdriver, remove the two (2) screws of the square metal cap (Figure 5-2).

****Note the black gasket on the underside Figure 5-2. If the gasket is lost or stolen, contact Geotech for a replacement gasket (PN: 16550353).***

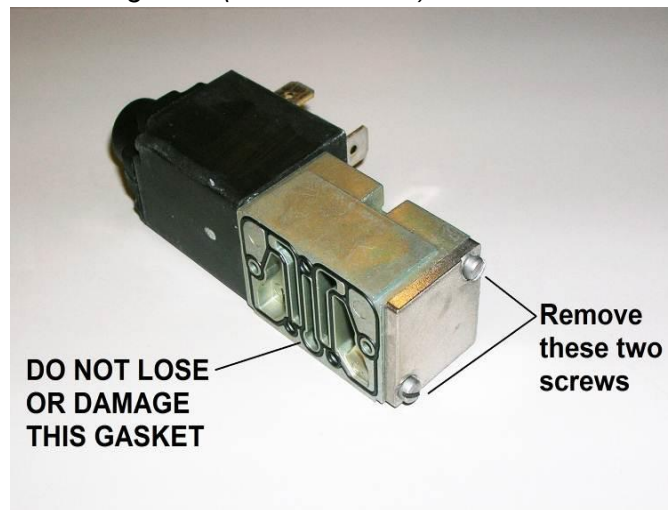

Figure 5-2: Gasket

- Carefully remove the spring, the O-ring, the bushing, and the plunger (Figure 5-3).

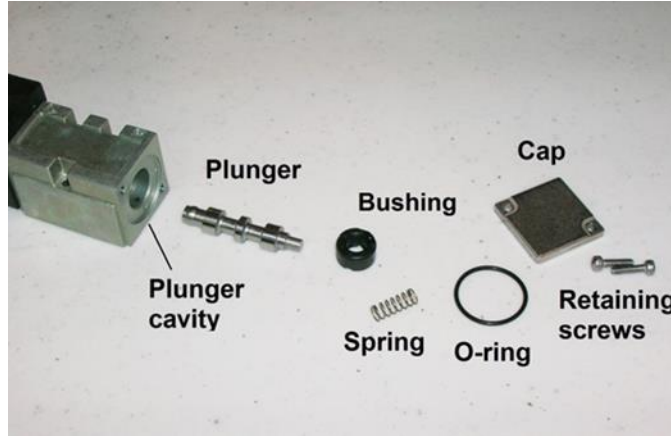

Figure 5-3: Solenoid Parts

- Clean the plunger and plunger cavity with a spray lubricant and cotton swab.
**Silicon based or aerosol lubricant OK.*
- Orient and insert the plunger as shown in Figure 5-4.

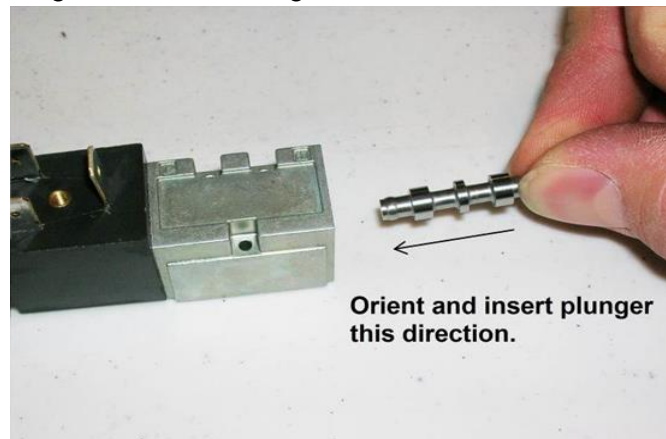

Figure 5-4: Solenoid Plunger

- Place the O-ring and bushing back into the opening (no orientation needed) followed by the spring (Figure 5-5).



Figure 5-5: Solenoid Spring

- Carefully place the square cap onto the end, compressing the spring, and reattach the two (2) screws. Make the connection snug but do not over tighten. (Figure 5-6)

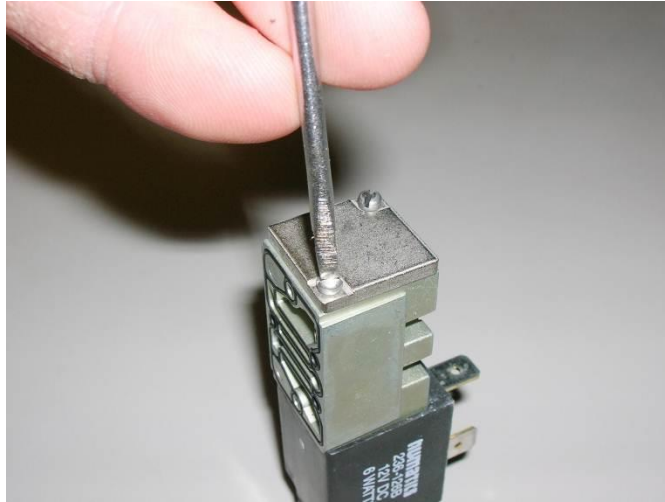

Figure 5-6: Replacing Solenoid Cap

- Verify that the plunger will move easily by depressing the small black button on the other end of the solenoid with a small Phillips screwdriver.
- After verifying the solenoid gasket is in place, re-attach the solenoid with the three screws
**Be very careful not to lose or allow the gasket to fall out of place and be crushed*
- After securing the solenoid, re-attach the plug with gasket to the solenoid.

If this procedure does not resolve a suspected vacuum/pressure problem, then please call Geotech Technical Sales for further troubleshooting advice @ 1-800-833-7953.

Optic Fluid Sensor Install/Replacement

Each Optic Sensor comes pre-wired and ready for install. Use the Analog/Non I.S. Input Terminals page of the wiring diagram to ensure the sensors are wired into the unit correctly.

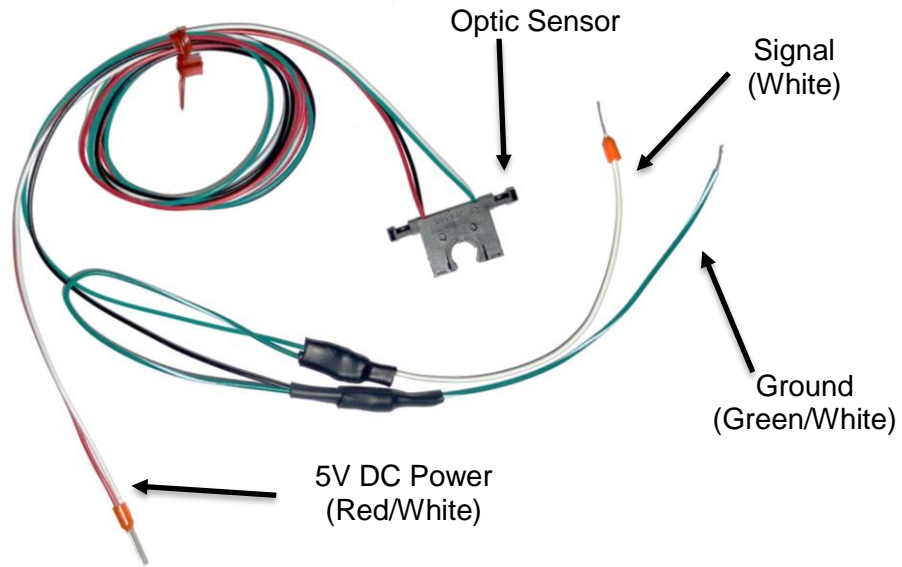

Figure 5-7: Optic Sensor

The following steps will use Well #1 as an example. If replacing a different well, ensure to follow the steps for that specific well input.

1. Install Intake Override sensor.

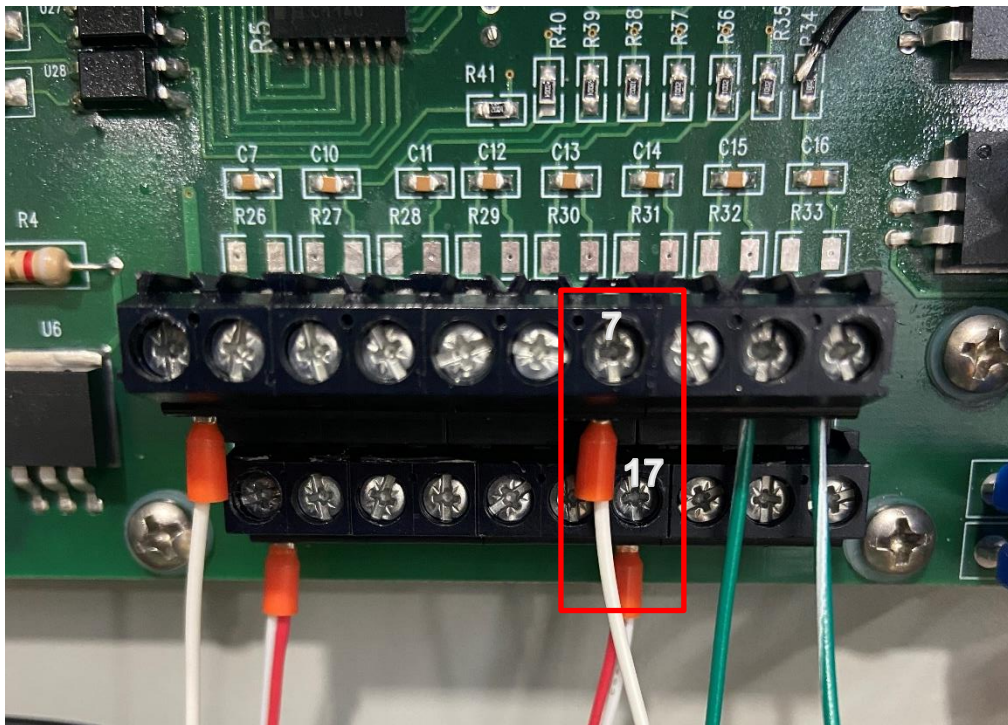

Figure 5-8: Intake Override input

2. Snap the optic sensor onto the appropriate well tubing near the bulkhead and place a zip tie to secure into place.
 - Orientation of sensor does not matter.



Figure 5-9: Optic sensor tubing installation

If this procedure does not resolve the issue, or if your system is equipped with an Intake Float Switch (see Figure 5-14), then contact Geotech Technical Sales for further troubleshooting advice @ 1-800-833-7953.



Figure 5-10: Intake Float Switch

Section 6: System Troubleshooting

Problem: No product is being recovered but system cycles and gauge indicates vacuum and pressure generation.

Solution:

- Inspect product hose for kinks and blockage. Replace if needed. If freezing conditions have occurred, check the discharge lines for frozen product.
- Remove and inspect the check valve at the top of the stainless steel pump. If the check ball is stuck in the UP position, clean and gently dislodge the ball. (Periodic replacement of the check valve may be required depending on duty cycle.)
- The check valve in the top of the pump may have been re-installed upside down. The arrow on the check valve should point away from the pump and toward the discharge tubing.
- The directional solenoid plumbed directly to the compressor could be stuck. If it is locked up, it may be cleared by depressing the small button on the black end of the solenoid using a small Phillips screwdriver or paper clip to actuate the solenoid manually. If this does not work, remove the small plate at the other end of the solenoid and clean the plunger and plunger cavity using the procedure found in *Section 5: System Maintenance*.
- Visually inspect the wiring connections to see that they are not loose or otherwise compromised.

Problem: System cycles but gauge does not indicate vacuum or pressure generation.

Solution:

- Inspect product hose for abrasion, cuts, or open connections. Replace if needed.
- Make sure the airline connection goes to the pump and that the vent connection (the exhaust) is plumbed to the recovery tank.
- Verify that there is product in the well. If so, verify that the Skimmer intake is at the correct level in the well so that product can be recovered.
- Open the controller panel and verify that all air line connections are intact.

Problem: A pump is stuck in either vacuum or pressure.

Solution:

- Inspect the solenoid for residue or debris. If it is locked up, it may be cleared by depressing the small button on the black end of the solenoid using a small Phillips screwdriver or paper clip to actuate the solenoid manually. If this does not work, remove the small plate at the other end of the solenoid and clean the plunger and plunger cavity using the procedure found in *Section 5: System Maintenance*.
- Visually inspect the wiring connections to see that they are not loose or otherwise compromised.

Problem: Solenoid continues to stick, even with frequent cleaning (as per *Section 5 – Solenoid Maintenance*).

Solution:

- System is operating in humid conditions, which can cause residue or debris to accumulate within the solenoid. System may be installed with optional Desiccant Dryers. See *Section 9: Parts and Accessories* for Desiccant Dryer information, or contact Geotech Technical Sales for assistance.

Problem: The screen is blank.



DO NOT TURN THE SIPPER SWITCH OFF AND ON AGAIN TO FORCE A CYCLE.

Solution:

- Press the UP arrow button. If the system is currently in a low voltage shut down, a low voltage display will be present. If all equipment is functional, then allow the unit time to recharge. See also the low battery definition in *Section 3: Timer/Cycle Settings and Display Descriptions*.
- Check for loose or damaged battery connections and solar panel connections.
- Use a voltmeter to test the battery voltage. If it is below 10V remove the battery and charge it on a separate charger to verify that a charge can be retained. Reconnect the battery and test the system. Otherwise, when the solar panel is exposed to enough sun, the battery will eventually recharge and the system will automatically resume normal operation.
- Turn off the power and check the main fuse.

Problem: The screen shows unintelligible characters.

Solution:

- Use a voltmeter and ensure the battery voltage is over 12.1V if not, remove the battery and charge it on a separate charger. Otherwise, when the solar panel is exposed to enough sun the battery will eventually recharge and the system will automatically resume normal operation.
- The screen display has no effect on the other hardware functions. If the voltage is over 12.1V, turn the ON/OFF switch to OFF and wait 60 seconds before switching on again.

Problem: System is displaying a Battery Fault Check Cables alarm.

Solution:

- Disconnect all voltage sources (battery, solar panel) then check Figure 2-3 and re-wire the solar panel and battery to the correct terminals.
- The fuse may have blown, check the fuse with a Multimeter and replace if necessary.
- Battery may have been overcharged by another charging system and may need to be replaced. Verify battery voltage with a voltmeter.
- Visually inspect the wiring connections to see that they are not loose or otherwise compromised.

Problem: System is displaying a TANKFULL alarm.

Solution:

- Recovery tank is full. Empty and restart the system.
- Tankfull probe is disconnected or cable is damaged. Inspect probe and cable. Replace if needed.
- Verify the tankfull float is not stuck in the UP position.
- If the tankfull alarm will not clear then contact Geotech for assistance.

Problem: System is displaying an INTAKE OVERRIDE alarm.

Solution:

- The Intake Sensor detects the presence of fluid. This is caused when product or moisture is pulled through the air line due to:
 1. Long cycle time on vacuum.
 2. The directional solenoid on the compressor is stuck.
 3. An accumulation of moisture in the air line during operation.

Allow the system to clear product out of the manifold and past the air filter. Disconnect the line and use a standalone air source. Do not use more than 100 PSI (6.9 bar) of pressure to finish evacuating the air line of product.

Temporarily set the vacuum to 0 and the pressure to 30. Allow the Sipper controller to clear product out of the lines. Once product has been cleared from the lines, adjust the vacuum and pressure to previous settings.

If fluid is seen in the line, replace tubing.

Problem: A pump and Skimmer assembly is not functioning, or has been removed from service, on a multiple pump system.

Solution:

- Set the vacuum, pressure, and delay for the inoperable pump to the lowest setting possible. Then disconnect the airline at the air filter on the side of the Sipper enclosure. The unit will continue to run all pumps in sequence with minimal use of battery power on the out of service pump.

Problem: Controller displays a low battery condition and the battery will not recharge.

Solution:

- If the system experienced freezing conditions, then the battery may be frozen. Place the battery in a warm spot and allow it time to thaw, then reconnect and let it re-charge as normal.
- Battery may need to be replaced. See wiring schematics in *Section 2: System Installation*.
- Additional solar panels may be required to keep the system running.
- Turn unit off and back on to reset the clock crystal.

Problem: Counters running slow.

Solution:

- Turn unit off and back on to reset the clock crystal.

Problem: Intake Override alarm prevents system from operating, when there is no fluid in the airline near the optical sensor.

Solution:

- Remove zip tie from Intake Override optical sensor, and remove sensor from airline attached to compressor. Attach the Intake Override optical sensor to a separate 2" piece of clear tubing. Schedule RMA for system servicing at Geotech as soon as practical.

If your solution cannot be found within this section, please call Geotech Technical Sales for expert troubleshooting advice @ 1-800-833-7958.

Section 7: System Specifications

Applications	2" (5.8 cm) or larger recovery wells
Recovery Rate	.2 gallons (.76 liters) per cycle
Max. Operating Depth	180' (54.86 m)
Max. Pressure	100 PSIG (7 bar)
Max. Vacuum	20" (50 cm) Hg @ MSL (mean sea level)
Oil/Water Separation	Oleophilic/hydrophobic mesh screen

Power

Power Maximums	(AC Sipper) 87 to 240VAC, 2.7 to 1 Amp(s) (Solar Sipper) 12-15VDC input @ up to 14.5 Amps 90 ~240 Watts continuous
----------------	--



Power usage will vary depending on application.

Controller

Operating Temperature	32° to 104° F (0° to 40° C)
Storage Temperature Range	-20° to 150° F (-29° to 66° C)
Humidity	90% non-condensing (max)
Size	10" D x 18" T x 16" W (25cm D x 46cm T x 40.5cm W)
Rating	NEMA 3R
Approximate Weight	35 lbs (16 kg) (single channel AC Sipper)
Approximate Weight	34 lbs (15 kg) (single channel Solar Sipper)
Approximate Weight	51 lbs (23 kg) (seven channel AC Sipper)
Approximate Weight	49 lbs (22 kg) (seven channel Solar Sipper)
Fittings	.17 x 1/4" MPT Brass Hose barb



Additional customizations and accessories could add more weight.

Pump Assembly

Size:	23.5"L x 1.75" OD (60 cm L x 4.5 cm OD)
Weight:	4.5 lbs. (2 kg)
Materials:	303 and 304 SS, flexible rubber tubing, PVC, Brass

Skimmer Assembly

	2" Model	4" Model
Effective travel range:	12" (30.5 cm)	24" (61 cm)
Size:	35.5" L x 1.75" OD (90 cm L x 4.4 cm OD)	35.5" L x 3.75" OD (90 cm L x 9.5 cm OD)
Weight:	1.75 lbs. (.8 kg)	2.25 lbs. (1.02 kg)
Operating Temperature:	32° to 104° F (0° to 40° C)	
Storage Temperature:	-20° to 150° F (-29° to 66° C)	
Materials:	304 SS, Polyethylene, PVC, Polypropylene, Brass	
Tubing - Air:	.17" ID x .25" OD (4 mm ID x 6 mm OD)	
Tubing - Discharge:	.375" ID x .5" OD (9.53 mm ID x 12.7 mm OD)	

Solar Panel:

Rated Power	100 Watts (standard unit)
Operating Voltage	17.4 VDC
Maximum Voltage	21.5 VDC
Operating Amperage	4.88 Amps (standard unit)
Maximum Amperage	5.8 Amps
Size:	43.31" X 28.15" X 3.15" (110 cm X 71.5 cm X 8 cm)
Approx. Weight:	19.62 lbs (8.9 kg)

Solar Panel Mounting System:

Module Tilt Range	15 to 65 degrees
Pole Size	2" (5 cm), 4" (10 cm), and 6" (15cm)
Module Orientation	Landscape/Portrait
Max Wind Speed	125 mph (200 kph)
Wind Exposure	Category B & C
Materials	5052-H32 Aluminum Powder Coated Steel Stainless Steel Fasteners

Ground/Roof Mount

Module Tilt Range	0 to 90°
Module Orientation	Landscape/Portrait
Wind Speed Max	Dependent on mounting
Wind Exposure	Dependent on mounting
Materials	Powder Coated Steel Stainless Steel Fasteners

Cellular Radio Specifications

Cellular Network	2G to 4G LTE, NB-IoT, 5G, CAT-M, and eSIM (Most global cellular networks available) 4FF Nano
End Device Certified (LTE-M)	AT&T, Verizon, Bell, Telus
Compatible with other carriers offering LTE-M and NB-IoT services	Bands 1, 2, 3, 4, 5, 8, 12, 13, 18, 19, 20, 25, 26, 28 and 39
Regulatory Approvals	FCC (USA) MCQ-XB3M1 IC (CANADA) 1846A-XB3M1 CE / RED (EUROPE) Complete RCM (AUSTRALIA/NEW ZEALAND) Complete

FCC certified and carrier end-device certified

Section 8: System Schematics

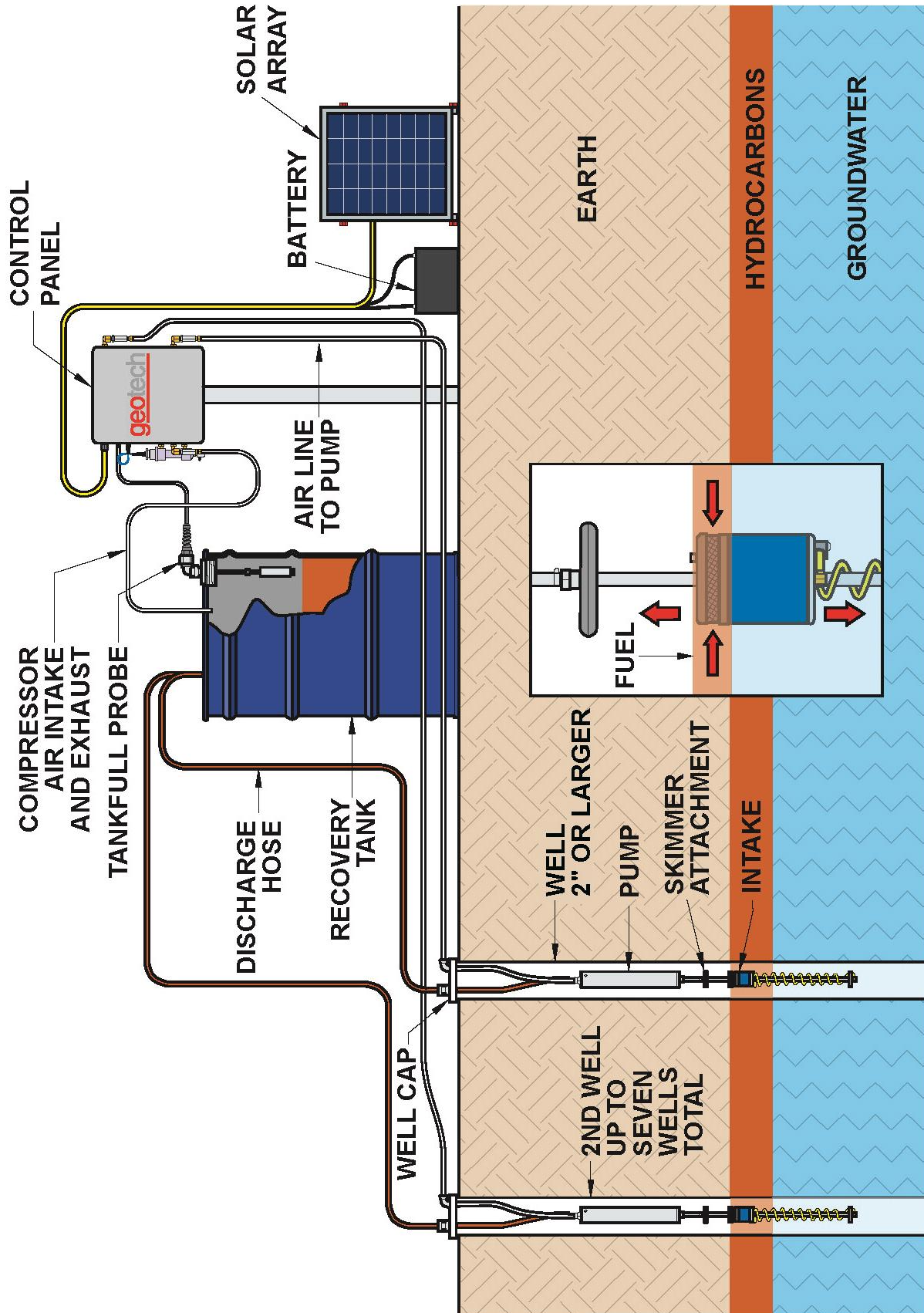

Figure 8-1: Solar Sipper Schematic

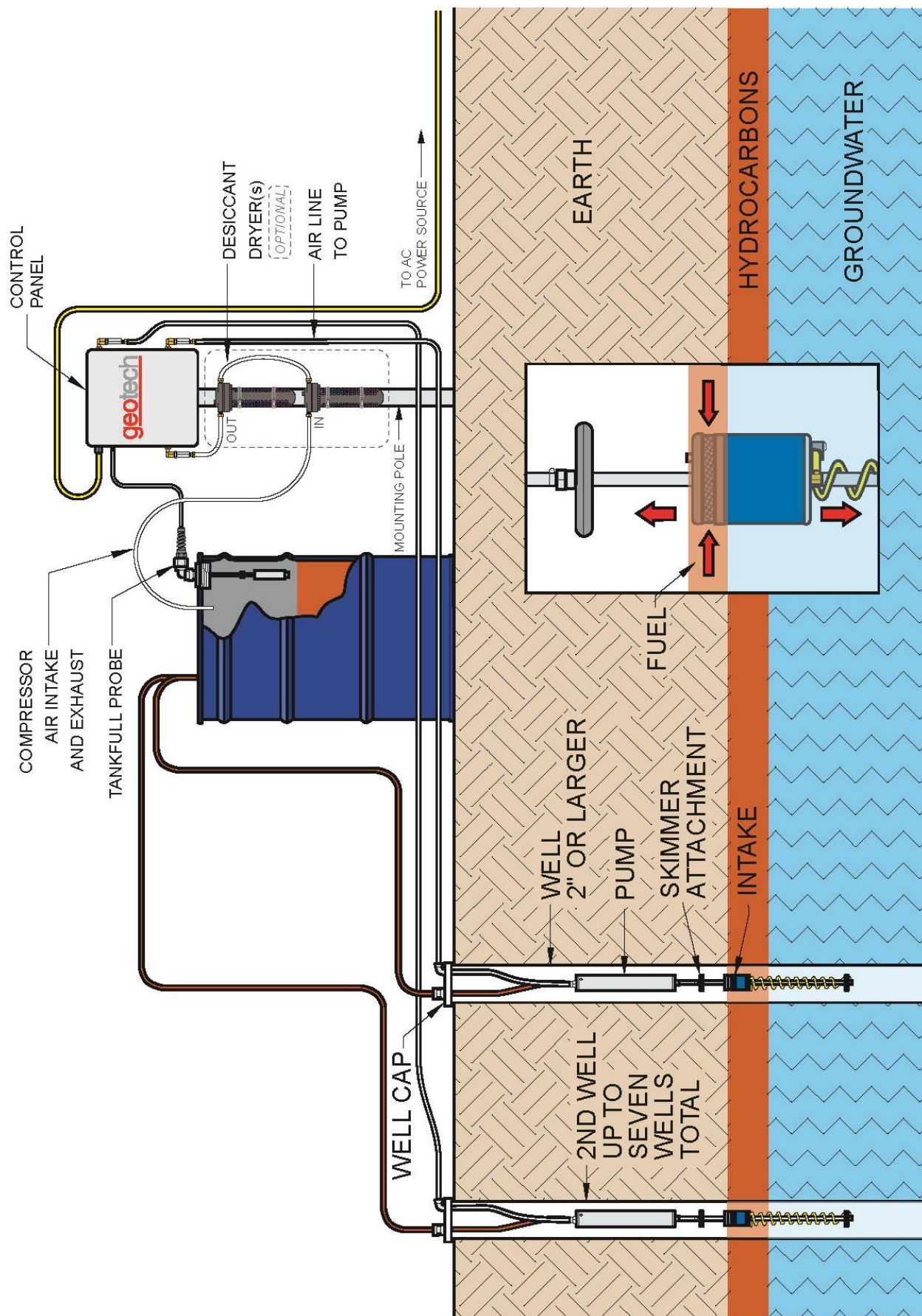

Figure 8-2: AC Sipper Schematic, shown with optional Desiccant Dryers

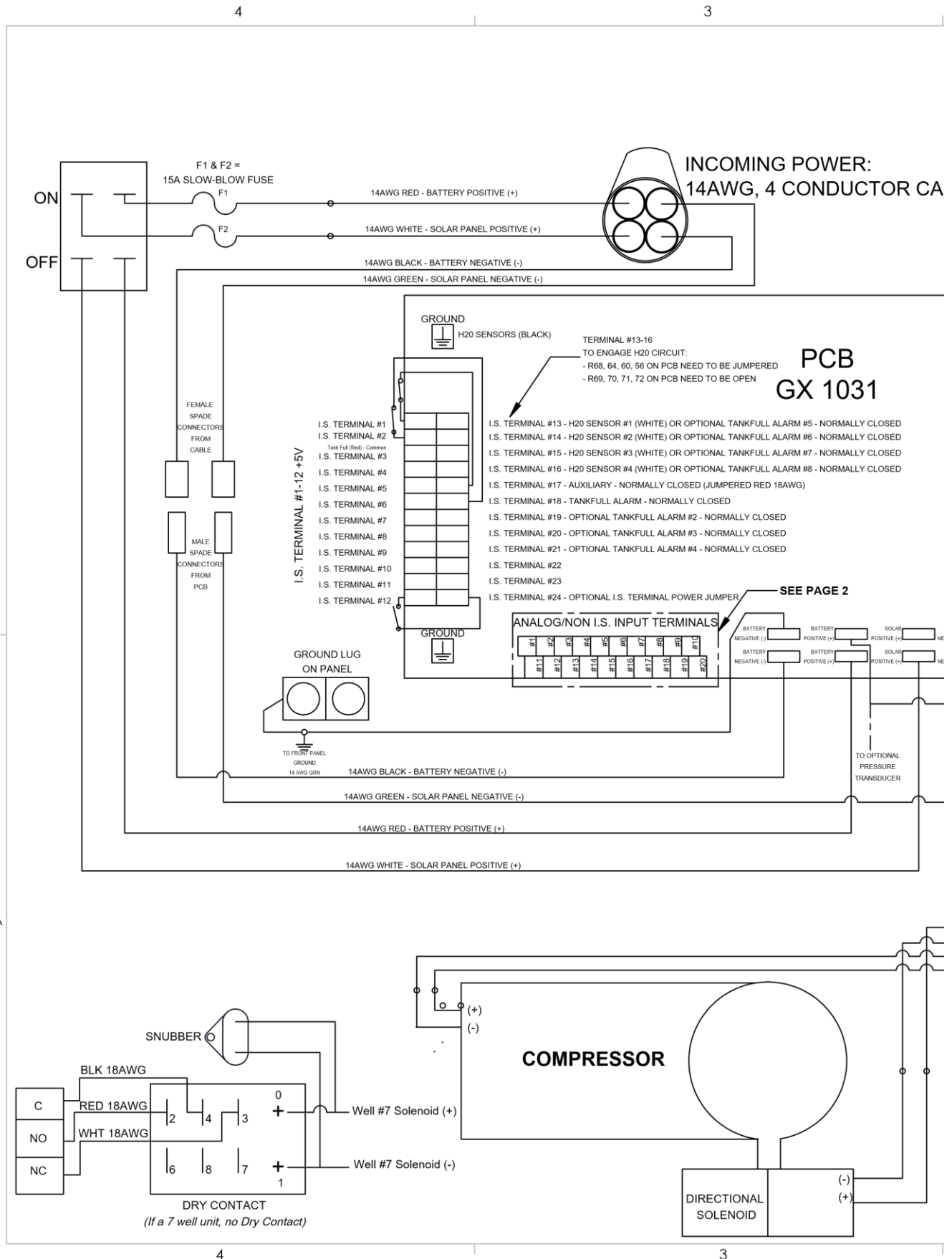
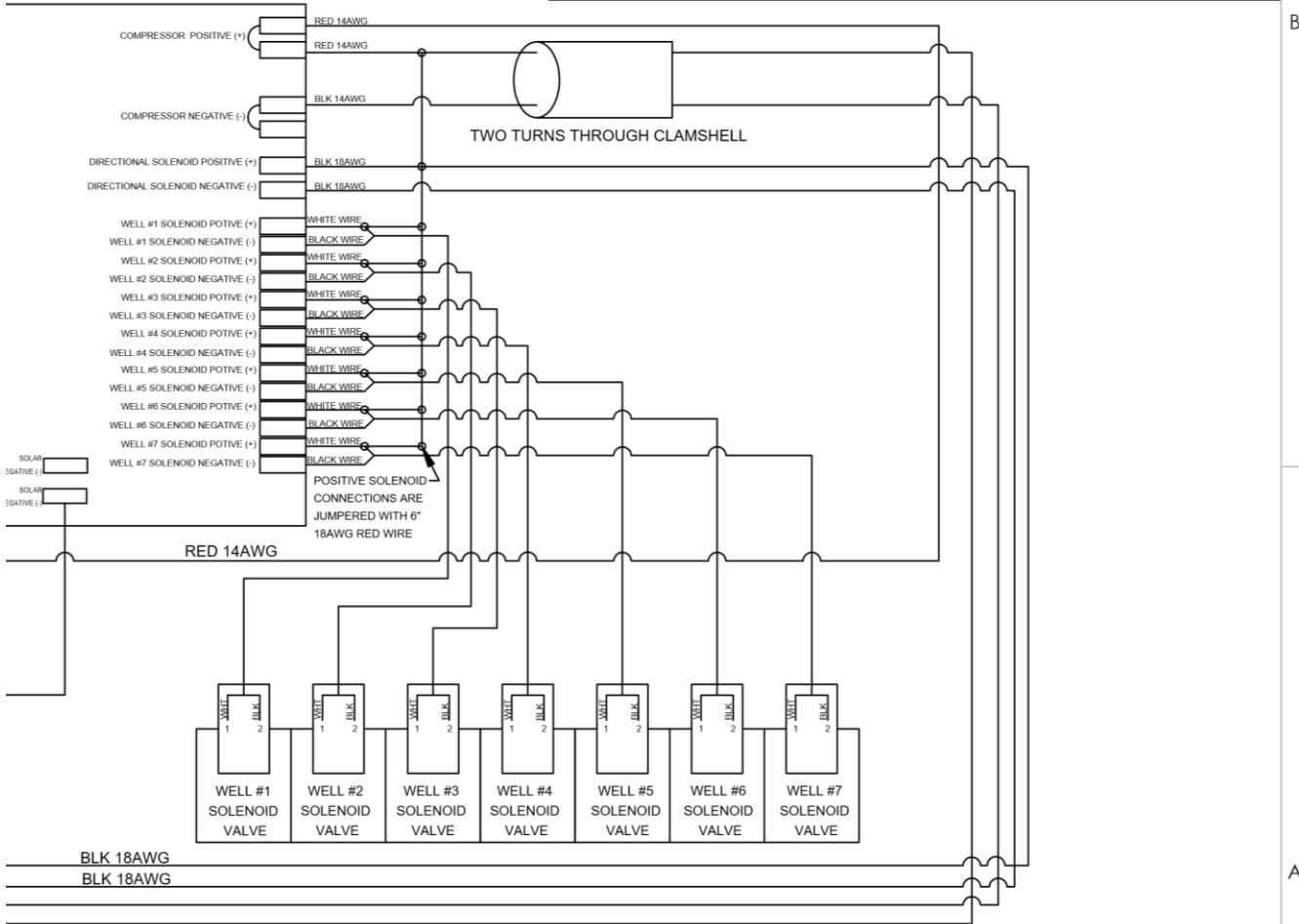

Figure 8-3: 7 Well Solar Sipper Internal Wiring Diagram

BLE THRU STRAIN RELIEF

REVISION HISTORY			
EDCF	REV	DESCRIPTION	DATE
-	-	Release	12/13/2010
1681	A	Edit Analog Input Terminal note, SP	10/24/2013
-	B	Corrected power to compressor, SP	6/11/2014
-	C	Updated to include Water Sensor input, SP	3/10/2015
Project 1855	D	Re-drawn in Solidworks. Added Page 2 - Analog/Non IS input terms. Removed IS term conn #3 to #20. Removed jumper on pressure release solenoid (-). Removed note on non i.s. term #20 for ext. 24-36 vdc power supply (+) and added +5vdc to non i.s. term #20 - StellaR	11/15/2019
Project 1855	E	Changed Solar Panel Negative from White to Green - StellaR	1/6/2020
Project 1855	F	Changed Ground green wire to sensor terminal inputs. 1-4 to #9, 5-8 to #10 (was all ground sensor connected together) - StellaR	2/5/2020
Project 1855	G	Swapped Solar Positive and Negative positions on PCB - StellaR	2/11/2020
Project 2008	H	Page 1: Rem'd 14awg green from Batt (-), Page 2: Updated all from Sensor # to Well # Sensor to well 6. Added Intake Override and optional Pressure Transducer. Updated aforementioned wire conns - StellaR	11/9/2020
Project 2008	I	On IS Terminal #13-21: Added optional tankfull alarm # - normally closed. On well solenoids, changed wire colors: red to white; white to black. Added clamshell - StellaR	1/28/2021
Project 2176	J	Added dry contact - StellaR	7/1/2021
Project 2176	K	Added snubber to dry contact - GR	5/2/2022
	L	Added ground wire from PCB "Battery Negative" to ground lug and removed Sensors 1-6. - LL	8/1/2022
Project 2298	M	Removed 8th well option. - GR	5/24/2023



VALIDATION	MATERIAL	---	APPROVALS	DATE	Geotech Environmental Equipment, Inc. 2650 East 40th Avenue Denver, CO 80205 1-800-633-7958
	DWG INTERPRETATION PER ANSI Y14.5M-1994		ENG CAD	11/15/19	
THE INFORMATION CONTAINED IN THIS DRAWING IS THE SOLE PROPERTY OF GEOTECH ENVIRONMENTAL EQUIPMENT. ANY REPRODUCTION IN PART OR AS A WHOLE WITHOUT THE WRITTEN PERMISSION OF GEOTECH ENVIRONMENTAL EQUIPMENT IS PROHIBITED.	-TOLERANCE- UNLESS OTHERWISE SPECIFIED DIMENSIONS ARE IN INCHES	DECIMALS X : 02 XX : 01 XXX : 005 ANGLES : 0°30' FRACTIONS : 1/32	MS CAD		SHEET DWG NO. B 4907 M
				INVENTORY P/N	-

ANALOG/NON I

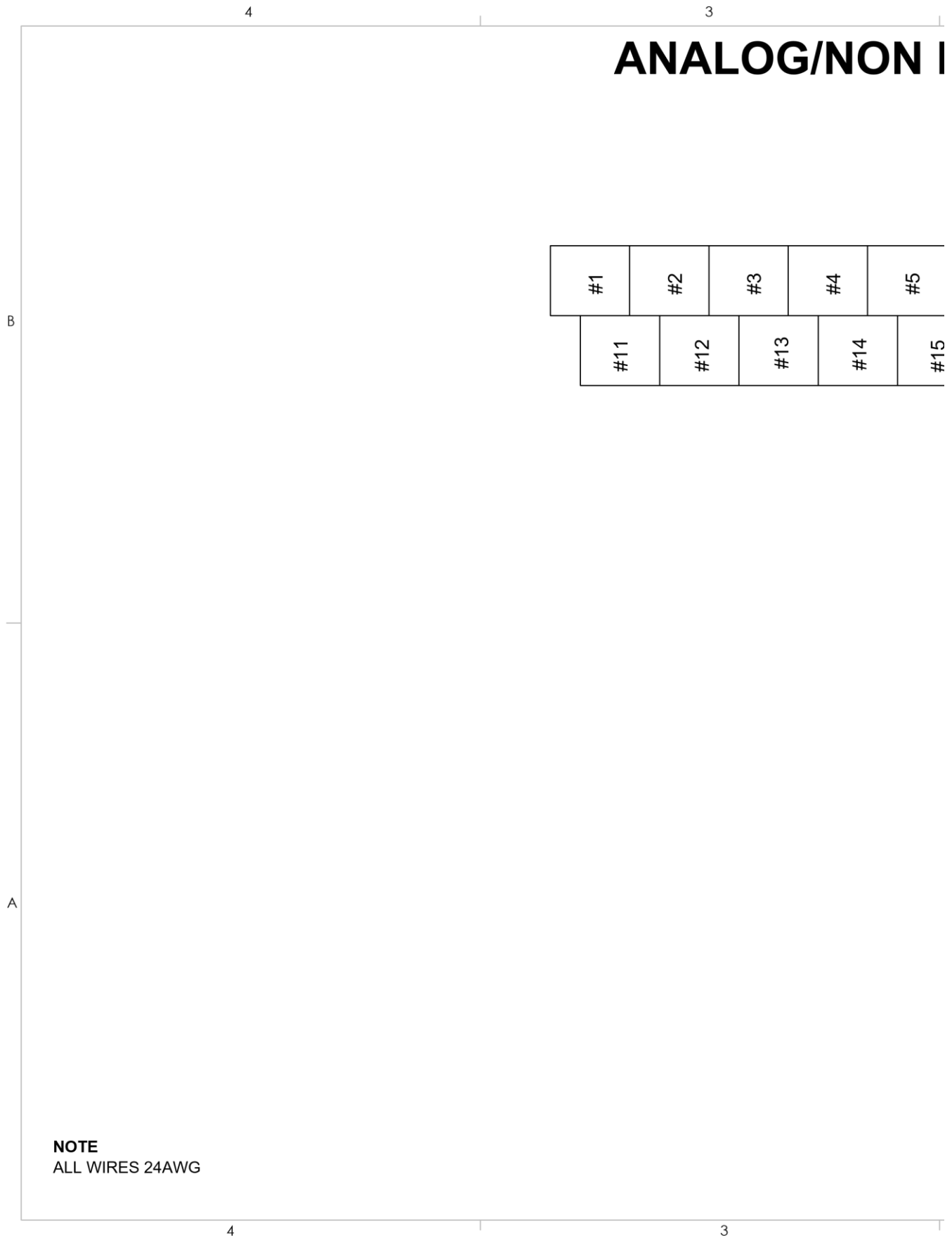

NOTE
ALL WIRES 24AWG

Figure 8-4: Solar Sipper Analog/Non I.S. Input Terminals

I.S. INPUT TERMINALS

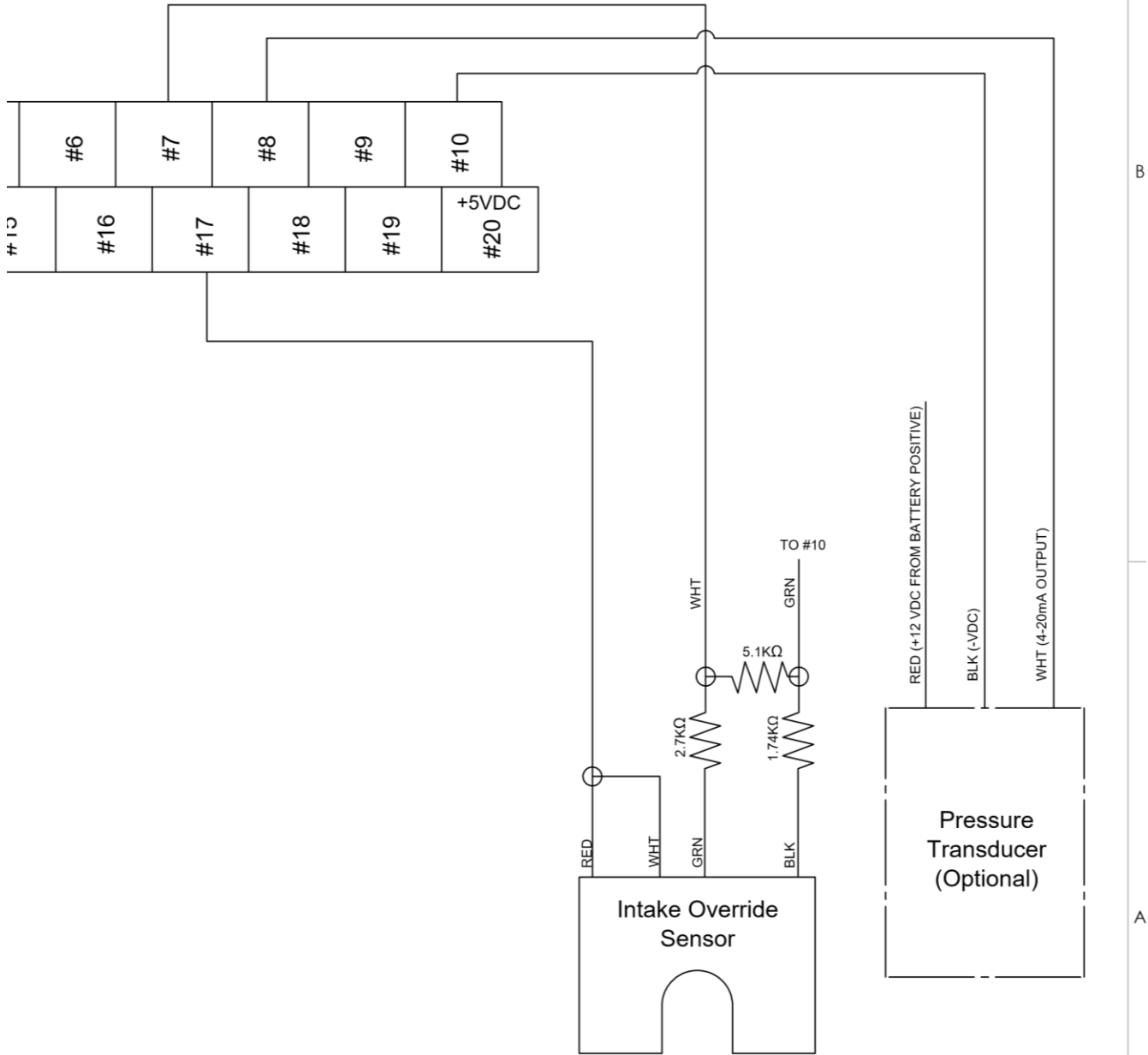

VALIDATION	MATERIAL	APPROVALS	DATE	Geotech Environmental Equipment, Inc. 2650 East 40th Avenue Denver, CO 80205 1-800-833-7958
	DWG INTERPRETATION PER ANSI Y14.5M-1994 -TOLERANCE- UNLESS OTHERWISE SPECIFIED DIMENSIONS ARE IN INCHES	ENG CAD StellaR 11/15/19		
THE INFORMATION CONTAINED IN THIS DRAWING IS THE SOLE PROPERTY OF GEOTECH ENVIRONMENTAL EQUIPMENT. ANY REPRODUCTION IN PART OR AS A WHOLE WITHOUT THE WRITTEN PERMISSION OF GEOTECH ENVIRONMENTAL EQUIPMENT IS PROHIBITED.	DECIMALS X ±.02 XX ±.01 XXX ±.005	MS CAD		SHEET DWG NO. B 4907
	ANGLES : 0°30' FRACTIONS : 1/32	INVENTORY P/N		
				SCALE 1:1 DO NOT SCALE DWG SHEET 2 OF 2

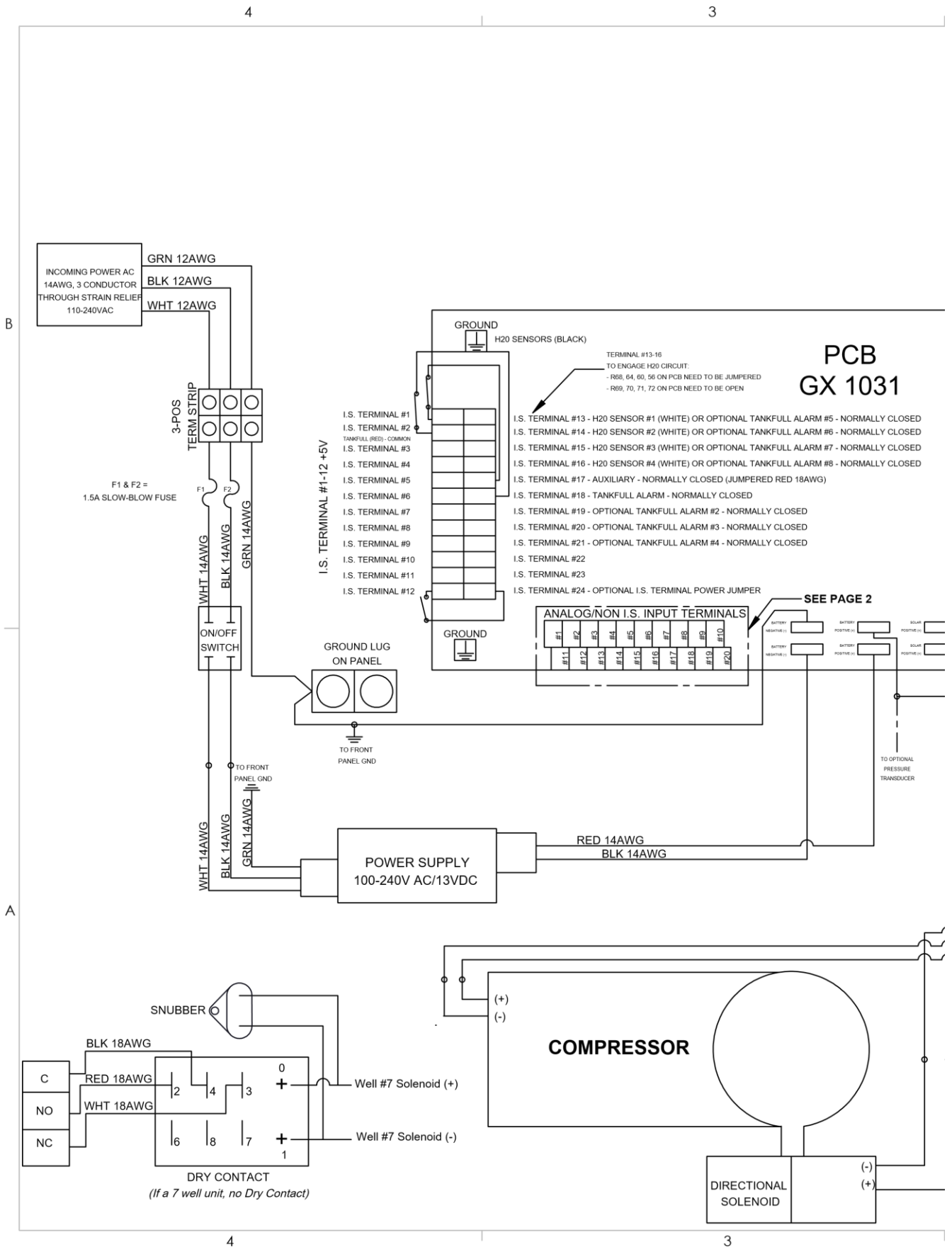
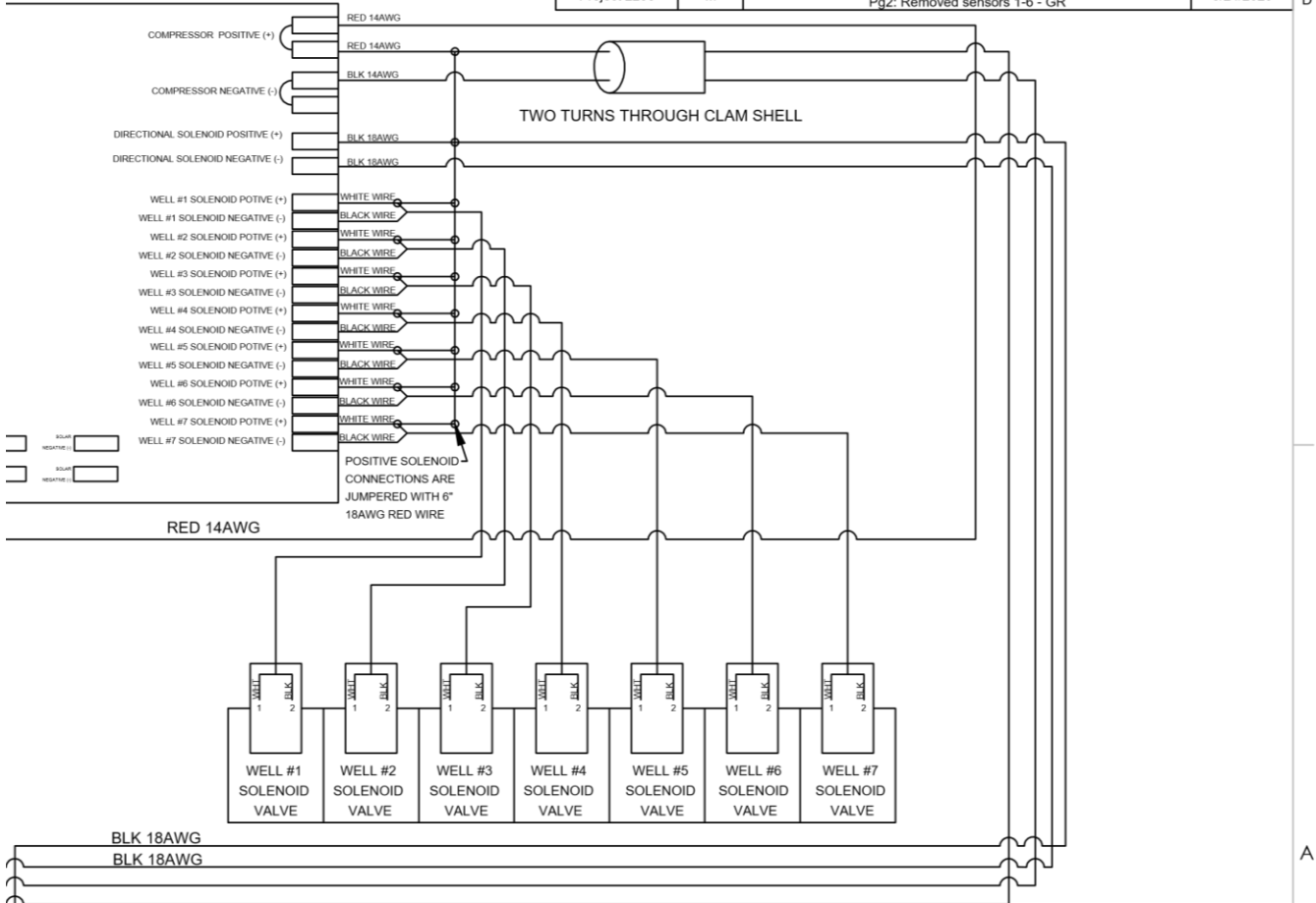

Figure 8-5: 7 Well AC Sipper Internal Wiring Diagram

REVISION HISTORY			
EDCF	REV	DESCRIPTION	DATE
1682	-	Release, SP	10/27/2013
-	A	Corrected missing power (+) to solenoid compressor, SP	6/2/2014
1796	B	Changed fuse value to 1.5A, moved fuse upstream of power switch, SP	7/18/2014
-	C	Moved tankfull to terminal #18 (was #17), added H2O sense circuit details, SP	5/1/2015
2106	D	Moved tankfull to terminal #17 (was #18) - StellaR	10/4/2019
2573	E	Redrawn in SW, corrected wire connection to terminal #17, added 1, 2 connections in solenoids - StellaR	9/12/2019
Project 1855	F	Added Page 2 - Analog/Non IS input terminals. Removed IS terminal connection #3 to #20. Removed jumper on pressure release solenoid negative. Removed not on non i.s. terminal #20 for external 24-36 vdc power supply positive" and added +5vdc to non i.s. terminal #20 - StellaR	11/12/2019
Project 1855	G	Changed Ground green wire on sensor terminal inputs. 1-4 to #9, 5-8 to #10 (was all ground sensor connected together) - StellaR	2/4/2020
Project 1855	H	Swapped Solar Positive and Negative positions on PCB board - StellaR	2/11/2020
Project 2008	I	Page 1: Updated IS Term inputs #17 (Aux) and Term inputs #18. Remv'd GRN from batt (-). Remv'd red wire from Batt (+) to well solenoids. Page 2: Updated all from Sensor # to Well # Sensor to well #6. Added Intake override and optional transducer. Updated aformentioned conns - StellaR	11/9/2020
Project 2008	J	On IS Terminal #13-21: Added optional tankfull alarm # - normally closed. On solenoid, changed wire colors: red to white; white to black. Corrected not for Terminal 13. Line 2: R68, 64, 60, 56 - StellaR	1/28/2021
Project 2176	K	Added Dry Contact - StellaR	7/1/2021
Project 2176	L	Added snubber to dry contact - GR	5/2/2022
Project 2298	M	Pg1: Removed 8th well option. Added ground wire from PCB Battery (-). Pg2: Removed sensors 1-6 - GR	5/24/2023



VALIDATION

THE INFORMATION CONTAINED IN THIS DRAWING IS THE SOLE PROPERTY OF GEOTECH ENVIRONMENTAL EQUIPMENT. ANY REPRODUCTION IN PART OR AS A WHOLE WITHOUT THE WRITTEN PERMISSION OF GEOTECH ENVIRONMENTAL EQUIPMENT IS PROHIBITED.

MATERIAL ---

DWG INTERPRETATION PER ANSI Y14.5M-1994

UNLESS OTHERWISE SPECIFIED

TOLERANCE - DIMENSIONS ARE IN INCHES

DECIMALS X ±.02
XX ±.01
XXX ±.005

ANGLES : 0°30'
FRACTIONS : 1/32

APPROVALS

ENG CAD StellaR

DATE 9/11/19

MS CAD

INVENTORY P/N -

geotech Geotech Environmental Equipment, Inc.
2650 East 40th Avenue
Denver, CO 80205
1-800-833-7958

8 WELL AC SIPPER, WIRING DIAGRAM

SHEET DWG NO. **B 5474** REV **M**

SCALE 1:1 DO NOT SCALE DWG SHEET 1 OF 2

4

3

ANALOG/NON I.S.

B

#1	#2	#3	#4	#5	
#11	#12	#13	#14	#15	

A

NOTE
ALL WIRES 24AWG

4

3

Figure 8-6: AC Sipper Analog/Non I.S. Input Terminals

S. INPUT TERMINALS

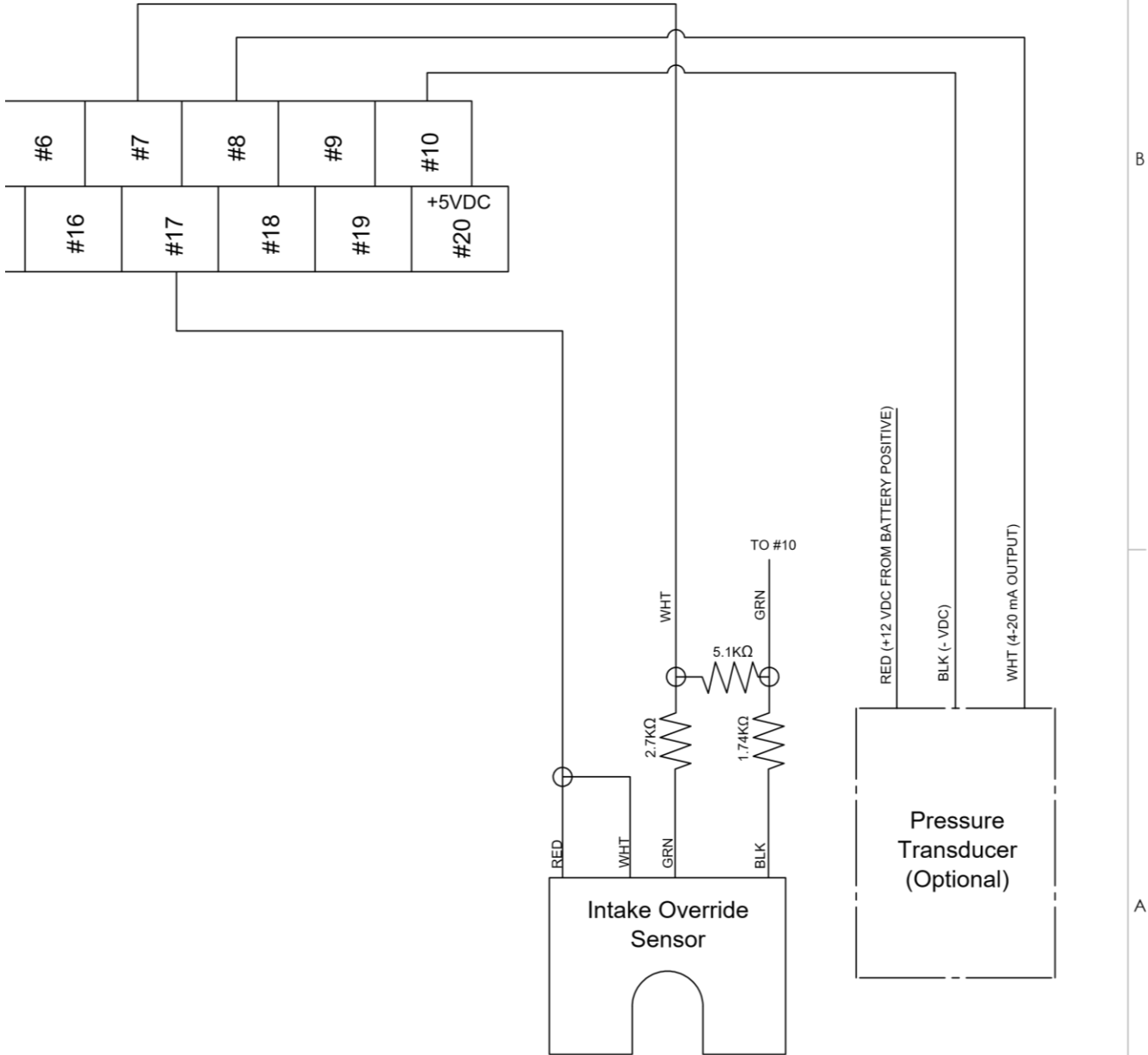

VALIDATION	MATERIAL	APPROVALS	DATE	Geotech Environmental Equipment, Inc. 2650 East 40th Avenue Denver, CO 80205 1-800-833-7958
	DWG INTERPRETATION PER ANSI Y14.5M-1994 -TOLERANCE- UNLESS OTHERWISE SPECIFIED DIMENSIONS ARE IN INCHES	ENG CAD StellaR	9/11/19	
THE INFORMATION CONTAINED IN THIS DRAWING IS THE SOLE PROPERTY OF GEOTECH ENVIRONMENTAL EQUIPMENT. ANY REPRODUCTION IN PART OR AS A WHOLE WITHOUT THE WRITTEN PERMISSION OF GEOTECH ENVIRONMENTAL EQUIPMENT IS PROHIBITED.	DECIMALS X ±.02 XX ±.01 XXX ±.005	MS CAD		SHEET DWG NO.
	ANGLES : 0°30' FRACTIONS : 1/32	INVENTORY P/N		B 5474
				SCALE 1:1 DO NOT SCALE DWG SHEET 2 OF 2

Section 9: Parts and Accessories

Description	Part Number
MANUAL, SOLAR SIPPER	16550176
MANUAL, SIPPER PUMP & SKIMMER ASSEMBLY	16550181
MOUNTING HARDWARE TABS (FEET)	16110181
FUSE HOLDER ASSEMBLY	2010029
COMPRESSOR,PRO,SIPPER	11150325
SOL/SPRING,2POS,12VDC,1/8"NPT	16550262
SOLENOID,GEOCONTROL PRO	11150249
RELAY, 12VDC, 30A, DPDT	12050521
GASKET, SIPPER VALVE, 20/PK FOR VALVE 16550262	16550353
ORING,SIPPER VALVE,20/PK	16550352
SIPPER TANK, MANIFOLD, 2 WELL	56550050
SIPPER TANK, MANIFOLD, 3 WELL	56550051
SIPPER TANK, MANIFOLD, 4 WELL	56550052
SIPPER TANK, MANIFOLD, 5 WELL	56550053
SIPPER TANK, MANIFOLD, 6 WELL	56550054
SIPPER TANK, MANIFOLD, 7 WELL	56550055
ASSY, PCB, GX1031, MULTICHANNEL	56550029
F1: FUSE, 160mA, 5X20, FAST ACT	10333
F3: FUSE, 2A, SLOW BLOW, 5X20mm	16110014
AC Sipper	
CABLE,MOTORLEAD,12/3,SEOPRENE SEOOW,YELLOW	17050002
ASSY, POWER SUPPLY, AC SIPPER	56600090
FUSE,1.5A,250V,SLO-BLO	PPE011025
Solar Sipper	
CABLE,SEO,14/4,YELLOW	10014
FUSE,15A,MDL TYPE	PPE011035
Solar Panel	
SOLAR PANEL WITH FRAME,100 WATT	86550007
SOLAR PANEL,100 WATT	16550251
MOUNTING RACK,SOLAR PANEL	16550252
CABLE,THW,12AWG SUBMERSIBLE PUMP,BLACK/RED,RIBBON	11200479
BATTERY,SOLAR AGM,104 AH,12V	16550253
FLAT MOUNT,SOLAR PANEL	16550356
Float Switch Assemblies	
PROBE, TANKFULL, SOLAR SIPPER 25'	56650100
ASSY,OPTIC-SENSOR,SIPPER	56550049

Sipper Well Cap and Tubing Accessories

WELL CAP,2",SLIP W/ CMPRSN FTG SIPPER	86600061
WELL CAP,4",SLIP W/ CMPRSN FTG SIPPER	86600062

Sipper Tubing (Air) – available by the foot or in 500’ rolls.

TUBING,PE,.170x1/4,FT POLYETHYLENE	87050501
TUBING,TLPE,.170x1/4,FT FEP LINED POLYETHYLENE	87050529
TUBING,FEP,.170x1/4,FT FEP	87050509

Sipper Tubing (Discharge) – available by the foot or in 500’ rolls.

TUBING,RBR,3/8x5/8,FT PRODUCT DISHCARGE	16600019
TUBING,TLPE,3/8x1/2,FT FEP LINED POLYETHYLENE	87050506
TUBING,FEP,3/8x1/2,FT FEP	87050511

Tubing Clamps

CLAMP,NYL,1/4" SNAPPER	11150259
CLAMP,SS,STEPLESS EAR,17MM	16600004
CLAMP,SS6,WORM,7/32-5/8"	16600063

Optional Parts and Accessories

REBUILD KIT,COMPRESSOR,SIPPER PRO	11150334
DESICCANT AIR DRYER,1/4"NPT,10CFM,150PSI,GEOTECH	56550057
SILICA GEL,DESICCANT DRYER REFILL,SINGLE PACK,1.8LBS	26600308
SITEVIEW,SETUP FEE,PER RADIO	12350014
SITEVIEW,15 MINUTE LOGGING ANNUAL DATA AND CLOUD SERVICES	12350012
RF TXRX,CELL,4G LTE,AT&T/VERIZ	12350000
ANTENNA,CYCLOPS,3G/2G,WALL MT	12050954
DRUM,55GAL,STEEL,EPOXY LINED,BLUE,W/2&3/4 BUNG	10759

**Systems equipped with Telemetry send Text Message Alarms from the system.
Ask your Geotech Sales Representative for more information.*

Sipper Pump and Skimmer Parts and Accessories

See “Geotech Pump and Skimmer Assembly Installation and Operation Manual” (P/N 16550181), for a complete description and listing of available pumps, skimmers, and their accessories.

DOCUMENT REVISIONS		
EDCF#	DESCRIPTION	REV/DATE
-	Previous Release	2/15/2013
1583	Added Compressor Repair Kit to Replacement Parts List. Added Revision History Table - SP	5/24/2013
1713	Edited Section 9: Parts and Accessories – Solar Panel now 100 Watts (was 85 Watts), updated Solar Panel Specs - SP	12/18/2013
1725	Edited Section 3: Timer/Cycle Settings and Display Descriptions – Factory Default timers will be set to 0 seconds for vacuum, pressure, and delay – SP	1/10/2014
Project 1377	Added Desiccant Dryer Kit details to Section 4: System Operation, Section 6: System Troubleshooting, and Section 9: Parts and Accessories – SP	1/10/2014
Project 1411	Edited Section 3: Timer/Cycle Settings and Display Descriptions – Factory Default timers will be set to 1 second of vacuum, 30 seconds of pressure, 5 minutes of delay – SP	3/21/2014
-	Added Desiccant Dryer Installation Guide, updated 8- well wiring diagram (rev B) - SP	1/5/2014
Project 1976	Updated new AC Sipper Power supply PN. Added Wireless Telemetry Communication parts to accessories list, updated Solar Panel wire colors, 3-well and 8-well page footers. -JH	6/14/2016
1993	General Formatting and Checking for Accuracy. Changed part number for power supply to 56600090 - StellaR	10/12/2017
-	Added AC Wiring Diagrams and replacement fuse, clarified Fluid Viscosity – StellaR	7/19/2018
Project 1765	Added detailed timer description, clarified text. Changed specifications to match spec sheet. Added mounting specification, added desiccant replacement instructions – StellaR	5/10/2019
Project 1805	Added PN 16550352 to parts list – StellaR	7/26/2019
Project 1855	Removed intake float and added intake switch. Added intake switch notes. Updated 8 Well AC and Solar wiring diagrams. Updated Solar Panel wiring diagram. Added Optic Sensor installation instructions. Added new PN for optic sensor. Updated images to remove intake float switch. Updated figure 8-3 to 8-6. – StellaR/LL	2/13/2020
Project 1970	Added PNs 56550050-0056 – StellaR	4/17/2020
Project 1993	Added fitting size in specs – StellaR	7/1/2020
Project 2008	Updated displays, added SitePro, updated displays updated flow chart, updated wiring diagrams. Updated figures 3-1 and 2-4. - StellaR	3/25/2021
Project 2160	Updated content to explain conductivity sensor and how to configure controller for conductivity sensor. – StellaR	6/8/2021
Project 2176	Added cycle priority, dry contact, advanced configuration and updated wiring diagrams – StellaR	10/2/2021
Project 2008	Added fuse part numbers for changes to PCB - GR	12/8/2021
Project 2176	Updated drawings for addition of snubber. Added new figure 3-1, and renamed subsequent figures. - GR	5/4/2022
Project 2204	Added PNs 56550057 and 26600308. Removed OBS PNs 56550048 and 16600323 for changes to desiccant. Updated Desiccant Maintenance and Replacement drawings and instructions.- GR	6/14/2022
Project 2298	Removed 8 th well option and reduced down to 7. Updated Images and drawings. Reorganized figures and layout. – AH and GR	5/24/2023

NOTES

NOTES

The Warranty

For a period of one (1) year from date of first sale, product is warranted to be free from defects in materials and workmanship. Geotech agrees to repair or replace, at Geotech's option, the portion proving defective, or at our option to refund the purchase price thereof. Geotech will have no warranty obligation if the product is subjected to abnormal operating conditions, accident, abuse, misuse, unauthorized modification, alteration, repair, or replacement of wear parts. User assumes all other risk, if any, including the risk of injury, loss, or damage, direct or consequential, arising out of the use, misuse, or inability to use this product. User agrees to use, maintain and install product in accordance with recommendations and instructions. User is responsible for transportation charges connected to the repair or replacement of product under this warranty.

Equipment Return Policy

A Return Material Authorization number (RMA #) is required prior to return of any equipment to our facilities, please call our 800 number for appropriate location. An RMA # will be issued upon receipt of your request to return equipment, which should include reasons for the return. Your return shipment to us must have this RMA # clearly marked on the outside of the package. Proof of date of purchase is required for processing of all warranty requests.

This policy applies to both equipment sales and repair orders.

FOR A RETURN MATERIAL AUTHORIZATION,
PLEASE CALL OUR SERVICE DEPARTMENT AT 1-800-833-7958

Model Number: _____

Serial Number: _____

Date of Purchase: _____

Equipment Decontamination

Prior to return, all equipment must be thoroughly cleaned and decontaminated. Please make note on RMA form, the use of equipment, contaminants equipment was exposed to, and decontamination solutions/methods used.

Geotech reserves the right to refuse any equipment not properly decontaminated. Geotech may also choose to decontaminate equipment for a fee, which will be applied to the repair order invoice.

Geotech Environmental Equipment, Inc
2650 East 40th Avenue Denver, Colorado 80205
(303) 320-4764 • **(800) 833-7958** • FAX (303) 322-7242
email: sales@geotechenv.com website: www.geotechenv.com