



Explosion Proof Control Module for Water Table Depression Pump™

Installation and Operation Manual

Table of Contents

DOCUMENTATION CONVENTIONS.....	2
Section 1: System Description.....	4
Function and Theory.....	4
System Components	4
Section 2: System Installation	11
Pump, Control Module, and Probe.....	11
Section 3: System Operation.....	13
System Pre-check	13
Section 4: System Maintenance	14
Probe maintenance	14
Section 5: System Troubleshooting	15
Section 6: System Specifications.....	18
Section 7: System Schematic.....	19
Section 8: Replacement Parts List.....	23
Appendix A: Winch Assembly.....	24
Electrical Data	26
Appendix B: Decontamination Procedures	27
The Warranty	33

DOCUMENTATION CONVENTIONS

This manual uses the following conventions to present information:



WARNING

An exclamation point icon indicates a **WARNING** of a situation or condition that could lead to personal injury or death. You should not proceed until you read and thoroughly understand the **WARNING** message.

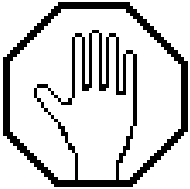

CAUTION

A raised hand icon indicates **CAUTION** information that relates to a situation or condition that could lead to equipment malfunction or damage. You should not proceed until you read and thoroughly understand the **CAUTION** message.

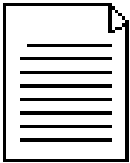

NOTE

A note icon indicates **NOTE** information. Notes provide additional or supplementary information about an activity or concept.

ATTENTION
READ THESE CAUTIONS & SUGGESTIONS BEFORE PROCEEDING



The Water Table Depression Pump is a sophisticated piece of equipment which must be installed, operated and maintained according to the procedures described in the system manual. Failure to follow these procedures or to observe the cautions included in the manual may result in personal injury and will void the Standard Equipment Limited Warranty.

Installation:

- Do not deploy the Water Table Depression Pump until the well has been developed by qualified personnel. Silt and grit can damage the pump and degrade its performance.
- Before deploying the system in the well, briefly test the pump by turning the control switch to HAND.

Operation:

- When adjusting the pump flow rate, reduce the rate of pump cycling as much as possible without going below the minimum flow rate recommended by the pumps manufacturer. Refer to pages 22 and 23 for data on flow rates. Geotech strongly suggests the use of a flow meter during this procedure.
- Never close the gate valve for more than 1-2 minutes while the pump is running.

Maintenance and Troubleshooting



DISCONNECT POWER BEFORE OPENING ANY ENCLOSURE.

- All maintenance and troubleshooting procedures must be carried out by qualified personnel only.
- Replace blown fuses with identical Geotech Environmental Equipment, Inc. parts unless instructed otherwise by the factory.
- Abraded or cut electrical cords should be replaced immediately.
- During your system troubleshooting, attempt only the procedures outlined in *Section 5: System Troubleshooting*.

Weekly Maintenance Checks:

- Confirm that the pump is cycling as slowly as possible while still maintaining the minimum flow rate recommended by the pump manufacturer.
- Check Start box and control module for accumulation of moisture.
- Disassemble and clean the probe in degreasing cleanser. Since the optimal interval between cleaning will depend on site-specific factors, more frequent probe maintenance may be required at some sites.

Monthly Maintenance Check:

- Take current draw or winding resistance readings to determine the health of the motor. Compare with pump/motor specifications in Appendices.
- If you require further assistance, please call our Customer Service Department at (800) 833-7958 or (303) 320-4764.

Section 1: System Description

Function and Theory

The Water Table Depression Pump (WTDP) is designed to facilitate the concentration and recovery of hydrocarbon. The system works by locally depressing the water table to create a “cone of depression” into which polluting hydrocarbon will flow with the surrounding groundwater.

Figure 1-1 compares recovery wells before and after a WTDP has been used to create a cone of depression. Note that the hydrocarbon layer becomes thicker after a cone of depression has been established. Static water level is the distance from the ground surface to the hydrocarbon/water interface. Drawdown is therefore the depth of the cone of depression. Radius of influence is the distance from the well center to the limit of the cone of depression.

Since the efficiency of hydrocarbon concentration and recovery is determined to a large extent by conditions in and around the recovery well, it is important that the well be drilled and developed under the supervision of a qualified hydro geologist. Well development is the process of removing fine sediments and grit from the well and reducing compaction of the surrounding earth. Properly carried out, well development procedures will increase the rate at which water and hydrocarbon can flow into the well. Other suggestions for proper recovery well maintenance and operation are:

1. Since there is a gradient of hydrocarbon dissolved in the water from the interface on down, the water pump intake should be positioned well below the hydrocarbon layer. Water samples should be tested on a regular basis. If hydrocarbon levels prove excessive, a water purification system can be used; contact Geotech Environmental Equipment, Inc. for further information.
2. Establish monitoring wells at different distances and directions from the recovery well. Monitor the cone of depression and any movements of the hydrocarbon plume.

System Components

The Water Table Depression Pumping system consists of a submersible or surface mounted pump, an explosion proof control module and an intrinsically safe level sensing probe which can distinguish between water and hydrocarbon.

Pump

Pump specifications are provided in *Section 6: System Specifications* of this manual. Refer to the appendices for detailed information on the pump.

Control Module

The control module is designed to turn the pump on when the level sensing probe is in water. The control module functions as shown in the logic diagram in Figure 1-2. The control circuits are housed in an explosion proof enclosure (Fig.3). Fuse sizes are given on the System Specification page. The probe receptacle is located on the bottom of the enclosure.

On the Control Module is the receptacle for the pump power cord plug. On the face of the Control Module is a power disconnect switch, a 3-Position Control Switch (HOA) and green and red indicator lights.

Control Switch

HAND - In the HAND position, the pump will run regardless of the condition of the probe.

OFF - The switch will disable the control circuit when in the OFF position. The pump will not run.

AUTO - When the switch is in the AUTO position, the probe controls the pump.

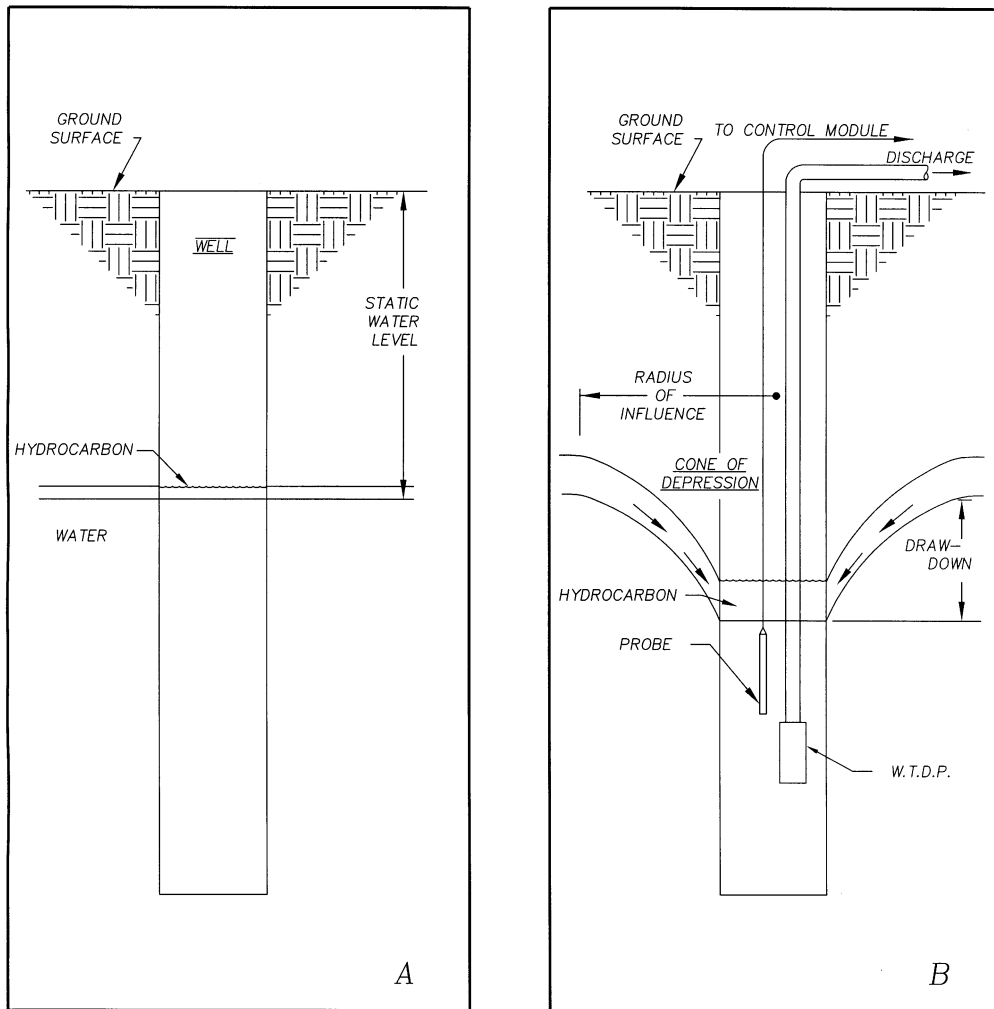

Figure 1-1: A hydrocarbon recovery well before (A) and after (B) installation of a Water Table Depression Pump

Indicator Lights

PUMP RUNNING (Green) - Indicates that power is being applied to the pump power cord receptacle.

OVERRIDE (Red) - Indicates that the pump has been shut off by the OVERRIDE float.

Positioning the Level Sensing Probe

On the WTDP level sensing probe, the cable is marked every foot with a 5 digit number. To position the probe at a predetermined depth in the well, simply lower the probe until the desired depth in feet is indicated by the last 2 digits of the number on the cable.

Density Actuated Level Sensing Probe

The density actuated probe (Fig. 4) has 2 floats and contains three separate sensors referred to as HI, LO, and OVERRIDE. These sensors are triggered by float activated reed switches, and control the status of the pump. The floats will rise in water but not in hydrocarbon. This probe is primarily used in water that has a high iron or salt content.

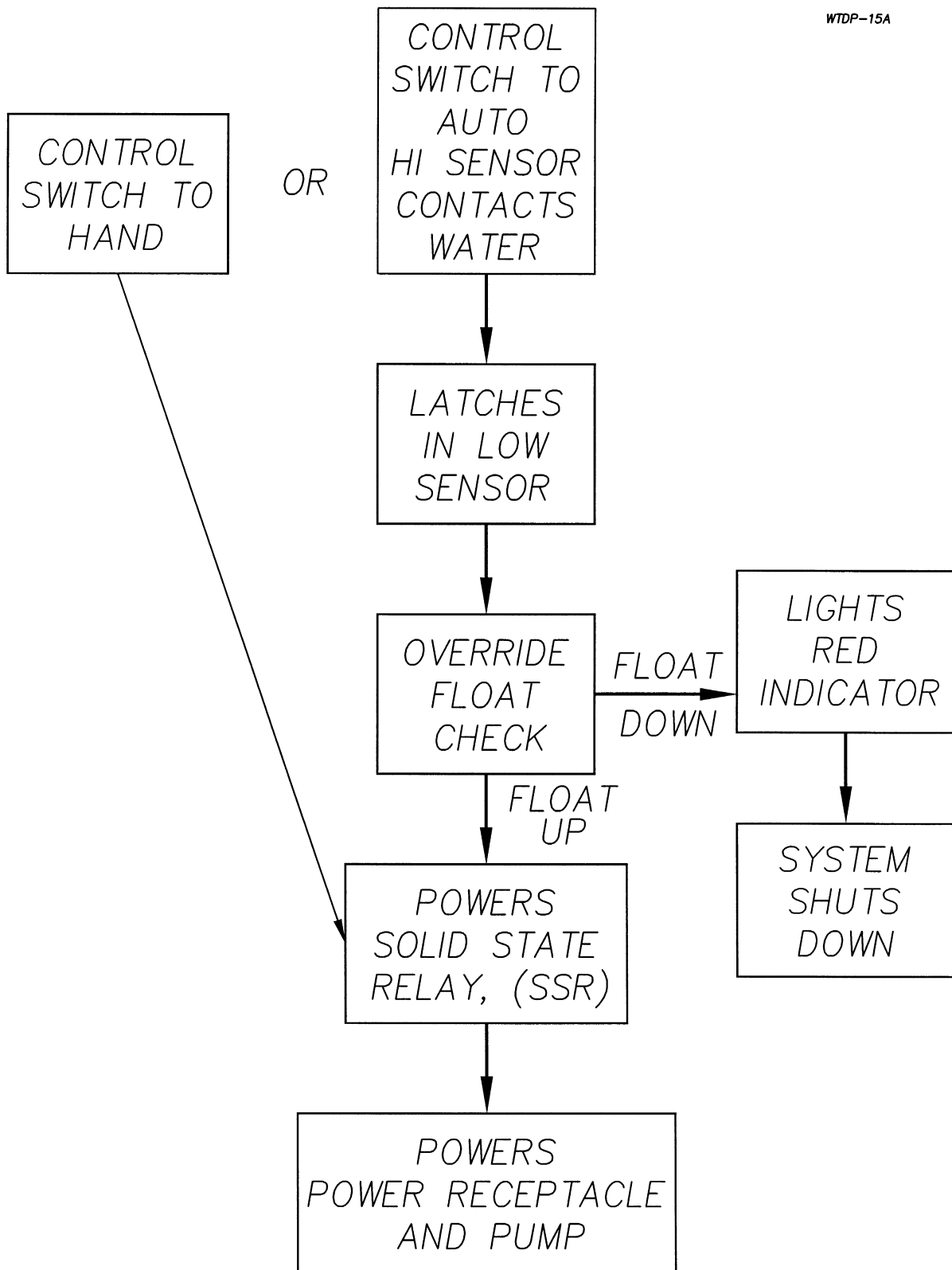

Figure 1-2: Logic Diagram for Water Table Depression Pump



Figure 1-3: The Water Table Depression Pump Control Module (old version)

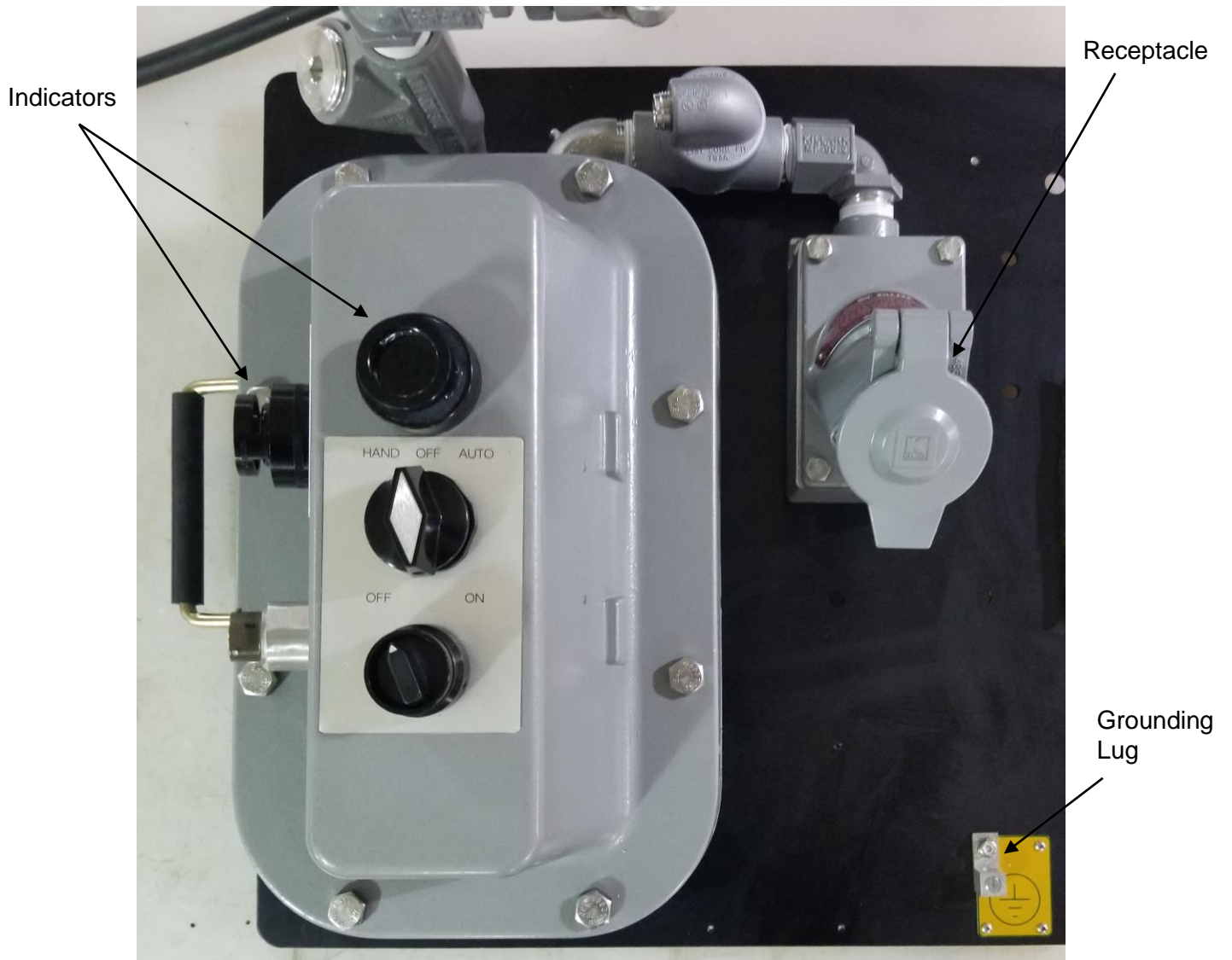

Figure 1-4: The Water Table Depression Pump Control Module (New version)

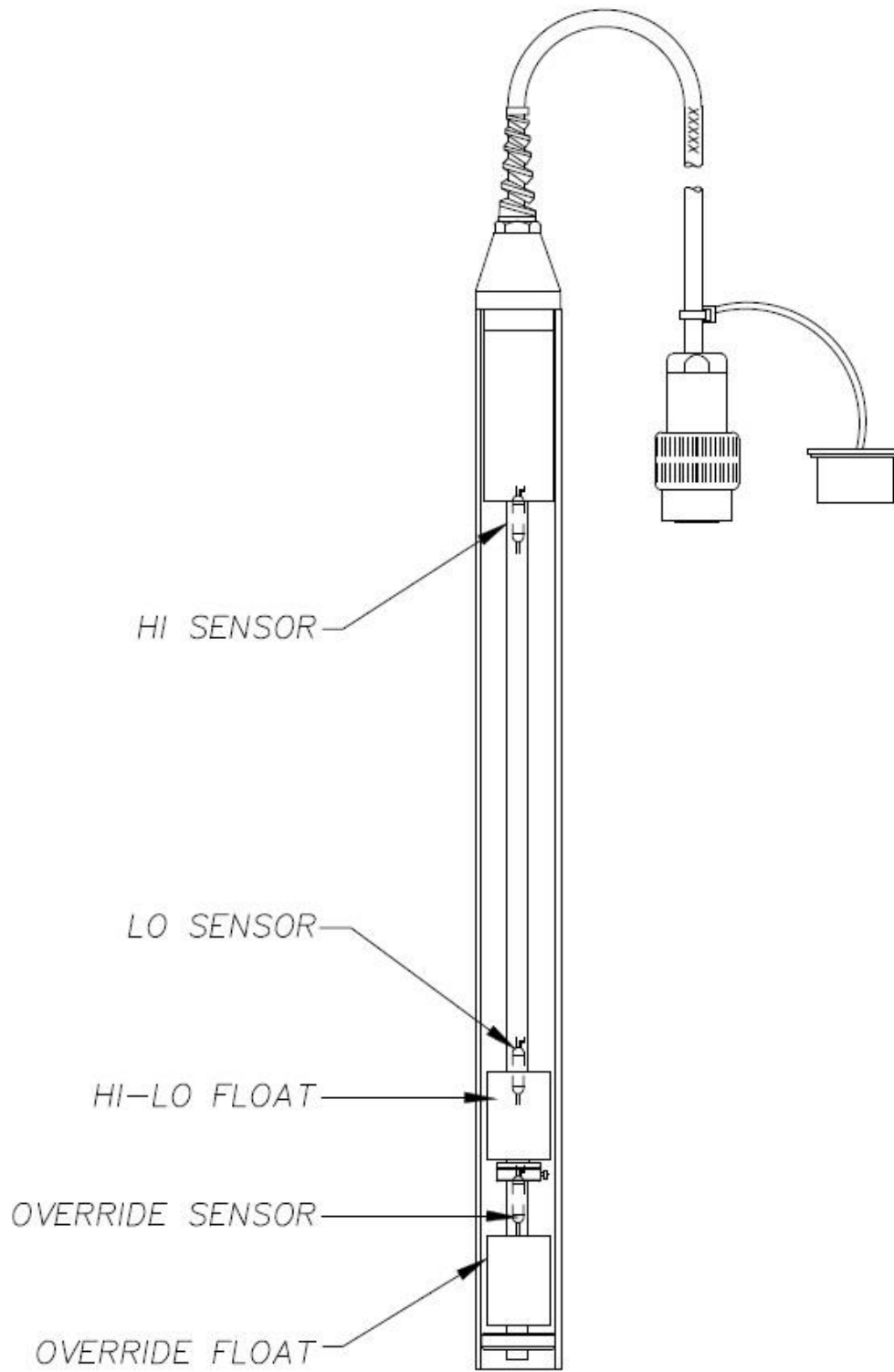

Figure 1-5: Water Table Depression Pump Density Probe

When the HI-LO and OVERRIDE floats rise and fall with the water level and reach a sensor, the following sequence will take place:

1. A magnet imbedded in the float(s) will activate the HI, LO, or OVERRIDE sensor(s). The OVERRIDE sensor must be OPEN in order for the pump to run.
2. The HI and LO sensors are used to start and stop the pump at two different levels. To start the pump, the HI-LO float must be activating the HI sensor. The pump will then run until the water level falls below the LO sensor. This differential level system prevents the rapid on and off cycling of the pump that would occur if the pump was started and stopped at the same level. This rapid cycling would destroy the pump motor in a short time.

In addition to the HI and LO sensors, the OVERRIDE sensor acts as a redundant shut off in case the HI-LO float becomes caught. An override condition occurs when the HI-LO float fails to sink as the water level falls below the LO sensor. As the pump continues to run, the water level will fall further causing the OVERRIDE float to drop. The following sequence then occurs:

- The dropped float activates the OVERRIDE sensor.
- The pump stops running.
- The red OVERRIDE indicator will be illuminated and the pump will shut down.
- The system will remain in the override condition until the water table rises and de-activates the OVERRIDE sensor.
- The pump will turn on once the HI-LO float activates the HI sensor.



If the system continually goes into override, refer to *Section 5: System Troubleshooting*.

Section 2: System Installation

Refer to System Pre-Check in Section 3: System Operation before installing Water Table Depression Pump.

Pump, Control Module, and Probe

1. Lower the pump (submersible systems) or intake (surface mounted systems) into the well. Submersible pumps are equipped with a winch assembly when purchased separately. Do not suspend the pump by its power cord or discharge hose. Suspend the intake as far below the hydrocarbon/water interface as possible without resting it directly on the well bottom; this prevents debris from reaching the pump intake.



The system should be purged if free hydrocarbon is present in the well at deployment. To do this, place the output hose in a suitable container and run the pump on HAND until the water runs clear. Dispose of purged hydrocarbon according to local codes.

2. Deploy the control module adjacent to the well. Mount vertically to reduce the possibility of intrusion by rain. If using a vault, mount the control module as far above the well head as possible. This will reduce the possibility of damage to the control module should the vault become flooded. See Figure 2-1 for a typical vault layout.
3. Attach the connector to the receptacle. Note that the bayonet connector and receptacle are slotted. Push the cable connector onto the receptacle and turn it clockwise until it locks.
4. Confirm that the output hose of the pump is connected to suitable piping or to a proper runoff. Check local regulations.
5. Open the gate valve completely by turning it counterclockwise.
6. Attach the pump power cord to the control module.
7. Turn the control switch to OFF. Confirm that the system power cord is plugged into a suitable power source and that a ground fault interrupter has been installed at the service.
8. Turn the power disconnect switch to the ON position. Turn the control switch to AUTO.
9. Lower the probe into the well. The pump will start when water contacts the HI sensor.
10. Establish a pumping level and throttle down the outflow with the gate valve. Reduce the rate of pump cycling as far as possible without going below the minimum flow rate recommended by the pumps manufacturer. Ideally, the pump should be made to run continuously.
11. With reference to the pump curves, run the pump until the water table is lowered one foot (30.5cm). Use a flow meter to obtain a pumping rate. If a flow meter is not available, record the time required to fill a container of known volume. Determine how much pumping is required to obtain one foot of depression.
12. Lower the probe to the desired level of drawdown. Use the marks on the probe cable to determine depth.



The pump intake should be positioned at least 5' (1.5 m) below the level of drawdown. This will minimize intake of contaminated water.

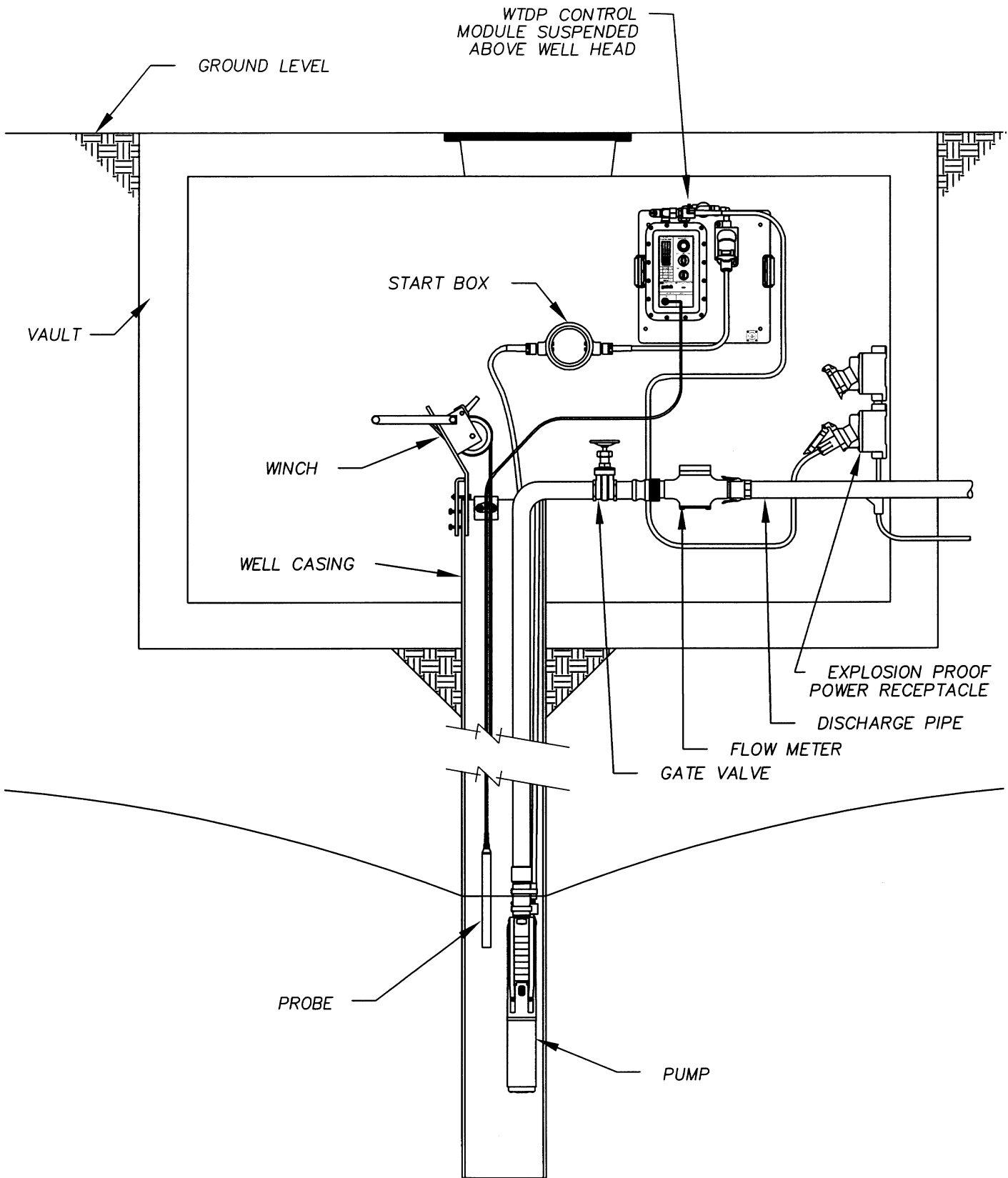

Figure 2-1: Water Table Depression Pump Deployed in Vault

Section 3: System Operation

System Pre-check

Before the Water Table Depression Pump is deployed in the well, perform the following pre-check to familiarize yourself with the controls and to confirm correct operation.



Carry out this procedure in a non-hazardous location.

1. Obtain a bucket of water about 12" (30.5 cm) deep for testing purposes.
2. Turn the control switch to the OFF position and plug the control module power cord into a suitable power source.
3. Plug the probe cable connector into the 8-pin receptacle on the control module. Note that the cable connector and receptacle are slotted. Push the cable connector onto its receptacle and turn it clockwise until it catches.
4. Attach the pump power cord to the control module.
5. Turn the control switch to HAND. The green indicator should light when power is applied to the pump.



Do not run the pump dry for more than a few seconds.

6. Return the control switch to OFF. Put the probe in the bucket of water.
7. Turn the control switch to AUTO. The green indicator should light, meaning that the pump is running and being controlled by the probe.
8. With the control switch still in the AUTO position, check the OVERRIDE function as follows:
9. Remove the probe from the bucket of water. Obtain a thin piece of wire and insert it through the probe shell to hold the bottom float in the down position. Turn the probe upside down in air. The red indicator will turn on. This simulates the pump being shut off due to low water level (caused by a probe or control circuit malfunction).
10. Return the control switch to the OFF position. The system is now ready for deployment in the well.

Section 4: System Maintenance

Probe maintenance

A schedule of routine maintenance tasks is provided in Figure 3-1 below.

Probe maintenance consists of periodic rinsing in clean gasoline and/or hot water. This procedure will prevent fouling which could lead to probe failure.

WATER TABLE DEPRESSION PUMP SYSTEM FREQUENCY OF MAINTENANCE TASKS / QUARTERLY CALENDAR						
TASK	WEEK 1	WEEK 2	WEEK 3	WEEK 4	WEEK 5	WEEK 6
CHECK FLOW RATE TO ENSURE MINIMUM CYCLING FREQUENCY	●	●	●	●	●	●
REMOVE COVER FROM PROBE AND CLEAN FLOATS/CONDUCTIVITY SENSORS	●	●	●	●	●	●
CHECK START BOX FOR MOISTURE ACCUMULATION	●	●	●	●	●	●
TAKE CURRENT DRAW READINGS AND COMPARE WITH APPROPRIATE MOTOR SPEC. IN APPENDIX	●	●	●	●	●	●
INSPECT HOSES AND WIRES FOR CRACKS, CUTS, OR ABRASIONS	●	●	●	●	●	●
WEEK 1	●	●	●	●	●	●
WEEK 2	●	●	●	●	●	●
WEEK 3	●	●	●	●	●	●
WEEK 4	●	●	●	●	●	●
WEEK 5	●	●	●	●	●	●
WEEK 6	●	●	●	●	●	●
WEEK 7	●	●	●	●	●	●
WEEK 8	●	●	●	●	●	●
WEEK 9	●	●	●	●	●	●
WEEK 10	●	●	●	●	●	●
WEEK 11	●	●	●	●	●	●
WEEK 12	●	●	●	●	●	●

Figure 3-1: Routine Maintenance Schedule

Section 5: System Troubleshooting



WHEN WORKING IN HAZARDOUS AREAS, DISCONNECT POWER BEFORE OPENING ANY ENCLOSURE.

These procedures are meant to be carried out by personnel qualified to work on electrical circuitry. If in doubt, obtain the services of a qualified electrician.

Required tools and spare parts include a multi-meter, a screwdriver, jumper wires and spare fuses. Refer to *Section 6: System Specifications* for fuse sizes.

PROBLEM: Pump does not run on Hand or Auto

Solution:

1. Check for power to the control module. If there is no power present check the branch circuit.
2. Check for a blown fuses (F1 and F2 on 115 VAC units, F1, F2 and F3 on 230 VAC units) in the control circuit (see System Schematic). If the fuse is blown, replace it only once. If the fuse blows again, further troubleshooting is necessary.

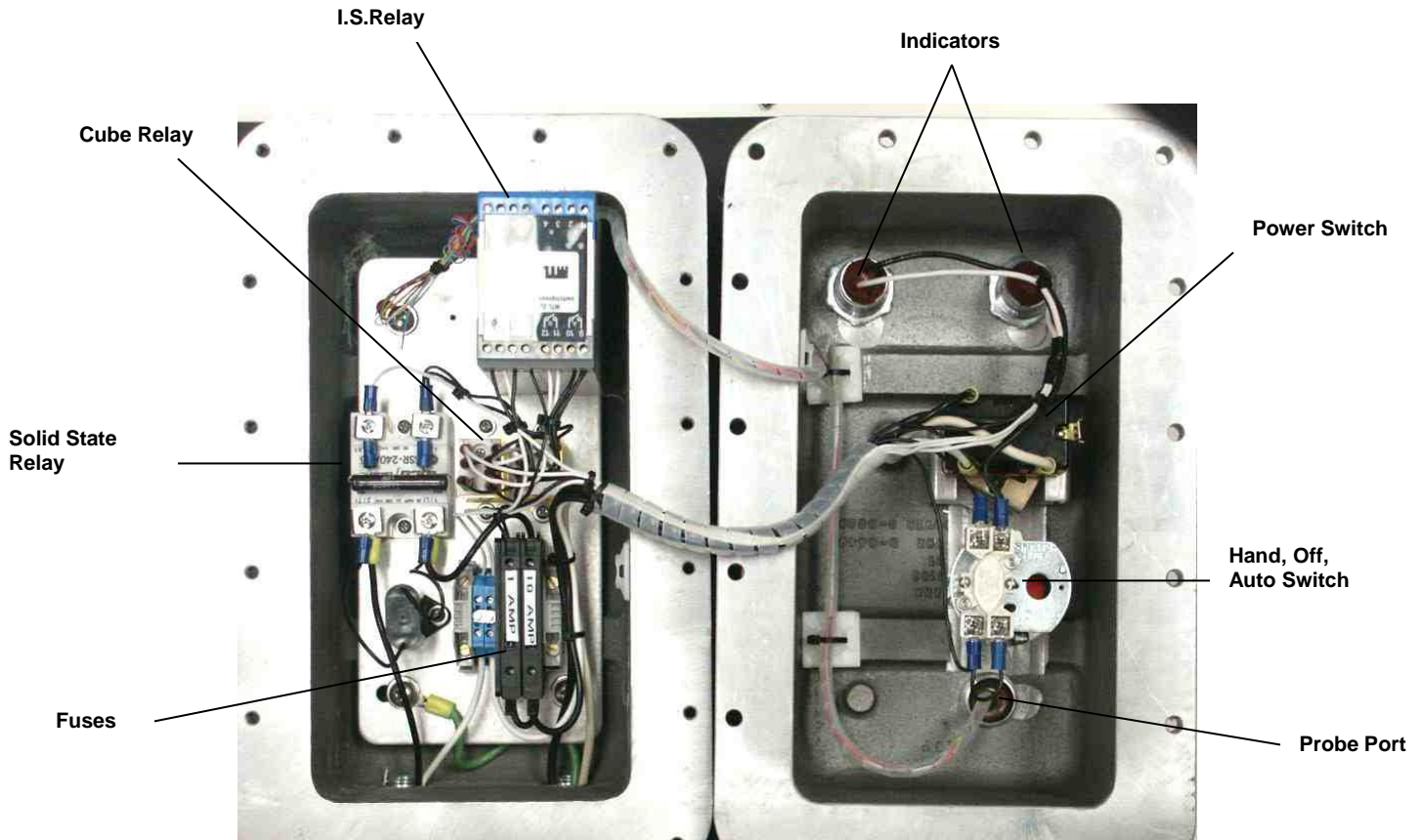

Figure 5-1: Internal Components (old)

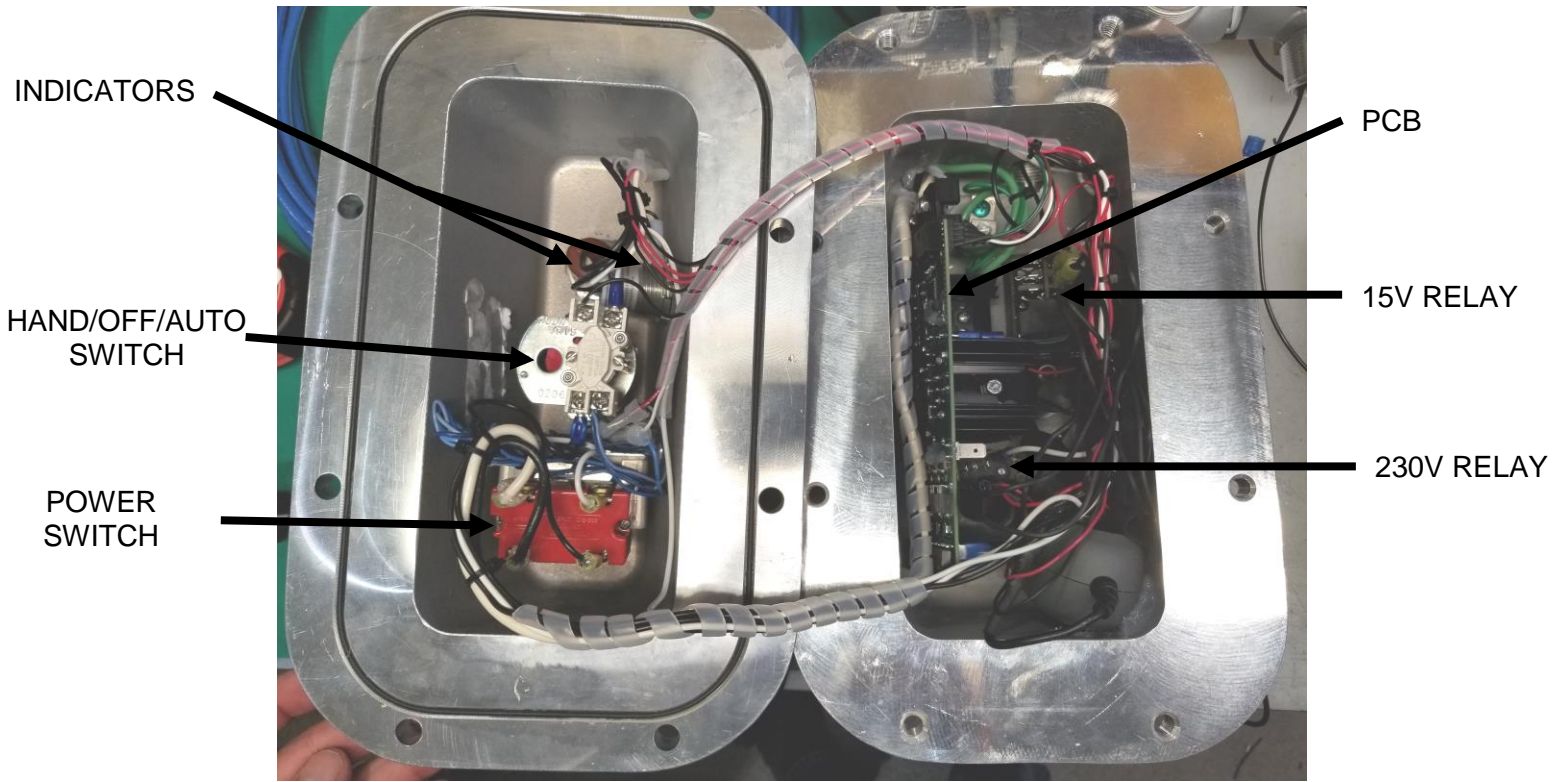
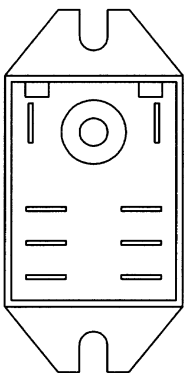
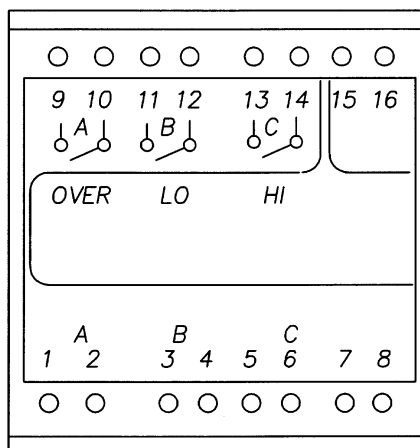

Figure 5-2: Internal Components (New)

3. Check main power switch for failure. With the power disconnect from unit, measure for switch closure using a multi-meter set on resistance. Turn the switch to the on position and measure between screw terminals on the same side of the switch. Measurement should be less than 10 ohms. Repeat to check the other side of the switch.
4. Check to make sure the hand-off-auto switch is operating properly. In the off position, an "open line" condition should be present between all screw terminals. Turn the switch to hand. Less than 10 ohms should be seen between the "open" side of the contacts and infinite ohms should be measured between the "closed" contacts. Turn the switch to auto. The exact opposite should be measured; Infinite resistance between the "open" contacts and less than 10 ohms for the "closed" contacts.



CUBE RELAY



**I.S. RELAY
(Old version only)**

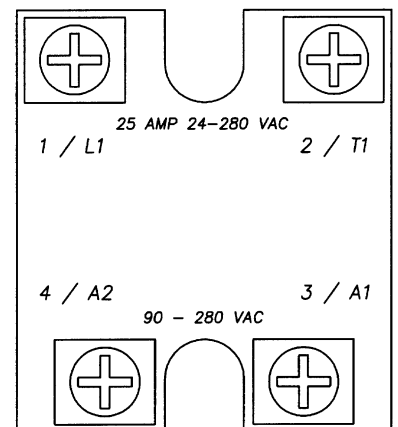

SOLID STATE RELAY

Figure 5-3: Control Relays

5. Check operation of the solid state relay (SSR). Add power to unit. Turn hand-off-auto switch to hand. Using a multi-meter, set it to AC volts and measure the voltage between A1 and A2. The reading should match supply voltage.

PROBLEM: Pump Runs on Hand but not on Auto.

Solutions:

1. Apply power to the control module. Turn the control switch to the AUTO position. Measure the voltage on I.S. relay pins 15 and 16. The voltage should match supply voltage. If voltage is not present, check the control switch and its wiring.
2. If voltage is present, disconnect the probe. Insert the ends of a jumper wire into pins 1 and 2 on the I.S. relay. The LED with the corresponding letter should illuminate. Repeat steps for pins 3 and 4, and 5 and 6. If LED's don't illuminate, replace I.S. relay.
3. If all the LED's illuminate, turn the power off. Measure continuity from probe port to I.S. relay. Color to pin code is as follows:

Pin A – White
 Pin B – Black
 Pin C – Yellow
 Pin D – Blue (Not Used)
 Pin E – Orange
 Pin F – Red
 Pin G – No Wire
 Pin H - Green

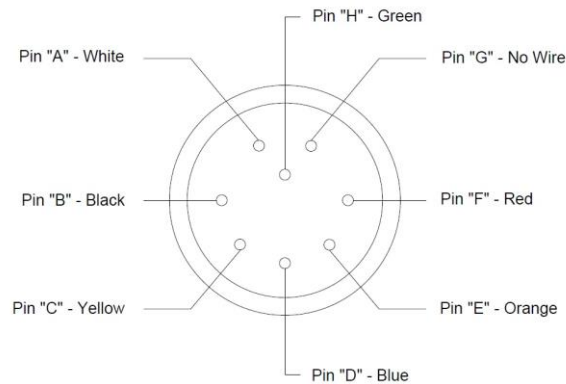

Figure 5-4: Pin Connections

If continuity is not found on all 6 pins to their respective wires, replace probe port and wires.

4. If continuity check passes, reconnect probe. Remove holding pin on probe bottom, then probe bottom and then the probe housing. Turn on the power and raise water OVERRIDE float. The red Indicator on box's cover should go out and the "A" LED on the I.S. relay should also go out. If this does not happen go to next step. While holding the OVERRIDE float, raise the water level float halfway. The "B" LED should now illuminate and the right hand see through cube relay should energize (this can be verified visually). If the LED does not illuminate go to next step. It might be necessary to raise and lower the float several times to ensure that the relay is functioning correctly. Then raise the float to the top of its travel. The "C" LED should now illuminate and the left hand see through cube relay should now energize. If the LED does not illuminate go to next step. If movement cannot be seen on either relay, turn probe upside down and measure AC voltage across pins 13 and 14. Voltage should match supply voltage. If voltage is present replace cube relay(s).
5. Disconnect probe and check reed switches. With the OVERRIDE float down, measure conductivity from pins E and H. Move the water level float to half way and measure between pins C and B. Move the water level float all the way up and measure between pins C and A. If any of these measurements fail, replace probe.

If problem is not solved through these steps or difficulties arise, call Geotech Environmental Equipment Inc. at 1-800-833-7958 and speak with the troubleshooting department.

Section 6: System Specifications

System Type

Deep Well Submersible

Shallow Well Submersible

Surface Mounted

Pump Model No. _____

Power Requirements

_____ HP

_____ Voltage

_____ Phase

_____ Amps

Fuses

_____ F1, _____ F2, _____ F3

Lengths & Dimensions:

_____ inch Pump/Intake Diameter

_____ ft. Sensor Cable

_____ ft. Start Cord

_____ ft. Intake Hose

_____ ft. Output Hose

Serial No. _____

P.I.D No. _____

Inspected By: _____

Section 7: System Schematic

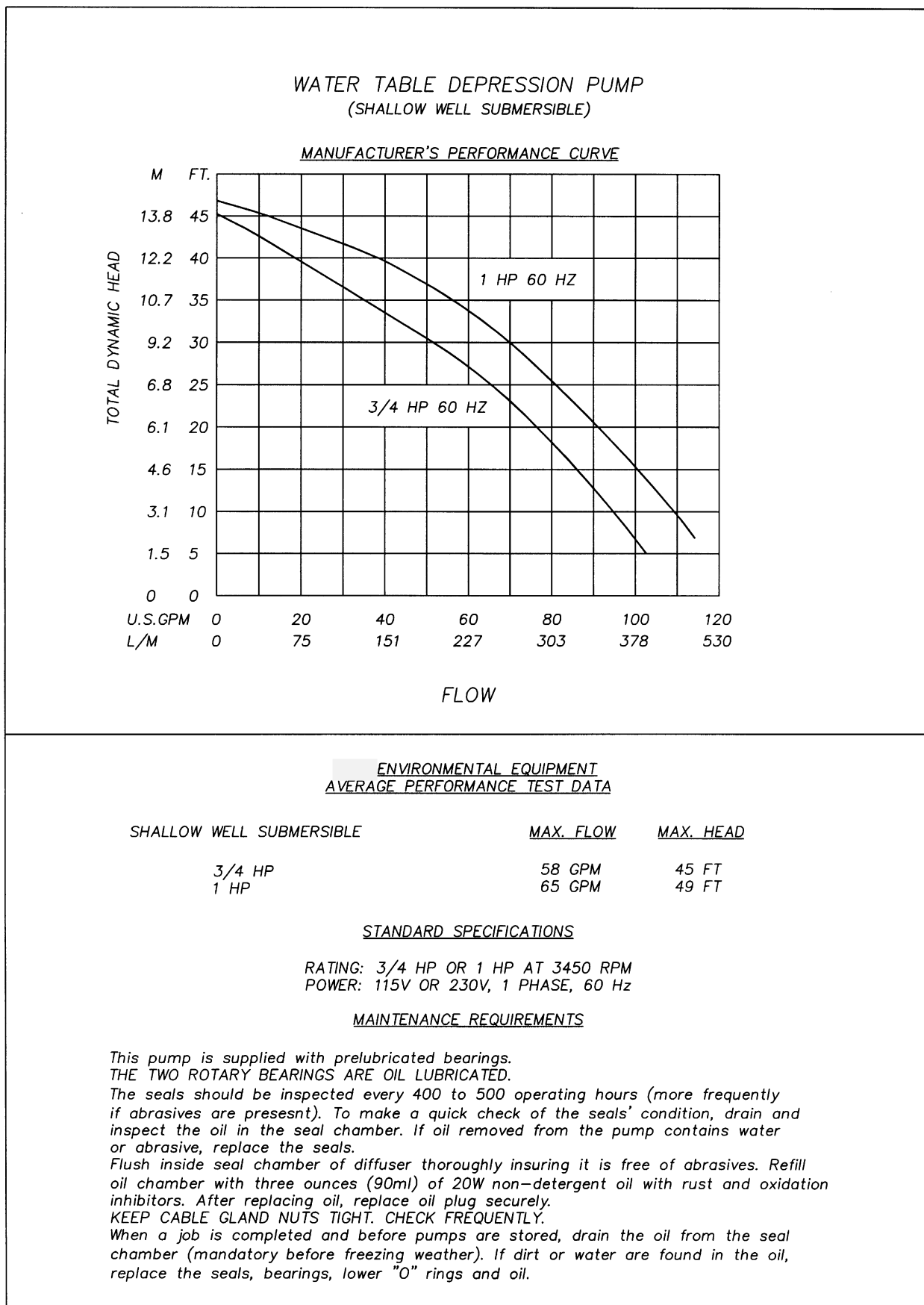
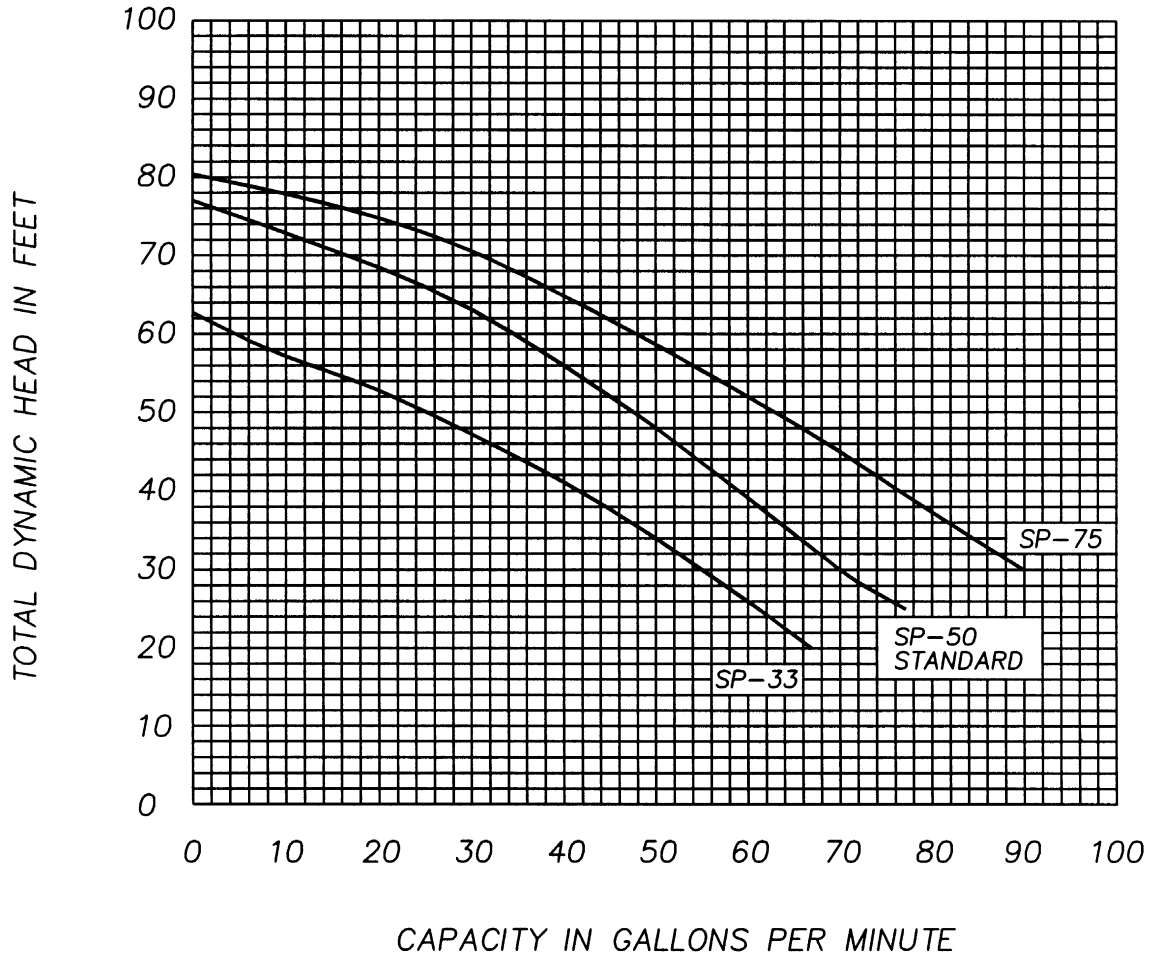

Figure 7-1: WTDP Performance Curves

SURFACE MOUNTED WATER TABLE DEPRESSION PUMP

TYPE SP SELF-PRIMING CAST IRON CENTRIFUGAL PUMPS

MANUFACTURER'S PERFORMANCE CURVE



ENVIRONMENTAL EQUIPMENT

AVERAGE PERFORMANCE TEST DATA

	<u>MAX. FLOW</u>	<u>MAX. HEAD</u>
SP-50	52 GPM	72 FT

NOTE:

MAXIMUM SUCTION LIFT 25 FEET (STATIC PLUS FRICTION)
BASE ON WATER AT 70°F.

Figure 7-2: Surface Mounted Water Table Depression Pump

REF. DWG: CE-20

2031057	
RESISTANCES AT MOTOR	
RED to YELLOW	6.8 ohm
RED to BLACK	7.8 ohm
BLACK to YELLOW	.97 ohm
CURRENT AT MOTOR	
RUNNING CURRENT	11.0 AMP
LOCK ROTOR CURRENT	38.3 AMP

REF. DWG: CE-18

2031043	
RESISTANCES AT MOTOR	
RED to YELLOW	9.3 ohm
RED to BLACK	10.4 ohm
BLACK to YELLOW	1.2 ohm
CURRENT AT MOTOR	
RUNNING CURRENT	9.5 AMP
LOCK ROTOR CURRENT	28.3 AMP

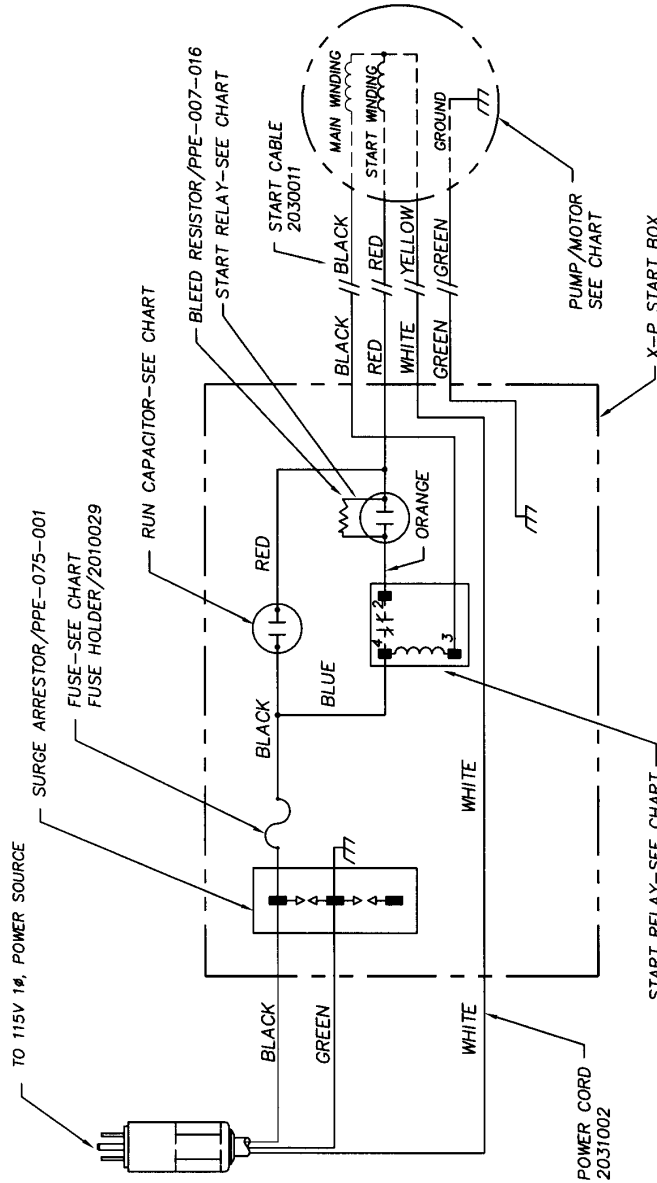

START BOX SCHEMATIC FOR 115VAC, 60Hz, SHALLOW WELL SUBMERSIBLE WATER PUMPS

ASSEMBLY #	PUMP/MOTOR	START CAPACITOR	START RELAY	FUSE SIZE
2032031	3/4HP, 230V, 60HZ, 1PH.	108-130uF, 220-250 VAC	3ARR3 MARS 551	ABC 8 AMP
	PPP-005-023	PPE-008-114	PPE-014-106	PPE-011-015
2032095	1HP, 230V, 60HZ, 1PH.	108-130uF, 220-250 VAC	3ARR3 MARS 551	ABC 8 AMP
	PPP-005-045	PPE-008-114	PPE-014-106	PPE-011-015
2032029	2HP, 230V, 60HZ, 1PH.	189-227uF, 250VAC	3ARR3 MARS 551	ABC 20 AMP
	PPP-005-041	PPE-008-116	PPE-014-106	PPE-011-014

Figure 7-3: Start Box for 115V, 60Hz, Shallow Well Submersible Water Pumps

REF. DRAWING: CE-16

2032029	
RESISTANCES AT MOTOR	
RED to YELLOW	4.2 ohm
RED to BLACK	5.8 ohm
BLACK to YELLOW	1.6 ohm
CURRENT AT MOTOR	
RUNNING CURRENT	12.8 AMP
LOCK ROTOR CURRENT	51.0 AMP

REF. DRAWING: CE-19

2032095	
RESISTANCES AT MOTOR	
RED to YELLOW	9.0 ohm
RED to BLACK	9.0 ohm
BLACK to YELLOW	3.9 ohm
CURRENT AT MOTOR	
RUNNING CURRENT	6.7 AMP
LOCK ROTOR CURRENT	23.1 AMP

REF. DRAWING: CE-40

2032031	
RESISTANCES AT MOTOR	
RED to YELLOW	9.0 ohm
RED to BLACK	8.8 ohm
BLACK to YELLOW	4.8 ohm
CURRENT AT MOTOR	
RUNNING CURRENT	5.8 AMP
LOCK ROTOR CURRENT	16.1 AMP

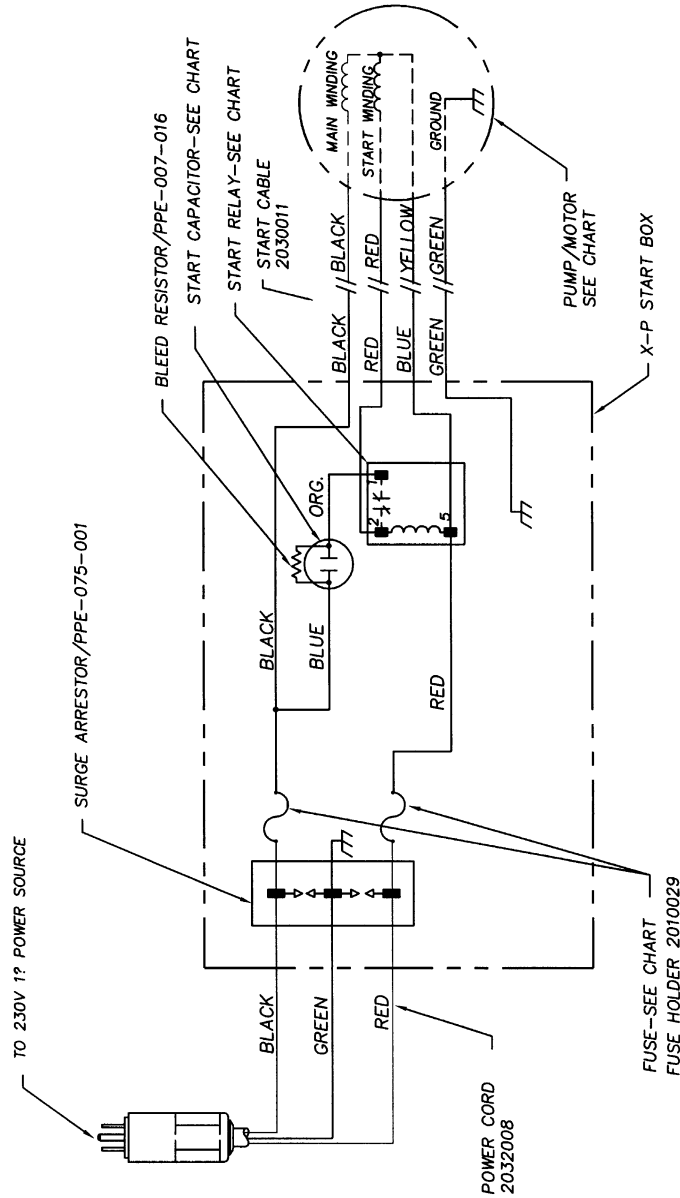

START BOX SCHEMATIC FOR 230VAC, 60Hz, SHALLOW WELL SUBMERSIBLE WATER PUMPS

ASSEMBLY #	PUMP/MOTOR	START CAPACITOR	START RELAY	FUSE SIZE
2032031	3/4HP, 230V, 60HZ, 1PH. PPP-005-023	108-130uF, 220-250 VAC PPE-008-114	3ARR3 MARS 551 PPE-014-106	ABC 8 AMP PPE-011-015
	1HP, 230V, 60HZ, 1PH. PPP-005-045	108-130uF, 220-250 VAC PPE-008-114	3ARR3 MARS 551 PPE-014-106	ABC 8 AMP PPE-011-015
2032029	2HP, 230V, 60HZ, 1PH. PPP-005-041	189-227uF, 250VAC PPE-008-116	3ARR3 MARS 551 PPE-014-106	ABC 20 AMP PPE-011-014

Figure 7-4: Start Start Box for 230V, 60Hz, Shallow Well Submersible Water Pumps

Section 8: Replacement Parts List

Description	Part #
WTDP XP Control Module	
WTDP,XP,CONTROL PANEL,115V	56190005
WTDP,XP,CONTROL PANEL,230V	56190006
PLUG,115V,EP	PPE017001
PLUG,230V,EP	PPE017003
RECEPTACLE,POWER,115V,EP	PPE046003
RECEPTACLE,POWER,230V,EP	PPE046005
CONTROL RECEPTACLE,8 SOCKET, ASSY,POTTED	26020024
Probe	
PROBE,SM.DIA.,DENS,50',2005	56120014
Spare Parts	
FUSE,20A,250V,NON DLY,ABC	PPE011014
FUSE,8A,250V,NON-DELAY	PPE011015
FUSE,1A,250V,SLO-BLO	PPE011026
MANUAL,WTDP 115/230V,60HZ	ORS999003062
LIGHT BULB,IND,12V, SLIDE SDFS CONTROL	PPE102003
SWITCH,OPER,3 POS,EP	PPE015025
RELAY,230V,10AMP,DPDT,RCT	PPE014091
RELAY,12VDC,30A,DPDT	12050521
ASSY,WINCH,STD DUTY,71FT 1000LB MAX	2020005

Appendix A: Winch Assembly

Mount the winch on the well casing as shown on the next page. Attach the winch cable to the lifting lug on the pump. Carefully lower the pump into the well and suspend at the desired level.

The standard winch cable supplied with Geotech pumping systems has a rated break strength of 2000 lbs. Using the recommended design ratio of 1/5, the rated break strength gives a maximum hanging weight of 400 lb.

Because each application is different, it is impossible for us to anticipate the exact hanging weight of your system. Hanging weight is the sum of pump weight, the weight of all discharge piping and the weight of any water trapped inside the piping. Although it is unlikely that you will exceed the 400 lb. maximum, we highly recommend that you take the time to calculate the hanging weight of your system before deployment.

Use the following procedure to calculate hanging weight.

1. Weigh your pump assembly including the intake and any attached probes.
2. The weight of discharge piping can be calculated by weighing a sample length and multiplying by the number of feet suspended in the well. For example, 1-1/2" rubber transfer hose (Geotech Part #PPP-001-013) weighs approximately 1 lb. per foot. Therefore 100' of this hose will weigh 100 lb.
3. The weight of water in the discharge piping can be estimated by calculating the volume of water in the piping and then converting volume to weight as follows:

$$\text{Volume (in } 3) = 3.14 \times (\text{inside radius of pipe})^2 \times \text{length of pipe}$$

$$\text{Gallons} = 0.00433 \times \text{Volume (in} 3)$$

$$\text{Pounds of water} = 8.325 \times \text{Gallons}$$

4. Find the sum of pump weight, piping weight and water weight. This sum will provide a close approximation of total hanging weight.

If total hanging weight approaches or exceeds 400 lb., Geotech can provide an optional winch cable with an increased break strength rating.

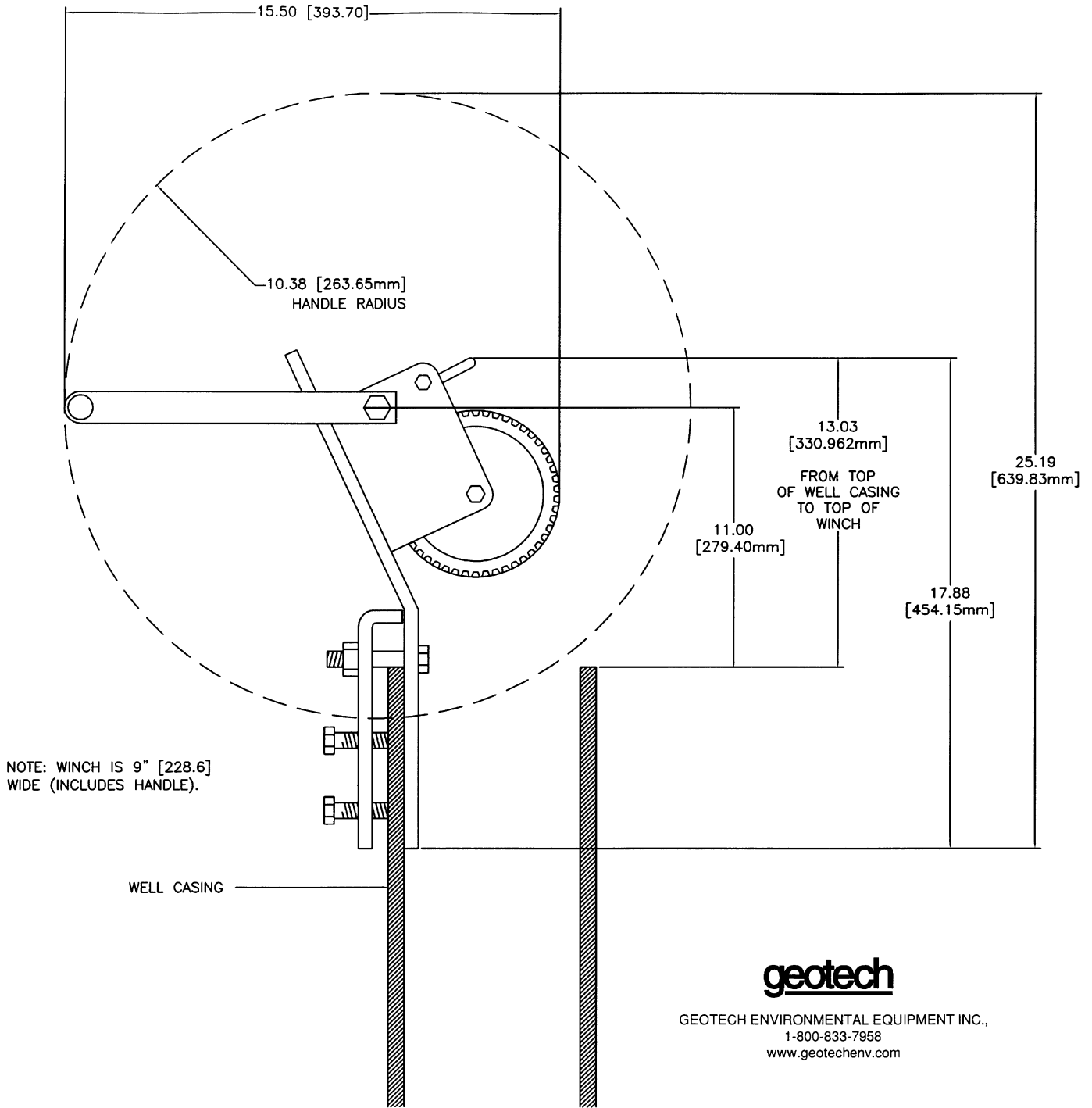

Electrical Data

HORSEPOWER	PHASE	VOLTS	MAX. RATED CURRENT AMPS			MAX KW INPUT	WINDING RESISTANCE IN OHMS ± 5% NOMINAL			BREAKER RATED AMPSE+	CABLE		MIN GEN SIZE (KW)	
			NO LOAD	FULL LOAD	LOCK'D ROTOR		WHITE BLACK	WHITE RED	RED BLACK		SIZE AWG	MAX LENG. FT**		
3/4	1	115	8.3	10.4	33.5	1.0	1.2	9.3	10.4	+20.0	14/4	107.	2.0	
	1	230	4.0	5.2	21.9		5.0	12.0	12.0			6.5		275.
	3	230	2.2	3.2	17.3		6.3	6.3	6.3			3.6		596.
	3	460	.9	1.3	8.5		25.5	25.5	25.5			2.0		2210.
3	575	.6	1.0	7.7	31.0	31.0	31.0	1.5	3460.					
1	1	115	12.1	13.1	39.5	1.2	.90	7.4	8.3	+20.0	14/4	83.	2.5	
	1	230	6.0	7.1	22.5		2.90	8.4	8.4			8.0		197.
	3	230	1.65	2.7	19.5		5.0	5.0	5.0			4.5		455.
	3	460	.8	1.6	9.8		20.0	20.0	20.0			2.0		1824.
2	1	115	13.6	25.3	88.7	2.6	.4	1.1	1.5	2.6	12/4	127.	4.0	
	1	230	6.9	12.8	51.0		1.6	4.2	5.8			13.0		197.
2 1/2	1	230	6.6	10.6	41.	2.3	2.0	2.0	2.0	13.0		212.	5.0	
	3	230	4.5	6.8	49.2		2.0	2.0	2.0			9.0		329.
	3	460	2.4	4.1	31.3		8.0	8.0	8.0			4.5		1315.
	3	575	1.6	3.2	26.1		10.4	10.4	10.4			3.6		2080.
2 3/4	1	230	4.0	12.5	52.6	2.5	1.6	4.2	5.8	13.0		307	7.0	
3 1/2	1	230	10.5	18.4	90.1	3.8	.85	2.2	2.2	22.0		195.	7.5	
5	1	230	10.1	17.9	82.	5.2	.85	.85	.85	22.0		198.	15.0	
	3	230	8.	15.5	87.8		.85	.85	.85			18.0		220.
	3	460	4.2	7.8	43.9		3.60	3.60	3.60			9.0		925.
	3	575	3.1	6.2	35.1		5.20	3.60	5.20			7.2		898.
5 2 STAGE	3	230	8.5	15.2	87.8	5.2	.85	.85	.85	18.0		220.		
	3	460	4.2	7.6	43.9		3.60	3.60	3.60			9.0		925.
	3	575	3.1	6.1	35.1		5.20	3.60	5.20			7.2		898.
10 HV	3	230	13.0	30.0	208.0	10.0	.30	.30	.30	34.0	8/3/3* 12/4	324.	30.0	
	3	460	6.5	15.0	104.0		1.14	1.14	1.14			18.0		344.
	3	575	5.2	12.0	83.0		2.0	2.0	2.0			13.6		467.
10 HH	3	230	13.0	28.6	208.0	10.0	.30	.30	.30	34.0	8/3/3* 12/4	363.		
	3	460	6.5	14.3	104.0		1.14	1.14	1.14			18.0		362.
	3	575	5.2	11.5	83.0		2.0	2.0	2.0			13.6		560.
15 HV	3	230	14.4	39.0	288.0	14.0	.21	.21	.21	45.0	8/3/3* 12/4	266.	40.0	
	3	460	7.2	19.5	144.0		.75	.75	.75			22.0		420.
	3	575	5.8	15.6	110.0		1.21	1.21	1.21			18.0		658.
15 HH	3	230	14.4	36.8	288.0	14.0	.21	.21	.21	45.0	8/3/3* 12/4	268.		
	3	460	7.2	18.4	144.0		.75	.75	.75			22.0		445.
	3	575	5.8	14.7	110.0		1.21	1.21	1.21			18.0		698.
25 HV & HH	3	230	22.8	65.8	464.0	25.0	.37	.37	.37	80.0	6/3/3*	322.	60.0	
	3	460	11.4	32.9	232.0		.10	.10	.10			40.0		522.
	3	575	9.1	26.3	185.0		.55	.55	.55			30.0		812.
50 HV & HH	3	460	19.7	56.0	360.	45.0	.19	.19	.19	60.0	6/3/3*	336.	100.0	
	3	575	15.8	44.6	288.		.29	.29	.29			50.0		533.

Appendix B: Decontamination Procedures

Some common decontamination solutions are listed below along with the contaminants they are effective against:

<u>Solution</u>	<u>Effective Against</u>
Water	Short-chain hydrocarbons, inorganic compounds, salts, some organic acids, other polar compounds.
Dilute Acids	Basic (caustic or alkaline) compounds, amines, hydrazines.
Dilute Bases	Acidic compounds, phenols thiols, some nitro- and sulfonic compounds.
Organic solvents	Non-polar compounds (such as some organic compounds)

The use of organic solvents is not recommended because:

- 1) organic solvents can permeate and/or degrade the protective clothing and
- 2) they are generally toxic and may result in unnecessary employee exposure to hazardous chemicals.

When in doubt, use a dish washing liquid detergent. As a decontamination solution, it is readily available, is the safest of all the above, and is usually strong enough if used generously.

The use of steam can also be effective for decontamination. A water-lazer (pressurized water) is exceptionally valuable.

The following substances are noted for their particular efficiency in removing certain contaminants or for decontaminating certain types of equipment.

<u>Solution</u>	<u>Effective Against</u>
Penetone	PCB Contamination (since penetone may also remove paint, it is a good idea to spot-test before use)
Phosphate free detergent	Contaminated pumps
Ivory liquid	Oils
Diluted HTH	Cyanides
Radiac	Low level radioactivity
Isopropanol	Biological agents (should not be used on rubber products since it will break down rubber)
Hexane	Certain types of lab or sampling equipment (use of hexane is discouraged due to its flammability and toxicity)
Zep	General purpose cleaning
Phosphate free detergent	General purpose cleaning

Decontamination Solutions to Avoid

Some decontamination solutions should be avoided because of their toxicity, flammability, or harmful effects to the environment. Halogenated hydrocarbons, such as carbon tetrachloride, should not be used because of their toxicity, possible incompatibility, and some because of their flammability.

Organic decontamination solutions should not be used on personal protective equipment (PPE) because they may degrade the rubber or other materials comprising the PPE.

Mercurials are sometimes used for sterilization. They should be avoided because of their toxicity.

Chemical leaching, polymerization, and halogen stripping should all be avoided because of possible complications during decontamination.

Sand-blasting, a method of physical removal, should be avoided because the sand used on the contaminated object usually needs to be disposed of as hazardous waste, a very costly proposition. Also, sand-blasting exposes personnel to silica, a carcinogen.

Freon is known to be particularly effective for the cleansing of PCB's but its effect on the ozone layer is extremely harmful. Its use is discouraged.

Strong acids or bases should not be used when cleaning metals and gaskets or tools or other equipment because of the possibility of corrosion.

Disposal of Decontamination Solutions and Waste Water

All solutions and water used for decontamination must be collected. If lab analysis indicate that the water and/or solutions exceed allowable contamination levels, they must be treated as hazardous waste. Alternatively, the solutions and water may be treated on-site to lower the contamination levels and render them non hazardous.

Containers such as 55-gallon drums should be available for storage of wastes.

Spent decontamination solutions can be collected by using heavy-duty plastic sheets, visqueen sheets, kiddie pools, or if needed, a larger containment basin. The decontamination of equipment must be performed on the sheets or in the basins. They could be placed on a slight angle so that the spent decontamination solutions drain into a collection basin or drum.

Recommended Supplies for Decontamination of Personnel, Clothing and Equipment

The list below contains recommendations for supplies which would be on hand for the decontamination of personnel, clothing and equipment. Depending on the site activities, not all of these items may be needed. Alternatively, some additional items not listed here may be required.

- Drop cloths of plastic or other suitable material, such as visqueen, for heavily contaminated equipment.
- Disposal collection containers, such as drums or suitably lined trash cans for disposable clothing and heavily contaminated personal protective clothing or equipment to be discarded.
- Lined box with adsorbent for wiping or rinsing off gross contaminants and liquid contaminants.
- Wash tubs of sufficient size to enable workers to place booted foot in and wash off contaminants (without a drain or with a drain connected to a collection tank or appropriate treatment system).
- Rinse tubs of sufficient size to enable workers to place booted foot in and wash off contaminants (without a drain or with a drain connected to a collection tank or appropriate treatment system)
- Wash solutions selected to wash off and reduce the hazards associated with the contaminated wash and rinse solutions.
- Rinse solution (usually water) to remove contaminants and contaminated wash solutions
- Long-handled, soft-bristled brushes to help wash and rinse off contaminants.
- Lockers and cabinets for storage of decontaminated clothing and equipment.
- Storage containers for contaminated wash and rinse solutions.
- Plastic sheeting, sealed pads with drains, or other appropriate method for containing and collecting contaminated wash and rinse water spilled during decontamination.
- Shower facilities for full body wash or at a minimum, personal wash sinks (with drains connected to a collection tank or appropriate treatment system).
- Soap or wash solution, wash cloths and towels.
- Clean clothing and personal item storage lockers and/or closets.

Revision History		
Project #	Description	Date
1766	Formatted manual and added revision history. Identified new models VS old models and added visual aids. Updated available part numbers – StellaR	5/31/2019

NOTES

NOTES

NOTES

The Warranty

For a period of one (1) year from date of first sale, product is warranted to be free from defects in materials and workmanship. Geotech agrees to repair or replace, at Geotech's option, the portion proving defective, or at our option to refund the purchase price thereof. Geotech will have no warranty obligation if the product is subjected to abnormal operating conditions, accident, abuse, misuse, unauthorized modification, alteration, repair, or replacement of wear parts. User assumes all other risk, if any, including the risk of injury, loss, or damage, direct or consequential, arising out of the use, misuse, or inability to use this product. User agrees to use, maintain and install product in accordance with recommendations and instructions. User is responsible for transportation charges connected to the repair or replacement of product under this warranty.

Equipment Return Policy

A Return Material Authorization number (RMA #) is required prior to return of any equipment to our facilities, please call our 800 number for appropriate location. An RMA # will be issued upon receipt of your request to return equipment, which should include reasons for the return. Your return shipment to us must have this RMA # clearly marked on the outside of the package. Proof of date of purchase is required for processing of all warranty requests.

This policy applies to both equipment sales and repair orders.

FOR A RETURN MATERIAL AUTHORIZATION, PLEASE CALL OUR SERVICE DEPARTMENT AT 1-800-833-7958 OR 1-800-275-5325.

Model Number: _____

Serial Number: _____

Date: _____

Equipment Decontamination

Prior to return, all equipment must be thoroughly cleaned and decontaminated. Please make note on RMA form, the use of equipment, contaminants equipment was exposed to, and decontamination solutions/methods used.

Geotech reserves the right to refuse any equipment not properly decontaminated. Geotech may also choose to decontaminate equipment for a fee, which will be applied to the repair order invoice.

Geotech Environmental Equipment, Inc.
8035 East 40th Avenue Denver, Colorado 80207
(303) 320-4764 · (800) 833-7958 · Fax (303) 322-7242
email: geotech@ix.netcom.com website: www.geotechenv.com