

TITAN

Instrument User Manual V1.1



Register your instrument online to receive your extended warranty.

Unrivalled Detection.

www.ionscience.com

THIS PAGE IS LEFT INTENTIONALLY BLANK

Thank you for purchasing your Ion Science instrument.

Register your instrument online for extended warranty

The standard warranty of your TITAN 875 Benzene Monitor can be extended up to two years.

To receive your extended warranty, you must register your instrument online within one month of purchase (terms and conditions apply).

Visit www.ionscience.com/instrument-registration

Content

Statements	7
Validity of this Manual	7
Responsibility for Correct Use	7
Quality Assurance	7
Disposal	7
Legal Notice	7
Warranty	7
Service	8
Contact details	8
Introduction to TITAN	9
Technical specification	9
Environmental conditions	10
Un-Packing	11
Titan Benzene Monitor and Accessories Kit	11
Titan Detector Module and Accessories Kit	12
System Description	13
The Gas Detector	13
Pneumatic Connections	13
Pneumatics	13
Running Flow	14
Sampling Flow	15
Heaters	16
Outputs and Communications	17
RS485 Modbus Interface	18
Function Codes	18
Bytes and Words	18
Input Registers Address Map	18
Holding Registers Address Map	20
File Transfer	21
To read a directory	21
To read a file	22
To write a file	22
To delete a file	22
Data Files	23
System Files	23
Installation Requirements	24
Location Requirements	24
Power Requirements	24
Cable and Gland Requirements	24
RS485 Connections	24
Electromagnetic Compatibility (EMC) Requirements	25
Installation	26
Preparation for Installation	26
Dimensions for Installation	26
To Install the Housing Module	26
After-Installation Test	27
Electrical Connections	28
Removal and Installation of the Detection Module	31
To Remove the Detection Module	31
To Install the Detection Module	33
Operating the Titan	36
Switches and Display	36
Power on	36
Main screens and main menu	36
Menu Icons	37
Navigation	37
Calibration	37
Benzene Calibration	38
Flow Calibration	38
Removal of the Memory Card	39
Password Lock	39

Lock the Calibration	40
Lock the STEL and LIVE Displays	41
Alarms and Relays	41
Alarm or Relay Selection	42
Alarm Configuration	42
Relay Configuration	42
Relays and 4-20mA Test	42
Information Pages	43
Fault Indications	44
Alarm Indications	44
Service Period Reminder	45
TitanPC Software	46
Minimum requirements	46
Installation	46
Connect the Titan to the PC	46
Starting the Software	47
Data Connection	48
Settings	49
Data Download	50
Data View	51
Upgrade	53
Flow Calibration	54
Benzene Calibration	55
Recorded Faults	55
Alarm Set	57
Virtual Screen	58
Bump Test.....	59
Use of the Test.....	59
Test Procedure	59
Fault Diagnostics	60
Fault and Alarm indications.....	60
Fault Conditions	60
TitanPC Fault Groups	62
Parts List.....	63
Manual Log	65

Declaration of conformity

Manufacturer: Ion Science Ltd, The Way, Fowlmere, Cambridge, UK. SG8 7UJ

Product: 875 Benzene Monitor

Product description: A fixed monitor comprising of a GC column and photo-ionisation detector, for detecting and measuring ambient concentration of Benzene with internal data logging and 4-20mA or RS485 output

EU Directives 2014/34/EU ATEX
2014/30/EU Electrical Equipment – Electromagnetic Compatibility (EMC)

Identification  II 2 G Ex d IIB+H2 T4 Gb
Tamb. = -20°C to +55°C

Certificate Number: IECEX BAS13.0096X

Notified body: SGS Baseefa Ltd, 1180, Buxton, UK

Report number: CZ/FTZÚ/ExTR 14.0030 (IECEX) 14/0172X (ATEX)

Standards:

BS EN 60079-0: Electrical apparatus for explosive gas atmospheres. General requirements 2012

BS EN 60079-1:2007 Explosive Atmospheres - Equipment Protection by flame-proof enclosure 'd'

EN ISO 6852:2010 Flame arresters. Performance requirements, test methods and limits for use. (Replaces DIN EN 12874:2001)

EN1127-1:2007 Explosive atmospheres. Explosion prevention and protection. Basic concepts and methodology.

EN 61000-6-2:2005 Electromagnetic compatibility (EMC) generic standard for immunity for industrial environments.

BS EN 61010-1:2010 Safety requirements for electrical equipment for measurement, control and laboratory use. General requirements.

EN 61000-6-4 :2007 & A1:2011 Electromagnetic compatibility (EMC) generic standard emission standard for industrial environments.

BS EN50270:2015 Electromagnetic compatibility - Electrical apparatus for the detection and measurement of combustible gases, toxic gases or oxygen. Immunity Type 2 - industrial environments.

BS EN 61326-1:2013 Electrical equipment for measurement, control and laboratory use - EMC requirement - Part 1: General requirements. Group 1, Class A equipment - (emissions section only). Industrial Environment - (immunity section only)

DNV 2.4 : 2006 Environmental test specification for instrumentation and automation equipment. April 2006 Location Classes A and B: EMC requirements only (as verified by a technically competent test house). Conducted Low Frequency Immunity Test is pending.

Other standards

BS EN ISO 9001: 2008 Quality Management System - Requirements

BS EN 80079-34: 2011 Application of Quality Systems for equipment manufacture

Note: All measurements were performed with a configuration that assumes all screens are maintained and correctly bonded to a screened housing at each end. The only exception to this was the conducted emission tests which were performed on the inner DC cables. Performing the test directly on these lines gives a good indication that addition filtering would not be required on any AC/DC power supply in order to limit the conducted emissions contaminating the ship supply.

On behalf of Ion Science Ltd, I declare that, on the date this product accompanied by this declaration is placed on the market, the product conforms to all technical and regulatory requirements of the above listed directives.

Name: Mark Stockdale

Position: Technical Director

Date: 05/05/2016

Signature:



Statements

Validity of this Manual

This user manual gives information and procedures for the firmware and software versions shown on the front page of this manual.

If you have different versions of firmware or software, please obtain the correct user manual.

Responsibility for Correct Use

Ion Science Ltd accepts no responsibility for incorrect adjustments that cause harm or damage to persons or property. The users are responsible to respond appropriately to the readings and alarms given by Titan.

Use the equipment in accordance with this manual, and in compliance with local safety standards. Use of external circuit breakers and/or fuse protection is recommended for safe operation in the case of rare malfunction.

Reduced performance of gas detection might not be obvious, so equipment must be inspected and maintained regularly. Ion Science recommends:

- you use a schedule of regular checks to ensure it performs within calibration limits, and
- you keep a record of calibration check data.

Warnings

1. Substitution of components can result in unsafe conditions.
2. For safety, Titan must only be operated and maintained by qualified personnel.
3. Read and understand this Manual fully before you install, operate or maintain Titan.
4. ! DO NOT OPEN WHILE ENERGIZED !
5. ! DO NOT OPEN WHILE A HAZARDOUS ATMOSPHERE MAY BE PRESENT !

Quality Assurance

Titan is manufactured in compliance with ISO9001:2008. That ensures that the equipment is:

- designed and assembled reproducibly, from traceable components,
- calibrated to the stated standards before it leaves our factory.

Disposal

Dispose of Titan and its components in accordance with all local and national safety and environmental requirements. This includes the European WEEE (Waste Electrical and Electronic Equipment) directive. Ion Science Ltd offers a take-back service. Please contact us for more information.

Legal Notice

Whilst every attempt is made to ensure the accuracy of the information contained in this manual, Ion Science accepts no liability for errors or omissions, or any consequences deriving from the use of information contained herein. It is provided "as is" and without any representation, term, condition or warranty of any kind, either expressed or implied. To the extent permitted by law, Ion Science shall not be liable to any person or entity for any loss or damage which may arise from the use of this manual. We reserve the right at any time and without any notice to remove, amend or vary any of the content which appears herein.

Warranty

You can extend the Standard Warranty up to 2 years when you register your Titan instrument via our website: www.ionscience.com/instrument-registration

To receive your Extended Warranty, you must register within one month of purchase (Terms and Conditions apply). You will then receive a confirmation email that your Extended Warranty Period has been activated and processed.

Full details, along with a copy of our Warranty Statement can be found by visiting: <http://www.ionscience.com/customer-support/instrument-registration>

Service

Ion Science recommends two levels of service for the Titan.

The six-month service includes: replacement of the AirSep filter, the internal (carbon) filter, the external (hydrophobic) filter; and calibration.

The twelve-month service includes: replacement of all items listed in the six-month service, replacement of the PID lamp and electrode stack; and calibration.

Contact Ion Science or your local distributor for service options in your area.

Contact details

<p>UK Head Office Ion Science Ltd The Way Fowlmere Cambridge SG8 7UJ United Kingdom</p> <p>Tel: +44 (0)1763 207206 Fax: +44 (0) 1763 208814 Email: info@ionscience.com Web: www.ionscience.com</p>	<p>USA Office Ion Science LLC 4153 Bluebonnet Drive Stafford TX 77477 USA</p> <p>Tel: +1 (877) 864 7710 Email: info@ionscienceusa.com Web: www.ionscienceusa.com</p>	<p>German Office Ion Science Messtechnik GMBH Laubach 30 Metmann-Neandertal 40822 GERMANY</p> <p>Tel: +49 2104 14480 Fax: +49 2104 144825 Email: info@ism-d.de Web: www.ism-d.de</p>
---	---	---

Introduction to TITAN

The TITAN 875 Benzene Monitor is a fixed benzene monitor certified for Zone 1 hazardous areas. It detects 0-20ppm concentrations in ambient air, taking one sample per minute.

It monitors both the current benzene concentration and the STEL (Short-Term Exposure Limit, calculated over the previous 15 minutes).

Real-time display of the measurement is on the LCD and transmitted on a 4-20mA channel. Historic data stored in Titan can be viewed and stored externally either over the RS485 or the USB connection.

Alarms and warnings are transmitted by the 4-20mA channel and by two relays programmable to be Normally Open or Normally Closed.

It is powered by a single power supply in the range of range of 19VDC @ 4A to 32VDC @ 2.4A.

The Titan has two modules:

- The Housing Module that is installed permanently.
- The Detection Module that can be removed for servicing and calibration.

All the operational and calibration data is stored within the Detection Module. After the Detection Module has been calibrated, it will function correctly when installed in any Housing Module.

A Detection Module can be calibrated and tested off-site, then taken to the installation site and installed in place of an existing module. The removed module can then be serviced ready for installation later or in another Housing Module.

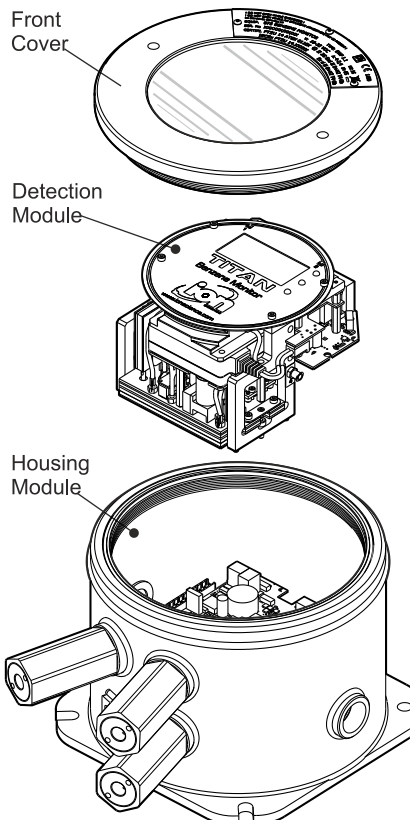

Technical specification

Measurement Frequency	Every 1 minute
Response time:	T90 < 1 minute
Detectable Range:	0-20ppm Benzene
Resolution:	+/- 0.1ppm
Accuracy:	+/- 0.05ppm or +/-10%, whichever is greater
Data log:	To internal memory (Up to 2 Years)
Outputs:	4-20mA, RS485, USB, Two programmable relays (24VDC @1.5A maximum load)
Alarms/Alerts Visual:	Red, Yellow, Green, LEDs
Flow Rate:	≥ 160 ml/min in Ambient conditions
Temperature:	Operating: -20 to 55degC (-4 to 130degF)
Power Requirement	Nominal 24VDC at 3.2A
Weight:	15kg

Environmental conditions

Location:	Outdoor use Wet conditions Pollution degree 4
Altitude:	Maximum 3000m
Relative humidity:	0 – 100RH%
Ingress protection:	IP65

Un-Packing

All equipment shipped by Ion Science Ltd is packed in containers with shock absorbing filling to protect them against physical damage.

Remove the contents carefully and check them against the packing list. Report discrepancies between the contents and the packing list to Ion Science Ltd. Ion Science will not be responsible for discrepancies not reported within ten days of your receipt of the shipment.

Every Titan (new units and those returned from a Service Centre) must have a Certificate of Calibration before you install it.

Titan Benzene Monitor and Accessories Kit

Part number	Description	Qty.
TNXSXBXX-X	Titan 875 Benzene Monitor and Accessories Kit Comprising:	Kit
A-875281	Housing Module	1
A-875245	Detector Module	1
875413	Front Cover Removal Tool	2
875400	Transit Strap	1
2/SH10-16	Transit Strap Screws (M10x16)	2
A-875265	Switch Actuation Magnet	1
A-875417	External (Hydrophobic) Filter	1
4/PB-05	Gland Port Plug (for transportation)	2
4/TA-06	Allen Key 2mm	1
4/TA-08	Allen Key 3mm	1
875431	Mounting Template	1
875263	Titan User Manual	1
–	Certificate of Calibration	1

Titan Detector Module and Accessories Kit

Part number	Description	Qty.
TSMXSXXXX-X	Titan Detector Module and Accessories Kit Comprising:	Kit
A-875245	Titan Detector Module	1
875405	Transit and Storage Case	1
875413	Front Cover Removal Tool	2
4/TA-06	Allen Key 2mm	1
4/TA-08	Allen Key 3mm	1
–	Certificate of Calibration	1

Titan Label Information: Ensure Warning Label is attached to Titan

! DO NOT OPEN WHILE ENERGIZED !

! DO NOT OPEN WHILE A HAZARDOUS ATMOSPHERE MAY BE PRESENT !



Refer to instruction manual/booklet



Separate collection for WEEE-Waste of electrical and electronic equipment



IP65

Dust-tight and protected against water jets

System Description

The Gas Detector

The Titan samples the ambient air once every 60 seconds and passes the sample through a Photo-Ionisation Detector (PID).

The PID works by illuminating sample gases with high energy ultra-violet (UV) light. Benzene is one of the volatile organic compounds (VOCs) ionised by the UV photons. In a high voltage electric field, these ions create a current that can be amplified and measured to quantify the concentration of gases present. To make the measurements specific to benzene, it must be separated out from the other gasses before the PID measurement.

The sample passes through the AirSep filter which retards some gas components more than others. Under controlled conditions the filtration ensures the benzene will pass through the filter at a known and well defined time as a separated component. The benzene level is measured by analysis of the signal profile of the PID as the gasses from the AirSep filter pass through it.

For optimum performance it is important that the filter temperature and sample flow are tightly controlled. To achieve temperature stability, the AirSep filter is controlled to 50degC and the internal air temperature of the Titan is controlled to a maximum of 50degC by separate heating systems

There is no forced cooling mechanism so if the ambient temperature exceeds 50degC the measurement of benzene will be lower than the actual concentration.

Make sure to install the Titan where the ambient temperature does not rise above 50degC.

Pneumatic Connections

The Titan has three flame-arrestor connectors: one inlet and one outlet for the sampled air, and one breather. The breather keeps pressure equilibrium between inside and outside of the housing.

The inlet flame-arrestor can have a probe tube, up to 10m long, with hygroscopic filter, to detect benzene in areas remote from the Titan.

The outlet flame-arrestor can have an exhaust tube attached, to remove the processed air away from the inlet. Internally, there is also an inlet through the carbon filter and an outlet into the interior space.

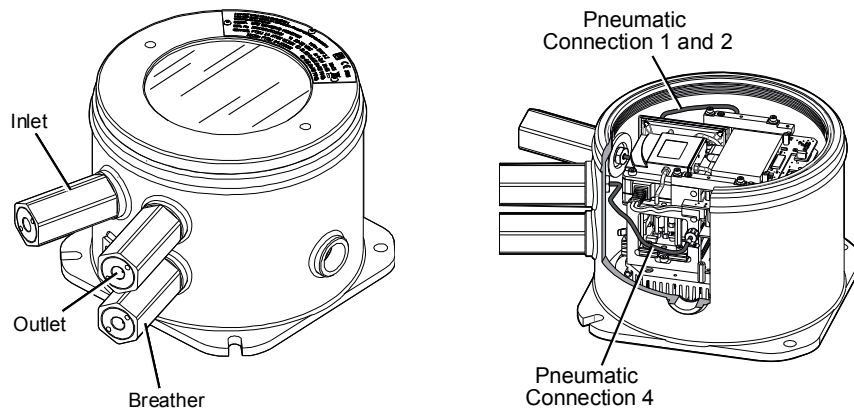

Pneumatics

In running flow:

- Pump P2 runs for 40 seconds out of every one minute cycle. The pump is stopped for twenty seconds to allow accurate sampling by Valve V1. When the Valve V1 is in its normal "running" position, the air bypasses the Photo-Ionization Detector (PID).
- Pump P1 keeps a constant flow of clean air from the internal (carbon) filter through the PID. Pump P1 outlet is inside the housing. Thus the clean air recycles through the internal (carbon) filter.

In sampling flow:

- At 60 second intervals, Valve V1 moves to its "sampling" position for 0.5 seconds.
- Pump P1 then draws a sample of air from the Pump P2 flow. Through the AirSep filter and the PID.
- Analysis of the PID signal profile gives the benzene concentration.

Pump P1 flow is approximately 8mL per min.

Pump P2 flow is approximately 200mL per min.

The pressure sensors monitor the correct functioning of the pneumatic systems.

The external (hydrophobic) filter removes particles and moisture from the inlet Flow. Every three hours by the clock (00:00, 03:00, 06:00...) the Titan will stop to measure the ambient pressure conditions to correctly adjust for flow control. Important note: bump testing is inadvisable at these times as external pressure sources will affect the pressure calibration process

Running Flow

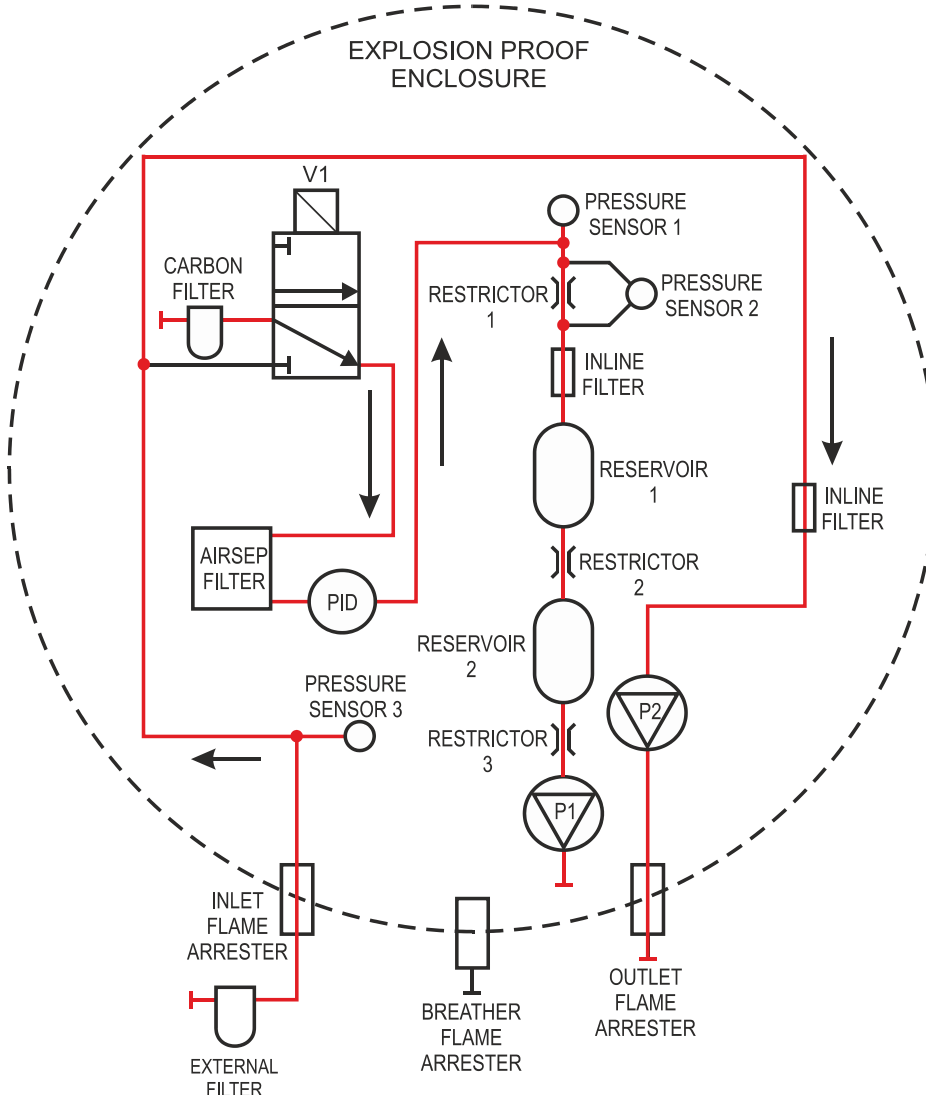

Sampling Flow

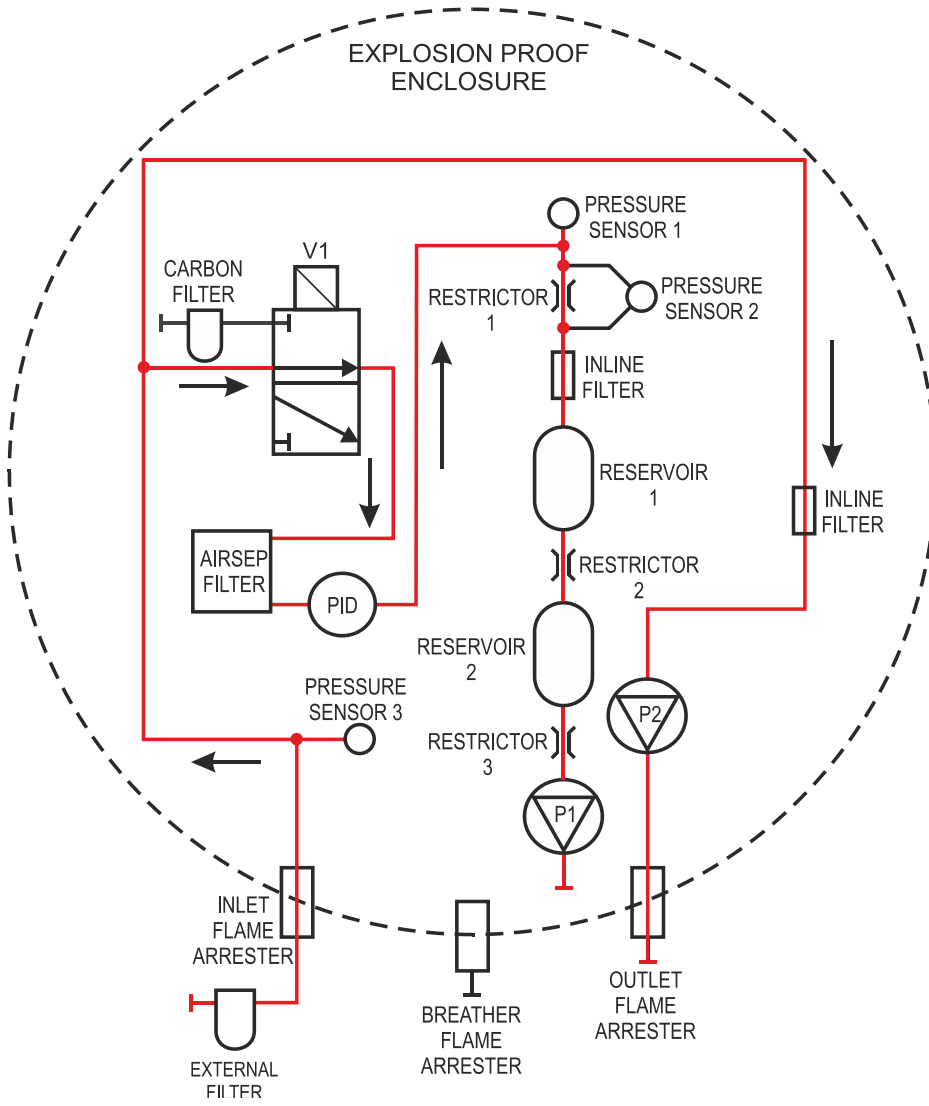

Heaters

The Titan has two heating systems, one regulates the internal temperature, the other regulates the temperature of the AirSep filter.

Internal temperature regulation is maintained by a set of four resistors in the base of the Housing Module.

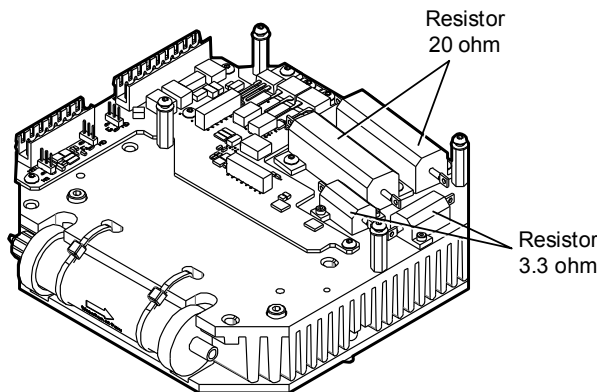

AirSep filter temperature regulation is by two, 12V 2.5W, heater-mats within an insulated jacket in the Detection Module.

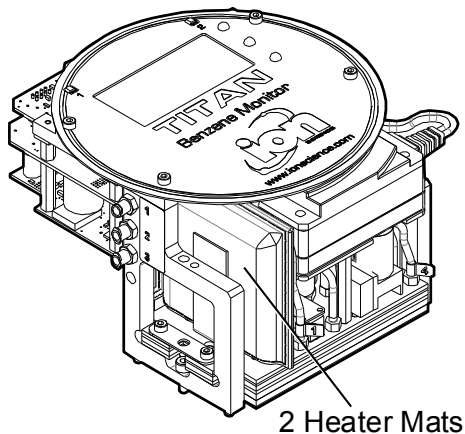

Outputs and Communications

Titan has five communication outputs:

- The on-board LCD and LEDs on the faceplate.
- 4-20mA Current Loop.
- RS485 Modbus (simplex/half-duplex or fully-duplex),
- USB (Accessible on the Detector Module).
- Two programmable relays.

Titan monitors, in real-time, the current (Live) and the Short-Term Exposure Limit (STEL) benzene concentration. The STEL is calculated over the previous 15 minutes.

This real-time information is displayed on the LCD and transmitted on the 4-20mA and RS485 channels.

You can program two alarms to operate at a chosen concentration of benzene and/or a chosen STEL limit. The alarms will display a message on the LCD and LEDs; energize the relays; and transmit a signal on the 4-20mA channel.

The alarms and relays are individually programmable to the settings required by the site policy. You can choose either alarm to energize either relay. The default settings would be:

- Alarm 1: 5.0ppm live
- Alarm 2: 0.5ppm STEL
- Relay 1: Alarm 1, N/O
- Relay 2: Alarm 2, N/O

Both relays can be programmed to be Normally Open or Normally Closed. They can switch 24VDC at 1.5A maximum load. When the Titan is not powered the default state of relay 1 is N/C, the default state of relay 2 is N/O

Data is stored internally for a minimum of two years and can be downloaded with TitanPC software via USB or RS485 for analysis and archive storage.

You can configure the RS485 connection for half-duplex, 2-wire, or full-duplex, 4-wire, communication. Refer to Installation, [Terminal Block-2](#).

The 4-20mA output fault indications are given by discrete current signals between 2.0 and 3.5mA. Refer to the table in Fault Diagnostics, [Fault Conditions](#).

RS485 Modbus Interface

The Titan Modbus interface uses Serial ASCII format Modbus, at:

- 38400 baud 8 data bits, no parity, 2 stop bits.

Function Codes

Titan supports these function codes:

- 0x03 – Read Holding Registers
- 0x04 – Read Input Registers
- 0x10 – Write Multiple Registers

The address map for Read Holding Registers and Write Multiple Registers is the same – but not all addresses are writeable.

Bytes and Words

Modbus registers are generally 16 bits in length. For example if you send the command to Read Input Registers with a register quantity of 1 you will receive 2 bytes (1 word) of data. In the tables of addresses, we specify the length in bytes. This is the number of bytes of data associated with the read/write at that address.

Thus your Modbus request will be for half that number of registers.

Input Registers Address Map

Use the function code 0x04 to Read Input Registers in the address range given in the table. If you read more than the number of bytes indicated for the length at each address, any bytes beyond the length are undefined.

For example, if you read 32 bytes at address 1000, only the first 16 bytes returned are valid.

Address (hex)	Data Length (bytes)	Content
0	60	Returns block of 15 integers for latest result Integer Meaning 1 Benzene value in ppm x 10 2 Sensor temperature in degC x 100 3 Ambient temperature in degC x 10 4 Flow in ml/min x 100 5 PS1 diagnostic 6 PS2 diagnostic 7 PS3 diagnostic 8 Slope diagnostic 9 Flags 10 Sensor fence signal 11 Raw signal 12 STEL value 13 Pump drive signal 14 Pump drive volts 15 Fault record
80	24	Returns block of data indicating the state of the sensor temperature controller. Six 32-bit integers are returned. e.g. 00000000 84 13 00 00 22 02 00 00 AD 08 00 00 A0 0F 00 00 00000010 01 00 00 00 01 00 00 00 These can be decoded as follows: 84 12 00 00 = 0x00001284 = 4740 The values have the following meaning Integer Meaning 1 Temperature in degrees Celsius x 100 2 Ambient temperature in degC x 16 3 Heater drive power in % x 100

		<p>4 Heater driver voltage</p> <p>5 1 if required temperature has been reached</p> <p>6 Time in seconds taken to reach target from switch on</p>
100	24	<p>Returns block of data indicating state of background temperature controller. Six 32-bit integers are returned. e.g.</p> <pre>00000000 FC 44 00 00 21 02 00 00 00 00 00 01 00 00 00 üD··!·········· 00000010 EF 00 00 00 02 00 00 00 00 00 00 00 00 00 ······</pre> <p>Integer Meaning</p> <ul style="list-style-type: none"> 1 Heater Temperature in degC x 100 2 Ambient temperature in degC x 16 3 Heater drive power in % x 100 4 Heater driver voltage 5 Power supply level x 10 6 Heater level
1000	16	<p>Unique ID of Titan – a string of 16 ASCII characters unique to each Titan</p>
1100	32	<p>Firmware versions of Titan and Flow Controller. Two null terminated strings are returned. e.g.</p> <pre>00000000 56 30 2E 31 2E 33 33 00 56 30 2E 31 2E 31 31 00 V0.1.33-V0.1.11· 00000010 00 00 00 00 00 00 00 00 00 00 00 00 00 00 00 ··········</pre>
1200	36	<p>Returns a block of data indicating the state of the flow.</p> <p>This block contains 9 32-bit integers. e.g.</p> <pre>00000000 21 03 00 00 DA 0D 00 00 20 2F 00 00 88 00 00 00 !···Ü··· /·^··· 00000010 01 00 00 00 00 00 00 00 00 00 00 00 00 00 00 ······</pre> <p>These can be decoded as follows: 21 03 00 00 = 0x00000321 = 801</p> <p>The values have the following meaning:</p> <p>Integer Meaning</p> <ul style="list-style-type: none"> 1 Current flow x 100 2 Flow Differential pressure sensor reading 3 Absolute pressure sensor reading 4 Pump power output 5 1 if pump power OK, 0 if pump power problem 6 1 if outer loop pump running, 0 if outer loop pump not running 7 Pump drive output voltage 8 Absolute pressure when pump not running 9 Valve state
1300	12	<p>Returns information on the internal memory storage. Three 32-bit integers are returned.</p> <p>Integer Meaning</p> <ul style="list-style-type: none"> 1 Number of free clusters. 2 Total available clusters 3 Reserved clusters.
1400	96	<p>Returns an array of 27 32-bit integers indicating internal fault state of Titan. If there are no faults all values are zero.</p>

1500	20	Returns five 32-bit integers indicating state of the lamp sensor. <table border="0"> <tr> <td>Integer</td> <td>Meaning</td> </tr> <tr> <td>1</td> <td>Last signal reading in μV</td> </tr> <tr> <td>2</td> <td>1 is lamp is on, 0 if not</td> </tr> <tr> <td>3</td> <td>0 if lamp drive is off, non-zero if lamp drive is on</td> </tr> <tr> <td>4</td> <td>Lamp sensor signal when lamp off, in μV</td> </tr> <tr> <td>5</td> <td>Last Lamp sensor signal reading in μV</td> </tr> </table>	Integer	Meaning	1	Last signal reading in μV	2	1 is lamp is on, 0 if not	3	0 if lamp drive is off, non-zero if lamp drive is on	4	Lamp sensor signal when lamp off, in μV	5	Last Lamp sensor signal reading in μV
Integer	Meaning													
1	Last signal reading in μV													
2	1 is lamp is on, 0 if not													
3	0 if lamp drive is off, non-zero if lamp drive is on													
4	Lamp sensor signal when lamp off, in μV													
5	Last Lamp sensor signal reading in μV													
1600	6	Returns three 16-bit values containing diagnostic data for pressure sensor												

Holding Registers Address Map

Read Holding Registers – use function code 0x03.

Write Holding Registers – use function code 0x01 (Write Multiple Registers).

If you read or write more than the number of bytes specified for the length at each address, any bytes beyond the length are undefined.

Titan can malfunction if you write more data than the specified length.

For example if you read 32 bytes at address 1000, only the first 16 bytes returned are valid.

Address (hex)	Data Length (bytes)	Content																		
1100	32	ASCII name allocated to the Titan. This may be written or read. e.g. <pre>00000000 53 65 72 76 69 63 65 20 54 69 74 61 6E 00 00 00 Service Titan... 00000010 00 00 00 00 00 00 00 00 00 00 00 00 00 00 00 00</pre>																		
1200	32	Internal real time clock. This may be written or read. e.g. <pre>00000000 DF 07 00 00 02 00 00 00 0A 00 00 00 10 00 00 00 β..... 00000010 11 00 00 00 29 00 00 00 02 00 00 00 00 00 00 00).....</pre> <p>This is decoded as 8 32-bit numbers. The last two integers are not used when writing.</p> <table border="0"> <tr> <td>Integer</td> <td>Meaning</td> </tr> <tr> <td>1</td> <td>Year</td> </tr> <tr> <td>2</td> <td>Month</td> </tr> <tr> <td>3</td> <td>Day</td> </tr> <tr> <td>4</td> <td>Hour</td> </tr> <tr> <td>5</td> <td>Minute</td> </tr> <tr> <td>6</td> <td>Second</td> </tr> <tr> <td>7</td> <td>Day of week</td> </tr> <tr> <td>8</td> <td>Day of year</td> </tr> </table>	Integer	Meaning	1	Year	2	Month	3	Day	4	Hour	5	Minute	6	Second	7	Day of week	8	Day of year
Integer	Meaning																			
1	Year																			
2	Month																			
3	Day																			
4	Hour																			
5	Minute																			
6	Second																			
7	Day of week																			
8	Day of year																			
1300		Used during code upgrade. For ISL use only. Reading or Writing to this address may require you to send the Titan to a Service Center.																		
1400		Used during upgrade of flow controller. For ISL use only. Reading or Writing to this address may require you to send the Titan to a Service Center.																		
1500	4	Override control of measuring sequence. For ISL use only.																		
1600	4	Override control of pump. For ISL use only.																		
1604	4	Override control of by-pass pump. For ISL use only.																		
1608	4	Override control of sample valve. For ISL use only.																		

1700	28	<p>Read latest result data.</p> <p>A block of 7 32-bit integers is returned</p> <table> <thead> <tr> <th>Integer</th> <th>Meaning</th> </tr> </thead> <tbody> <tr> <td>1</td> <td>Benzene value in ppm x 10</td> </tr> <tr> <td>2</td> <td>Results Flags</td> </tr> <tr> <td>3</td> <td>Flag indicating start of measurement cycle</td> </tr> <tr> <td>4</td> <td>Diagnostic Step in measurement cycle</td> </tr> <tr> <td>5</td> <td>Last sensor reading</td> </tr> <tr> <td>6</td> <td>Stel result in ppm x 10</td> </tr> <tr> <td>7</td> <td>Last fault</td> </tr> </tbody> </table> <p>Writing to any space in this address range will clear flag indicating start of measurement cycle (integer 3).</p>	Integer	Meaning	1	Benzene value in ppm x 10	2	Results Flags	3	Flag indicating start of measurement cycle	4	Diagnostic Step in measurement cycle	5	Last sensor reading	6	Stel result in ppm x 10	7	Last fault
Integer	Meaning																	
1	Benzene value in ppm x 10																	
2	Results Flags																	
3	Flag indicating start of measurement cycle																	
4	Diagnostic Step in measurement cycle																	
5	Last sensor reading																	
6	Stel result in ppm x 10																	
7	Last fault																	
1800		Diagnostic, test control of 4-20mA output. For Ion Science use only.																
F000	44	Block of data controlling file transfer to/from internal store. Write only.																
F080	16	Block of data giving information on file transfer to/from internal store. Read only.																
F100	128	Used to read/write data from/to files on internal store.																

File Transfer

Titan has an internal file store to hold files containing configuration/setup data and data logs of results. You can read or write to these using read and write to holding registers at addresses F000, F080, F100.

File transfer is by three structures defined as follows (in C):

```
COMPILER_ALIGNED(4)
static struct {
    unsigned short direction;
    unsigned short pack;
    union
    {
        unsigned int offset;
        char filename[40];
    } d;
} filename_data;
```

```
COMPILER_ALIGNED(4)
static struct {
    int res;
    int state;
    int offset;
    int length;
    union
    {
        FIL hFile;
        DIR hDir;
    };
} fileinfo;
```

```
static struct {
    int attribute;
    int length;
    char name[40];
} directory_entry;
```

To read a directory

- Write to F000 a filename_data block with values:
direction = 5
filename = ASCII zero terminated path to read, '/' indicates root folder.
- Read from F080 a fileinfo block. Check that res = 0, State = 2 to indicate directory read open OK.

3. Read from F100 a 128 byte block. This will contain a directory_entry. The length field is the length of the file name in 'name'. The attribute is a bitmap combination of:

```
#define    AM_RDO    0x01    /* Read only */
#define    AM_HID    0x02    /* Hidden */
#define    AM_SYS    0x04    /* System */
#define    AM_VOL    0x08    /* Volume label */
#define    AM_LFN    0x0F    /* LFN entry */
#define    AM_DIR    0x10    /* Directory */
#define    AM_ARC    0x20    /* Archive */
#define    AM_MASK    0x3F    /* Mask of defined bits */
```

4. Read from F080 a fileinfo block. This contains status information about the last directory entry read. Check res=0 to indicate success.
5. Repeat steps 3 and 4 until whole directory is read. A return in the fileinfo block with res <> 0 indicates end of directory.
6. Write to F000 a filename_data block with values:
direction = 6
to close the directory read.

To read a file

1. Write to F000 a filename_data block with values:
direction = 0
filename = ASCII zero terminated path to read, '/' indicates root folder.
2. Read from F080 a fileinfo block. Check that res = 0, State = 1 to indicate file read open OK. File length will be in the length parameter.
3. Read 128 bytes of data from F100.
4. Read a fileinfo block from F080. Check res=0 and the offset has incremented by 128.
5. Repeat steps 3 and 4 to read whole file.
6. Write to F000 a filename_data block with values:
direction = 2
to close the file

While reading a file you can rewind by:

1. Write to F000 a filename_data block with values:
direction = 3;
offset = offset required
2. Read a fileinfo block from F080. Check res = 0 and offset is as required.

To write a file

1. Write to F000 a filename_data block with values:
direction = 1
filename = ASCII zero terminated path to read, '/' indicates root folder.
2. Read from F080 a fileinfo block. Check that res = 0, State = 1 to indicate file write open OK.
3. Write up to 128 bytes of data to F100.
4. Read a fileinfo block from F080. Check res=0 and the offset has incremented by 128.
5. Repeat steps 3 and 4 to write whole file.
6. Write to F000 a filename_data block with values:
direction = 2
to close the file.

To delete a file

1. Write to F000 a filename_data block with values:
direction = 4
filename = ASCII zero terminated path to delete.
2. Read from F080 a fileinfo block. Check that res = 0, to indicate file deleted OK.

Only single files may be deleted, the filename should be the full path to the file, e.g. /20150510/123456.txt

Data Files

Data files are written by Titan every minute.

Data files are appended to a folder whose name is made from the current date, e.g. 20150301 will be the folder for 1st March 2015.

Within the Date folder there is a folder named RESULTS containing a series of TXT files. The filename is made up of 8 hex characters which is the time of the file in seconds since 1/1/2010.

The files in the RESULTS folder contain ASCII information of the result, e.g.

```
Date,17/02/2015
Time,15:54
Benzene,0.0
STEL,2.1
Col Temp, 50.01
Amb Temp, 31.3
Flow,7.47
PS1,988
PS2,3828
PS3,6865
Slope,4000
Flags,1
Fence,22217
DriveDac,105
DriveVolt,63.0
Faults,0
```

To read logged data from the Titan use the Directory read commands to see what directories of type yyyymmdd exist. Then read the RESULTS sub-folder to see the data files available.

System Files

Titan stores configuration parameters in *.CFG files in the file store.

Titan can malfunction if you delete or modify these files.

Installation Requirements

Please make sure you understand all the installation requirements before you install Titan.

Location Requirements

There are many variables involved in defining the optimum location for a gas detector. Mount the Titan:

- in a location where it (or its inlet probe) is most likely to detect the gas
- in an area that has good air circulation. Restricting natural air current can result in delayed detection
- on a solid, stable support, where it is accessible for servicing
- vertically, with the flame arresters underneath the housing
- not in direct sunlight or over a heat source (This can cause the Titan to exceed its certified internal working temperature of 50degC)
- not in areas likely to flood.

An exhaust line can be attached to the outlet flame-arrestor to remove the processed air away from the Titan.

An inlet line (inlet probe), with hydrophobic filter can be attached to the inlet flame-arrestor to detect benzene in areas remote from the Titan.

These lines can be

- Maximum of 10 meters long.
- Recommended cross-section: 6mm OD x 4mm ID PTFE tube.

Power Requirements

Nominal Voltage 24VDC @ 3.2A

Minimum Voltage 19VDC @ 4A

Maximum Voltage 32VDC @ 2.4A

We recommend a power supply unit of 24VDC at 4.5A.

Power consumption depends on the heaters in the temperature control systems. Running in ambient temperatures below 5degC will use maximum power. Higher temperatures will reduce power consumption.

The 4-20mA output requires its own power supply at 24 (minimum) to 32VDC (maximum). It can share the instrument's 24 to 32VDC, 4.5A, power supply if:

- the 4-20mA output goes to the same location as the instrument power supply and
- their Grounds will be connected together.

Refer to Electrical Connections, [Terminal Block-1](#).

Cable and Gland Requirements

We recommend you use screened cables e.g., multicore cable with SWA armour, or Braid Armour to protect against EMI.

The manufacture and build of the cable glands is the responsibility of the installer. The cable glands must conform to the certification standards required for the installation site. Install blanking plugs with the appropriate certification standards to unused cable gland ports.

For general advice on selection of cable glands please visit <http://www.cmp-products.com/cable-gland-selection-guidelines>.

DC power	2 core (positive and negative) 1.5mm ²
4-20mA Comms	2 core 1.5mm ² max
RS485 half-duplex	3 cores (including ground) 1.5mm ² max
RS485 full-duplex	5 cores (including ground) 1.5mm ² max
Relays (2 Outputs)	4 cores 1.5mm ² max
Cable Gland	¾" NPT - Intrinsically Safe Certified
Blanking Plug	¾" NPT - Intrinsically Safe Certified

RS485 Connections

You can configure Titan for half-duplex, 2-wire, or full-duplex, 4-wire, communication. You can also configure it to use a built-in 120R termination resistor.

Pin references are to Terminal Block-2 (Refer to Installation, [Terminal Block-2](#))

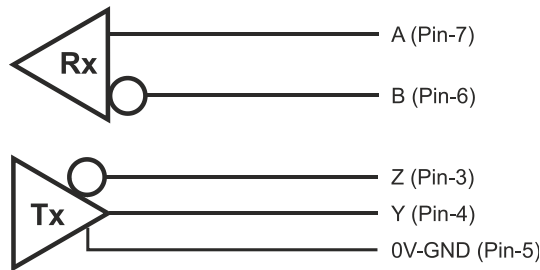

To connect a 120R termination resistor across 'A' and 'B': connect a jumper on L1 between the middle pin and 120R pin. (Refer to Note 1 of [Terminal Block-2](#), Installation).

For Half-Duplex communication, connect jumpers on L2 and L3 between the middle pin and HD pin (Refer to Note 2 of [Terminal Block-2](#), Installation).

This enables 2-wire communications and a 3rd wire ('0') as a Ground.

- 'A' is connected to 'Y'
- 'B' is connected to 'Z'
- '0' is Ground

For Full-Duplex communication, connect jumpers on L2 and L3 between the middle pin and D pin (Refer to Note 3 of [Terminal Block-2](#), Installation).

This enables 4-wire communications and a 5th wire ('0') as a Ground.

Electromagnetic Compatibility (EMC) Requirements

Titan can be sensitive to electromagnetic interference in the 1.8 to 2.0GHz range. If it will be exposed to strong signals in that range please contact Ion Science for a faceplate with increased protection against electromagnetic interference (EMI).

Installation

Preparation for Installation

Before you install the Titan, refer to the:

- Location Requirements ([Location Requirements](#))
- Power Requirements ([Power Requirements](#))
- Cable and Gland Requirements ([Cable and Gland Requirements](#))
- Dimensions for Installation (See below)
- RS485 Interface Requirements ([RS485 Connections](#), [RS485 Modbus Interface](#))

Dimensions for Installation

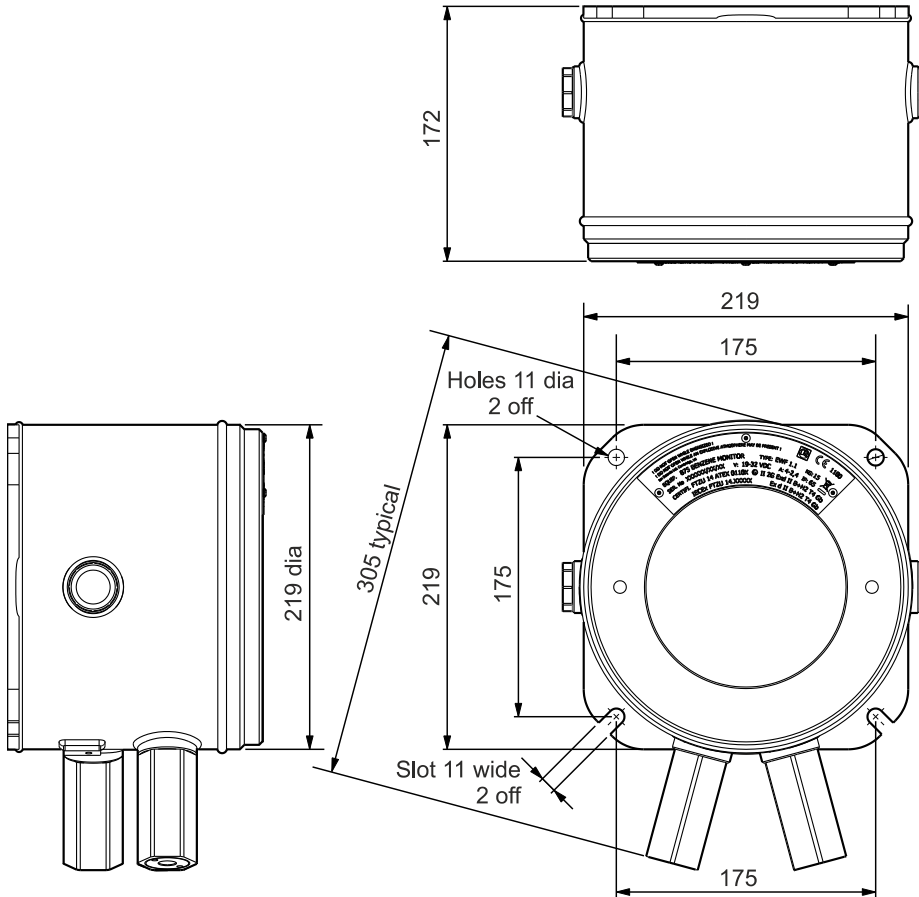

All Dimensions in mm

To Install the Housing Module

1. Use M10 screws to install the Titan as a complete unit (Housing and Detection Modules together) on a solid, stable support.
2. After you install the Titan, remove the Detection Module to get access to the terminal blocks. Refer to [Removal and Installation of the Detection Module](#)
3. Install the cable glands. Feed the cables through the glands and make the connections to the terminal blocks as you require. Refer to [Electrical Connections](#).
4. Seal the cables in the cable glands.
5. Install the Detection Module.
6. Connect, or switch on, the power supply.
7. Connect a PC/Laptop to the USB port and use TitanPC to set the date and time. Alternatively, use the RS485 connection and TitanPC to set the date and time. Without external power, Titan can only store the current date and time for a maximum of 12 hours.
8. Install the front cover.

After-Installation Test

Do a test of the relay and the 4-20mA systems to check for correct installation and function. Refer to [Relays and 4-20mA Test](#).

Do a "Bump Test" to verify that the sensors respond correctly to the Benzene gas. Refer to Bump test. for an accurate bump test the Titan needs to heat up and thermally stabilise. This can take up to 90 minutes. Before this an inaccuracy of up to 15% could be seen.

A bump test does not calibrate the sensors. If Titan does not display the gas concentration given by the bottle, do a calibration to give the correct readings. Refer to Benzene Calibration (on-board) or [Benzene Calibration](#) (using TitanPC).

Electrical Connections

Terminal Block-1 (Power)

Pin	Label	Function
1	0V	DC Power input (Negative)
2	0V	DC Power additional input (Negative) (Connected to above Pin1 on-board) (See Note 1)
3	24	DC Power Input (Positive) +24VDC
4	24	DC Power additional input (Positive) (Connected to above Pin3 on-board) (See Note 1)
5	R1	Relay 1 output (Terminal-1)
6	R1	Relay 1 output (Terminal-2)
7	R2	Relay 2 output (Terminal-1)
8	R2	Relay 2 output (Terminal-2)
9	Is	DC Power Output (Positive) (Connected to Pin3 & 4 on-board) (See Note 2)

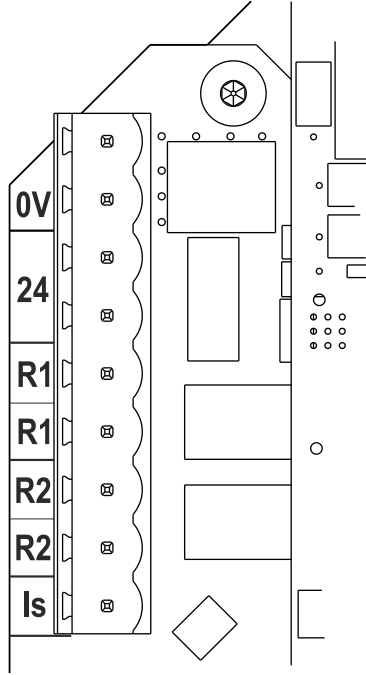

Notes

- Pin 2 '0V' and pin 4 '24V' on Terminal Block-1 allow two wires to share the current of the Power Supply Input.
Pin 1 and Pin 2 are connected together on-board.
Pin 3 and Pin 4 are connected together on-board.
- The 4-20mA output is NOT powered on-board. It is an isolated output that requires its own Power Supply at 24VDC (nominal) and 32VDC (maximum).
The 4-20mA output can share the instrument Power Supply if:
 - the 4-20mA output goes to the same location as the instrument power supply and
 - their Grounds will be connected together.

If that is so, connect a jumper from Pin 9 of Terminal Block-1 to Pin-1 of Terminal Block-2

Terminal Block-2 (Communications)

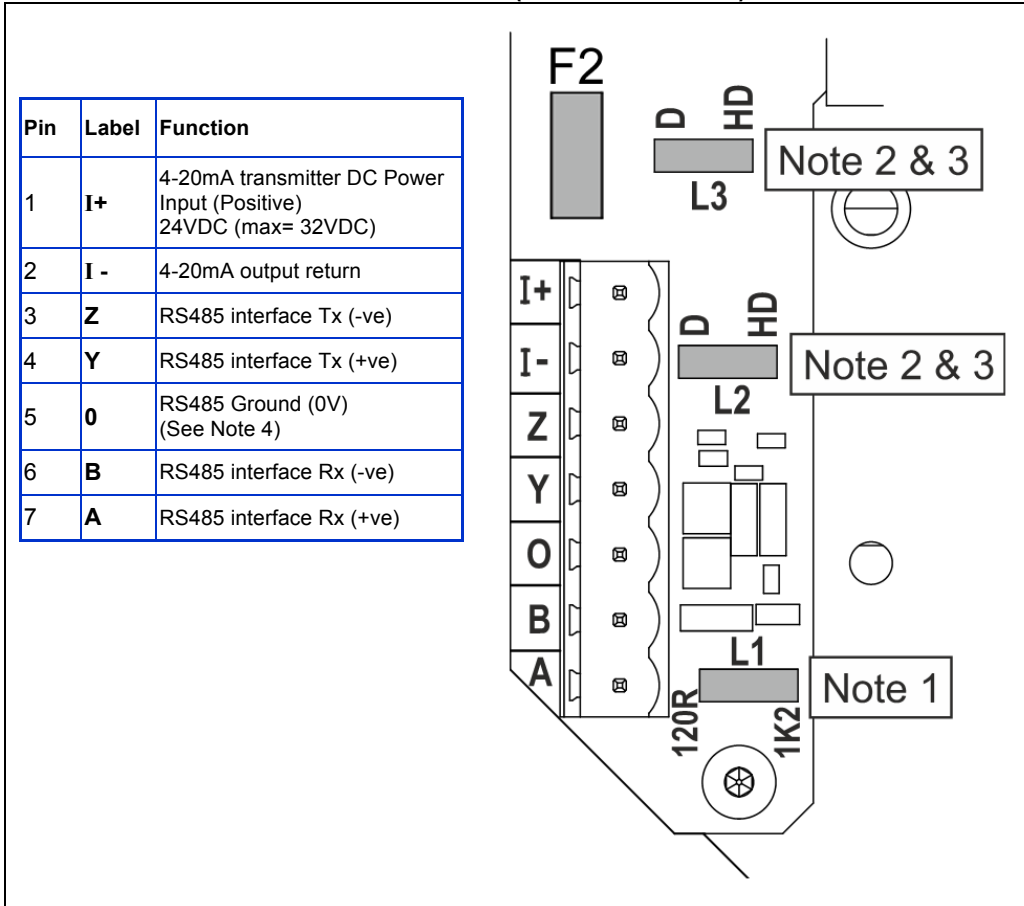

Notes

1. For RS485 termination resistor, put a jumper link on the L1 header between the middle pin and the pin labelled 120R. This puts a 120R termination resistor across 'A' and 'B' of Terminal Block-2 (See RS485 Connections diagram for more details). To disconnect the resistor remove the jumper completely.
2. For RS485 Half Duplex communication put jumpers on headers L2 & L3 between the middle pin and the pin labelled 'HD'.
3. For RS485 Full Duplex communication put jumpers on headers L2 & L3 between the middle pin and the pin labelled 'D'.
4. The RS485 interface is an isolated interface. The Pin 5 Ground connection '0' on Terminal Block 2 is electrically isolated from the instrument's Ground.
5. The 4-20mA output has an inline fuse, see F2 on the above diagram.

Circuit diagrams for 4-20 mA monitoring

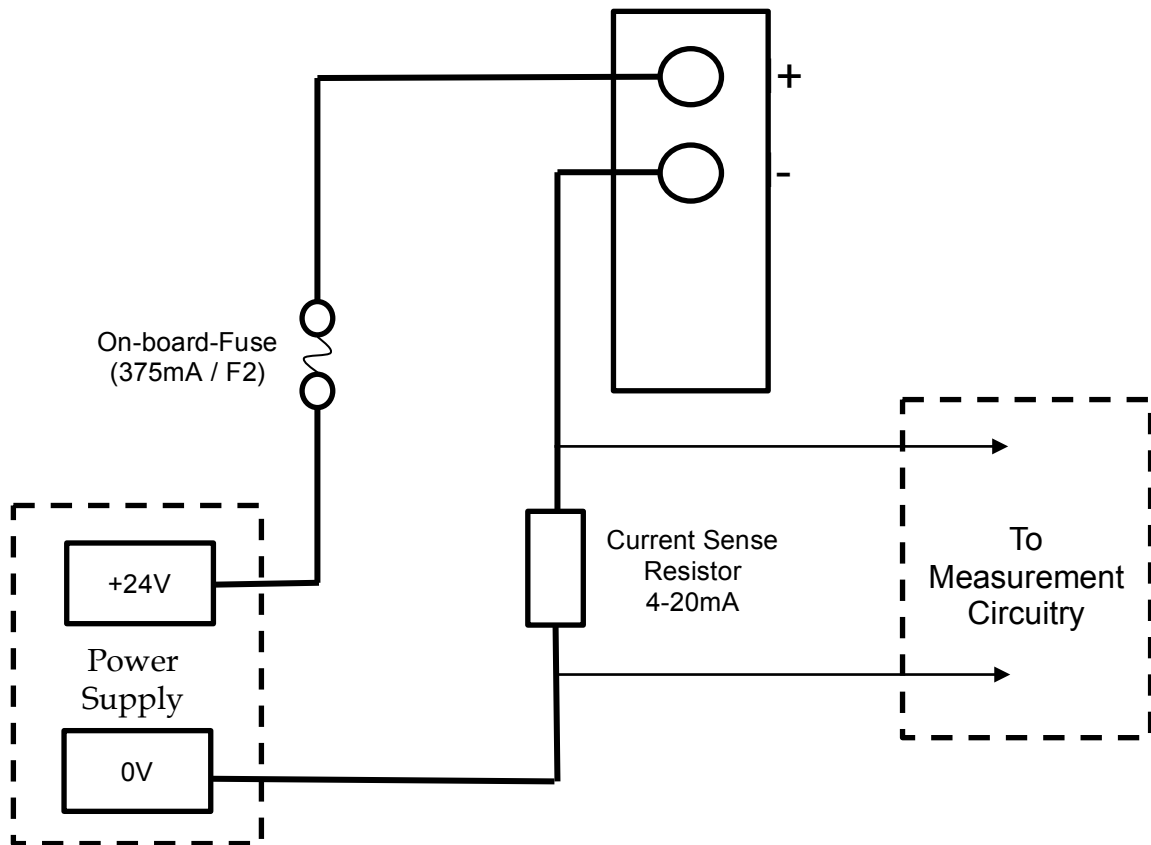
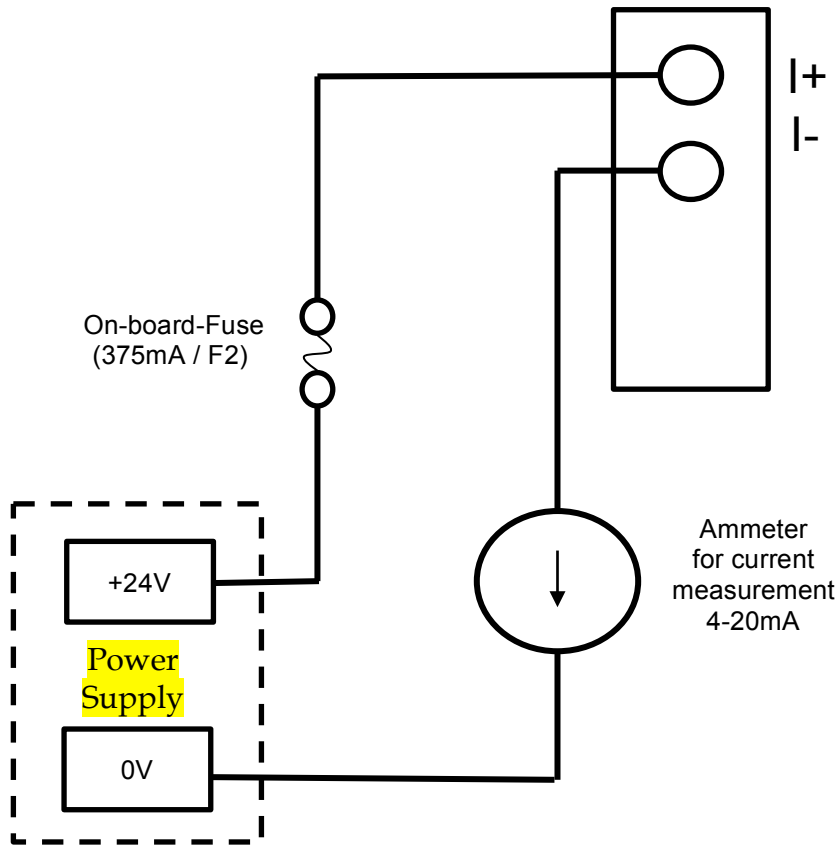

Removal and Installation of the Detection Module

To Remove the Detection Module

Switch off or remove the power to the Titan.

Warning

1. Ensure the electrical power is switched off or disconnected.
2. Do not open when an explosive atmosphere might be present.

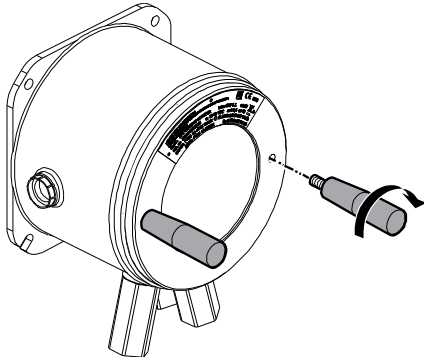

Insert the threaded Cover Removal Tools into the holes in the Titan front cover.

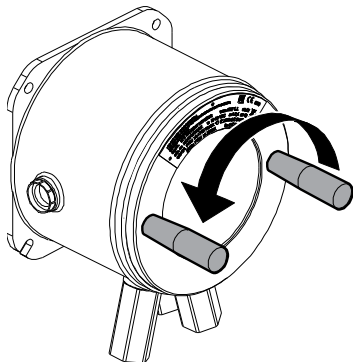

Turn counter-clockwise to unscrew the front cover.

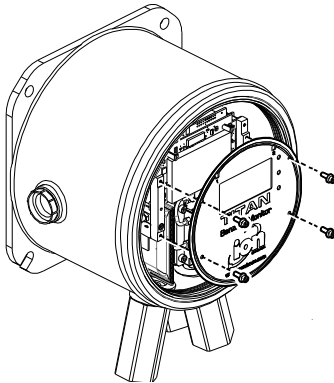

Use a 2mm allen-key to remove the four faceplate screws.

Remove the faceplate.

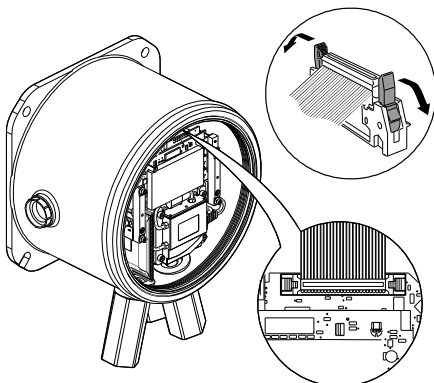

Press the 'wings' down to release the ribbon cable at the top of the Detection Module.

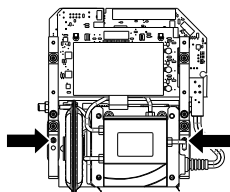

Two captive, hex-socket screws hold the Detection Module in the Housing Module, as shown.

Two holes in the front of the

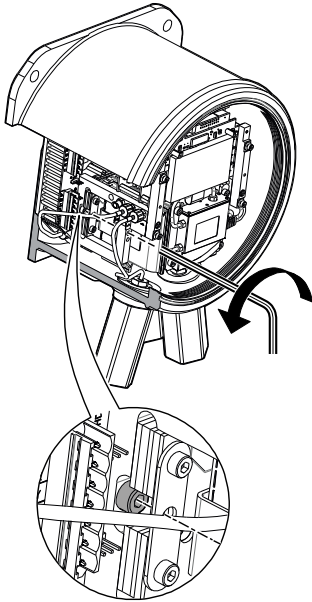

Detection Module give access to the screws.

Use a 3mm allen-key to reach the screws directly behind the holes.

Turn each screw counter-clockwise until it is completely loose.

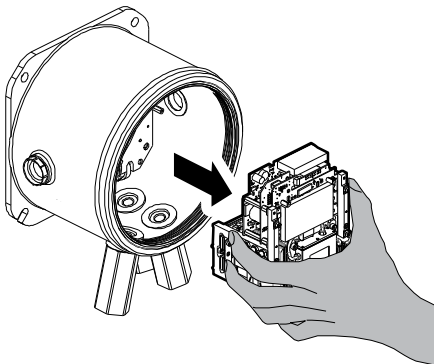

When the captive screws are completely loose, grip the sides of the frame of the Detection Module, as shown, to remove it from the Housing Module.

Be careful not to cause damage the PCBs.

Be careful to remove it only far enough to disconnect the Luer connectors of the 3 pneumatic tubes.

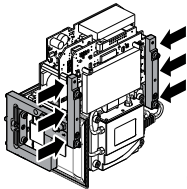

Grips

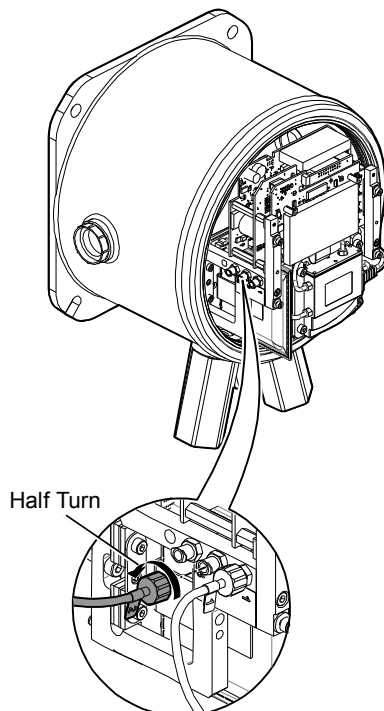

Ensure the pneumatic tubes are properly identified for later connection to the correct connectors.

Disconnect the tubes only from the Detection Module, not from the Housing Module. The tubes must remain connected at all times to the barbs on the interior face of the flame-arrestors.

For complete removal of the Detection Module: a half-turn, counter-clockwise, of the Luer connectors will remove the pneumatic tubes:

- two on the left
- one on the right.

You can now remove the Detection Module completely.

To Install the Detection Module

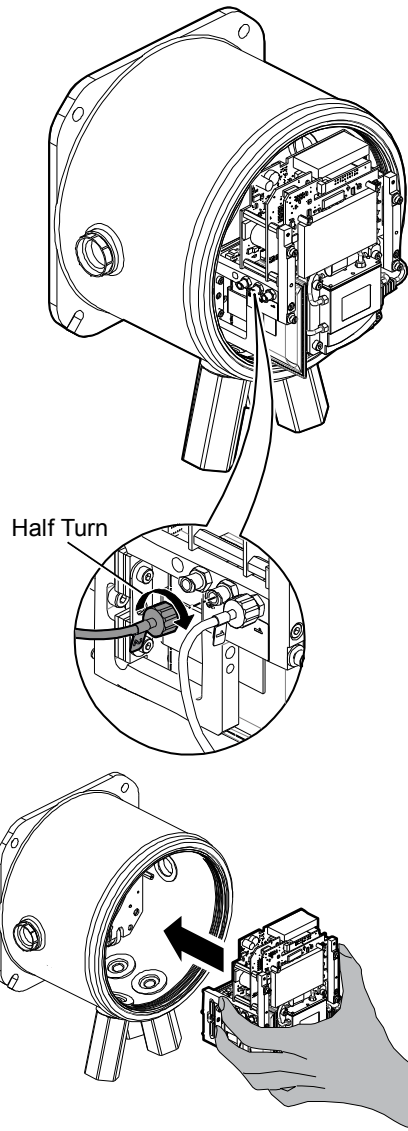

Check the identification of the pneumatic tubes and connectors.

Connect the tubes to the connectors: a half-turn, clockwise, of the Luer connectors will secure the pneumatic tubes:

- two on the left
- one on the right.

Ensure the tubes have no twists or kinks.

Hold the ribbon cable out of your way while you insert the Detection Module.

There are locating pins to ensure correct positioning of the Detection Module on the base-plate.

Move the module from side to side until it locks into place.

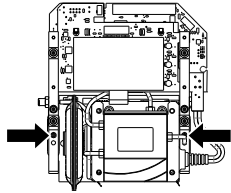

Use the allen-key to engage the captive screw at each side of the Detection Module.

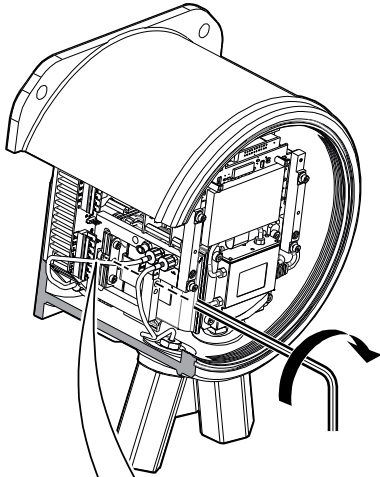

If the module is in its correct position, the screws will engage in the threads and turn freely.

If they do not engage the threads easily, check the position of the Detection Module.

Move the module from side to side until it locks into place.

Tighten them hand-tight.

Check the Detection Module is held firmly.

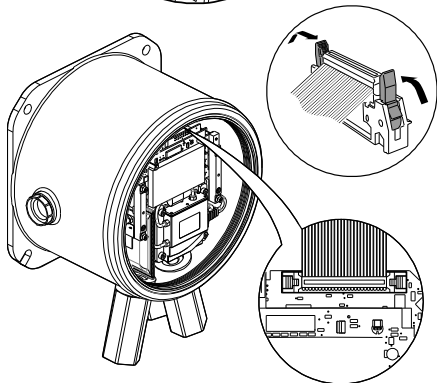
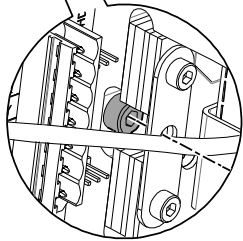

Attach the ribbon cable.

When you push it into its socket, it should clip in automatically.

Gently pull the cable to check it is securely connected.

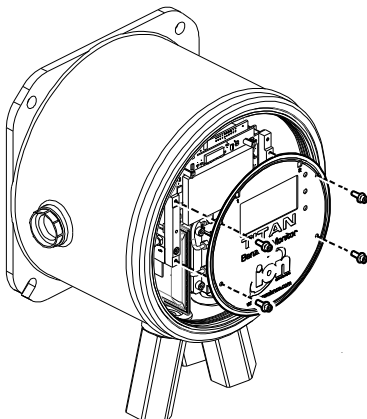

Use the four screws to attach the face plate. Tighten them firmly hand-tight.

USB Port

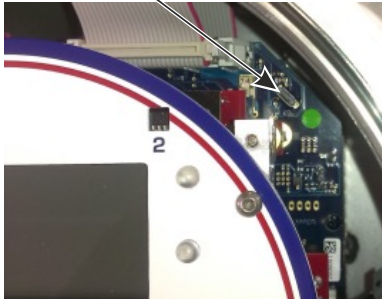

Connect a PC to the USB or RS485 connection and use TitanPC software to set the date and time. Refer to [Settings](#).

The date and time is used to "Date-stamp" all data files and calibration history.

Without external power, Titan can only store the current date and time for a maximum of 12 hours.

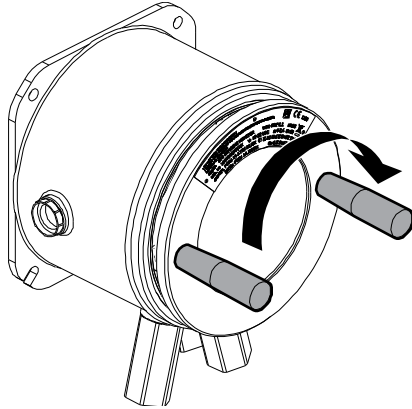

Install the front cover. Turn it clockwise until it is hand-tight.

CAUTION: Be careful to ensure the front cover engages easily with the screw thread. If there is resistance, remove it, examine it, and try again. Do not use force. Force can cause damage to the threads.

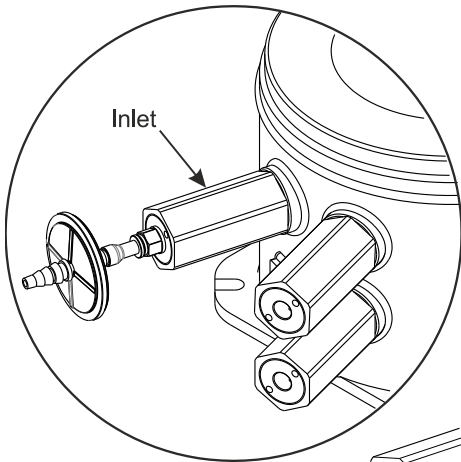

Ensure the external hydrophobic filter and any exhaust or inlet probe lines are connected.

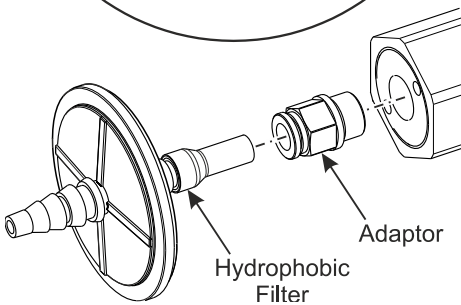

Switch on or connect the power supply.

Do an after-installation test. Refer to [After-Installation Test](#).

Operating the Titan

Switches and Display

The Titan front face has:

- An LCD display,
- two switches, magnetically operated,
- three LEDs.

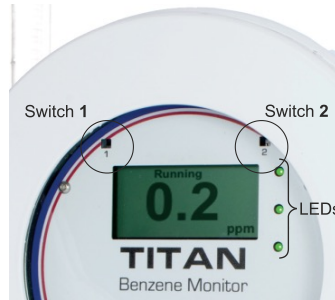

All three LEDs work together and display the same colour.

- LEDs Green Titan is operating correctly.
- LEDs Yellow Titan has an operational fault. An alert signal and the name of the fault is on the screen.
- LEDs Red The measured level of benzene is above the alarm threshold.

Power on

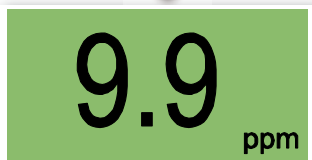
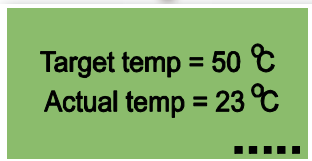

When power is turned on, the Titan displays the 'Ion Science' logo followed by the firmware version.

The Titan then starts to heat the AirSep filter. Normal operation cannot start until it reaches the target temperature. This will usually take a few minutes.

Normal operation starts when it is stable at the target temperature. The Titan then displays the ambient benzene level in parts per million (ppm). This updates once per minute.

Main screens and main menu

The actuation magnet supplied with the Titan operates the magnetic switches through the front cover.

On the main operation screen:

- Select Switch 2 to toggle between the current reading and the calculated STEL (Short-Term Exposure Limit) over the previous 15 minutes.
- Select Switch 1 to go to the main menu.

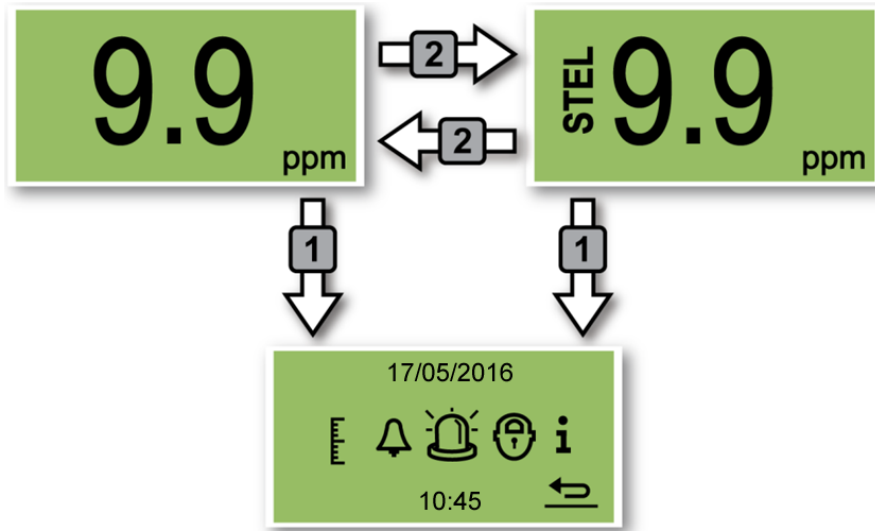

Menu Icons

	ICON ready to select or toggle		Return to previous screen		Information
	Calibration		Alarm Test		4-20mA comms system
	Alarm		Alarm 1		Alarm 2
	Lock		Unlock		Titan Display
	Relay		Relay 1		Relay 2

Navigation

The actuation magnet supplied with the Titan operates the magnetic switches through the front cover.

- Use Switch 1 to move to the next icon or value (options).
- Use Switch 2 to select an option or toggle between values.

The icon or value ready for selection is shown by an underline

Select the arrow to return the previous screens.

Calibration

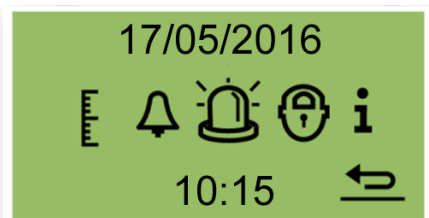

Select the Calibration icon to go the calibration menu.

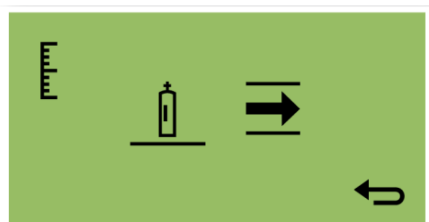

Select the bottle icon to go to the Benzene calibration screen.

Benzene Calibration

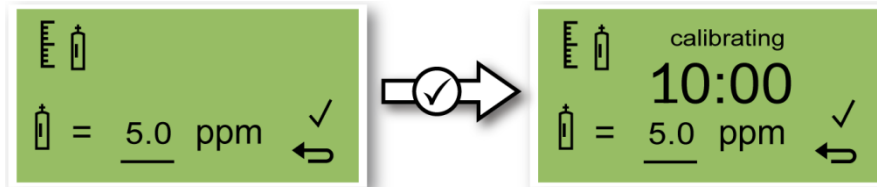

For accuracy over the full range; Ion recommends a bottle of 5ppm benzene. The software allows you to use any benzene concentration from 0.1 to 20.0ppm, if your application has different requirements.

Attach the bottle before you start calibration. This ensures the benzene is flowing through the Titan system before the start of the calibration.

Connect the bottle to the hydrophobic filter on the inlet flame-arrestor of the Titan. Use a demand-flow regulator that delivers more than 500mL/min. A fixed-flow regulator will not perform correctly and can damage the Titan.

Move the cursor to the ppm value. Use Switch 2 to cycle through the values to the benzene concentration of the bottle.

Select ✓ to start the calibration process.

Titan analyses the gas for a default time of 10 minutes.

You can select the return arrow icon to stop the calibration process at any time.

Once the timer has finished the new calibration will replace the previous calibration in the Detector Module.

Do a Bump Test to check the calibration. Refer to [Bump Test](#).

Flow Calibration

Ion recommends a bottle of between 5 and 10ppm benzene.

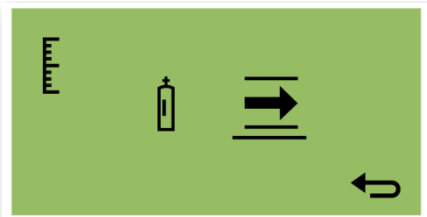

Select the flow arrow to go to the Flow calibration screen.



Attach the bottle before you start calibration. This ensures the benzene is flowing through the Titan system before the start of the calibration.

Connect the bottle to the hydrophobic filter on the inlet flame-arrestor. Use a demand-flow regulator that delivers more than 500mL/min. A fixed-flow regulator will not perform correctly and can damage the Titan.

Select ✓ to start the calibration process.

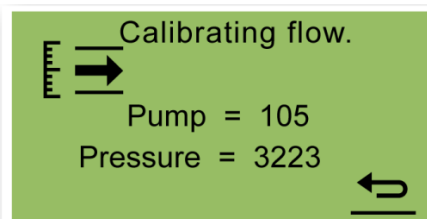

The calibration process lasts between 5 and 10 minutes.

You can select the return arrow icon to stop the calibration process at any time.

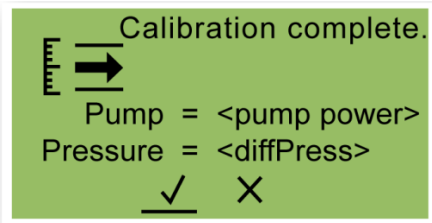

Calibration is complete and successful.

Select ✓ to **save** and return to the main menu. The new calibration will replace the previous calibration in the Detector Module.

Select X to **not save** and return to main menu.

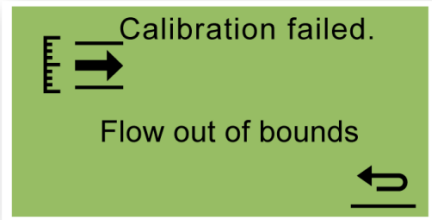

Calibration has failed for the reason shown on the screen.

Select the return arrow to return to the main menu.

If you can correct the fault, you can start the calibration again.

Do a Bump Test to check the calibration. Refer to [Bump Test](#).

Removal of the Memory Card

You can remove the memory card from the Titan. You can then connect the card to a PC and use TitanPC software to download and read the data.

While the Memory card is removed, the Titan cannot log data.



For safe removal of the memory card, use the magnet to actuate switch 1 for 5 seconds.

The Titan goes into safe mode. The Memory card removal screen shows when it is safe to remove the card.



When you remove the memory card, the arrows change direction to show that you must insert a card. Use the magnet to actuate switch 1 for 5 seconds to exit menu.

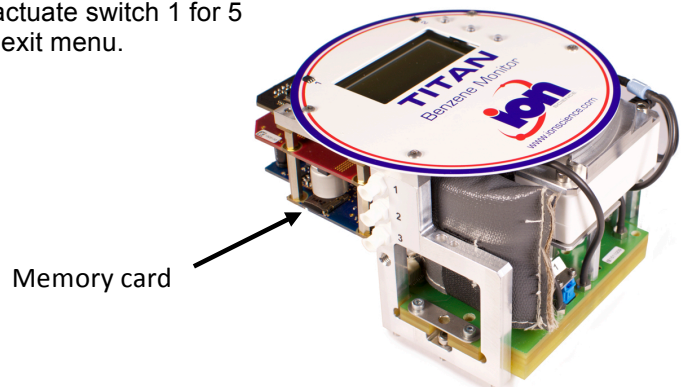
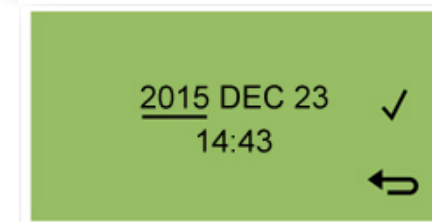

IMPORTANT: Fit the memory card before the service module is fitted into the EXD enclosure. The memory card is push to connect and push to release so may be pressed inadvertently during servicing. Always check the memory card is inserted correctly after servicing.

Password Lock

The password lock lets you:

- Prevent access to the calibration: so that selecting the calibration icon on the main menu will not access calibration menu.
- Prevent viewing of measured benzene levels: so the STEL and LIVE benzene displays will be blank.

You will use a 4-digit pin to turn the lock function on or off.

Titan is supplied with a default PIN of 0000 and with calibration and viewing unlocked.

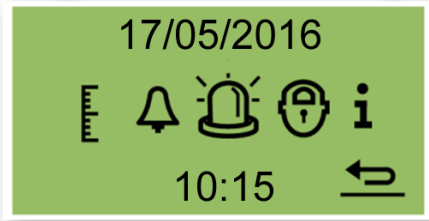

Select the lock icon on the main menu.

Lock the Calibration



On the "Lock Select" menu, select the calibration icon to lock or unlock the calibration screens.

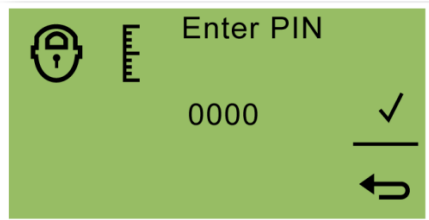

On the "Enter PIN" screen, use Switch 2 to cycle through the values to set the first digit. Use Switch 1 to move to the next digit.

The factory-set default is 0000.

When all the digits are set, Select ✓ to go to the "Lock/Unlock" screen.

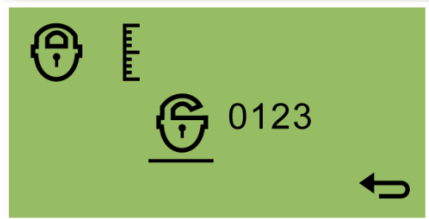

On the "Lock/Unlock" screen use Switch 2 to toggle between locking and unlocking the calibration.

Then select return to go to the "Lock Select" screen.

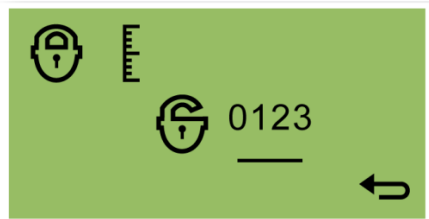

To change the PIN, use Switch 1 to navigate to the PIN number icon then use Switch 2 to select it.

This will take you to the "Enter new PIN" screen.

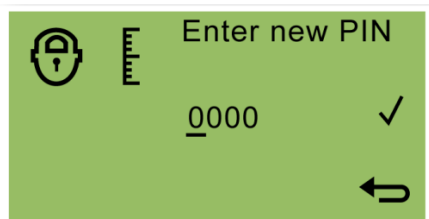

On the "Enter new PIN" screen, use Switch 2 to cycle through the values to set the first digit. Use Switch 1 to move to the next digit.

When all the digits are set:

- Select ✓ to save the PIN and return to the "Lock screen"
- Select ↩ to return to the lock screen without saving the PIN.

Lock the STEL and LIVE Displays



On the "Lock Select" menu, select the Titan Display icon to prevent or allow viewing the STEL and LIVE values on the screen.

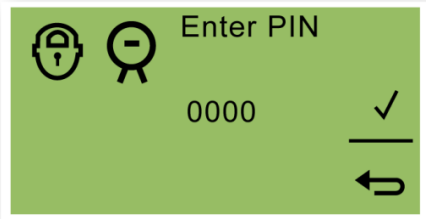

On the "Enter PIN" screen, use Switch 2 to cycle through the values to set the first digit. Use Switch 1 to move to the next digit.

The factory-set default is 0000.

When all the digits are set, Select ✓ to go to the "Lock/Unlock" screen.



On the "Lock/Unlock" screen use Switch 2 to toggle between locking and unlocking the display.

Then select return to go to the "Lock Select" screen.

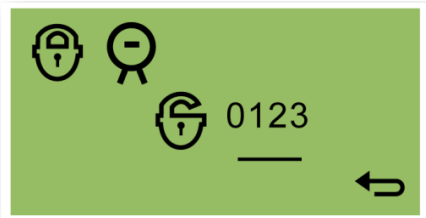

To change the PIN, use Switch 1 to navigate to the PIN number icon then use Switch 2 to select it.

This will take you to the "Enter new PIN" screen.



On the "Enter new PIN" screen, use Switch 2 to cycle through the values to set the first digit. Use Switch 1 to move to the next digit.

When all the digits are set:

- Select ✓ to save the PIN and return to the "Lock screen"

Select  to return to the lock screen without saving the PIN.

Alarms and Relays

The alarms and relays are individually programmable to the settings required by the site policy. You can choose either alarm to energize either relay. The default settings would be. When the Titan is not powered the default state of relay 1 is N/C, the default state of relay 2 is N/O.

- Alarm 1: 5.0ppm live
- Alarm 2: 0.5ppm STEL
- Relay 1: Alarm 1, N/O
- Relay 2: Alarm 2, N/O

Both relays can be programed to be Normally Open or Normally Closed.

Alarm or Relay Selection

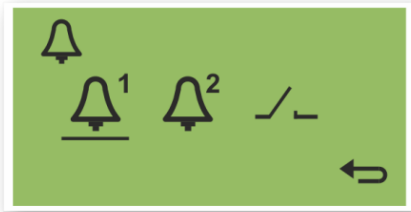

Select:

- Alarm 1
- Alarm 2
- Relays

That takes you to the configuration screen for that item.

Alarm Configuration

The configuration procedure for Alarm 1 is shown. Alarm 2 is the same.



Toggle between:

- STEL
- LIVE

Move the cursor to the value.

Use Switch 2 to cycle through the values to the target value.

STEL:

Alarm starts when the STEL concentration is equal to or greater than target value.

LIVE:

Alarm starts when the current concentration is equal to or greater than target value.

-- ppm:

The target value concentration.

Relay Configuration

This menu lets you set which relay each alarm operates and whether the relay is normally open (NO) or normally closed (NC).

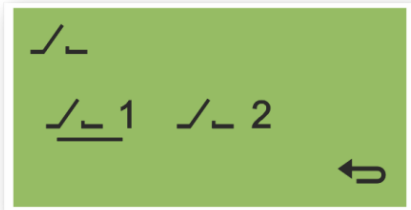

Select Relay 1 or Relay 2.

That takes you to the configuration screen for that relay.

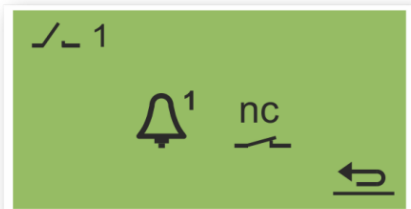

Select the Alarm Icon.

Toggle between:

- Alarm 1
- Alarm 2
- Instrument FAULT.

Select the contacts Icon.

Toggle between NO and NC.

Relays and 4-20mA Test

Do a test of the relay and the 4-20mA systems to check for correct installation and function.

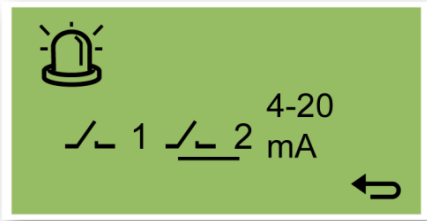

Select Relay 1, Relay 2 or 4-20mA.
That takes you to the test screen for the relay or 4-20mA system.

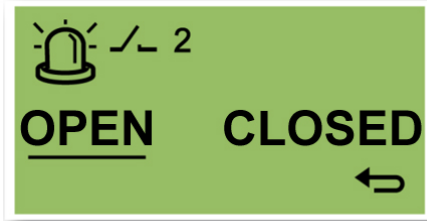

On the Relay test screen, toggle between OPEN and CLOSED to manually operate the relay.

When you return  to the previous screen, the system returns to normal operation.

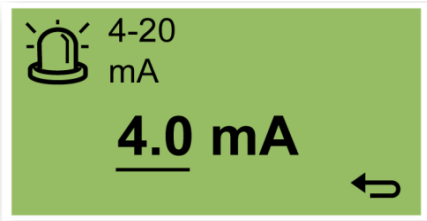

On the 4-20mA test screen, use switch 2 to cycle through the output values. The 4-20mA output changes to the value displayed.

When you return  to the previous screen, the system returns to normal operation.

Information Pages

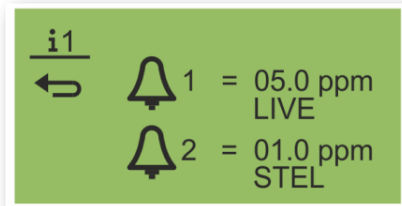

Information Page 1

Alarm 1 configuration settings
Alarm 2 configuration settings

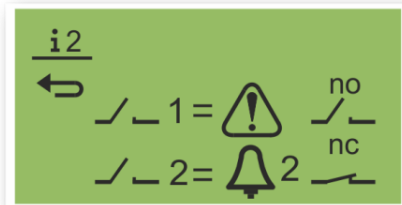

Information Page 2

Relay 1 configuration settings
Relay 2 configuration settings

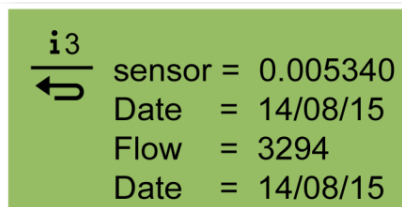

Information Page 3

Sensor calibration value
Sensor Calibration date
Flow Calibration value
Flow calibration date

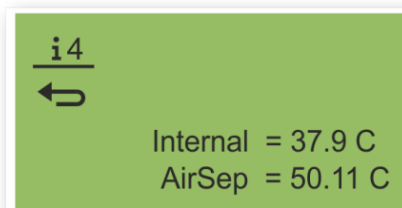

Information Page 4

Titan internal temperature
AirSep temperature

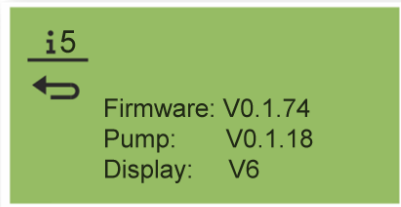

Information Page 5
 Firmware version number
 Pump Driver Board Version Number

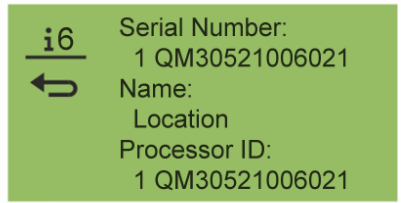

Information Page 6
 Instrument serial number
 User settable location
 Processor serial number

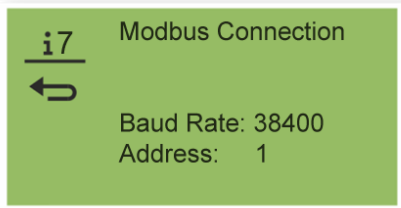

Information Page 7
 Baud rate
 Modbus address

Fault Indications



If there is a fault:

- The three LEDs show Yellow
- The main screen changes to a - Warning Screen and gives the name of the fault at the bottom. Use the Fault Name to find information from the Fault Diagnostics section of this manual.

Alarm Indications



If the benzene level exceeds one of the two target concentration values selected during Alarm Configuration:

- The three LEDs on the front panel show red.
- An alarm symbol and the alarm number, is displayed in the top right of the screen.
- If a relay is associated with the alarm, it is energized.
- Benzene detection continues.
- The alarm is only raised if the current cycle is above the alarm thresholds.

Service Period Reminder

Titan counts continuous days of operation. When it reaches 180 days:

- The screen changes to "Service Required"
- The three LEDs on the front panel show yellow.

Only a Service Center can reset it.

TitanPC Software

The TitanPC software lets you connect to the Detection Module to:

- Calibrate the module
- View and download the detection and fault histories stored in the module
- Set the operating thresholds of the alarms and relays
- Adjust the time and date settings in the module clock
- Give the module an identification appropriate to its installation
- Upgrade the operating firmware on the module.

Minimum requirements

TitanPC Software works on PCs or laptops with operating systems:

- Windows XP (no longer supported),
- Windows Vista
- Windows 7
- Windows 8 / 8.1

Installation

The software is supplied by Ion Science Ltd on a USB memory stick. Or the latest version can be downloaded from the Ion Science Website.

1. Insert the memory stick in the PC.
2. Click on the TitanPC.exe file.
3. Follow the onscreen instructions.

Connect the Titan to the PC

1. Install the Detector Module into the Test Housing Module.
2. Connect the USB or RS485 output to the PC.
3. Connect or switch on the power supply.
4. Start TitanPC.







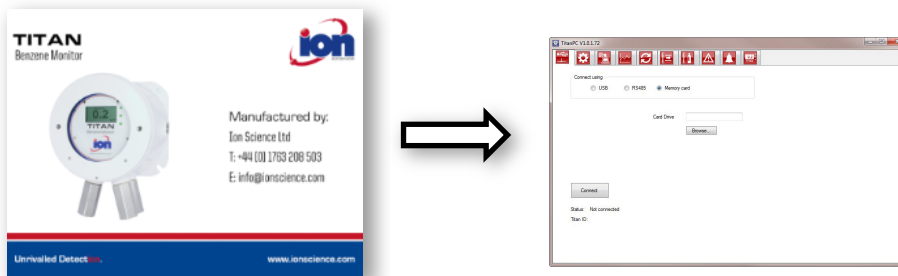



Starting the Software

After installation, click on the TitanPC icon  on the desktop to start the software.

TitanPC shows a start-up window while loading the software, then the Main Operation Window when ready for use.



TitanPC shows ten icons at the top of the window. Click on an icon to see the window you want.

- | | | | |
|---|------------------|---|-------------------------------|
|  | Connection |  | Benzene Calibration |
|  | Settings |  | Fault Log |
|  | Data Download |  | Alarm and Relay Configuration |
|  | Upgrade |  | Data View |
|  | Flow Calibration |  | Virtual Display |

Data Connection



Click the  icon for the Connection window.

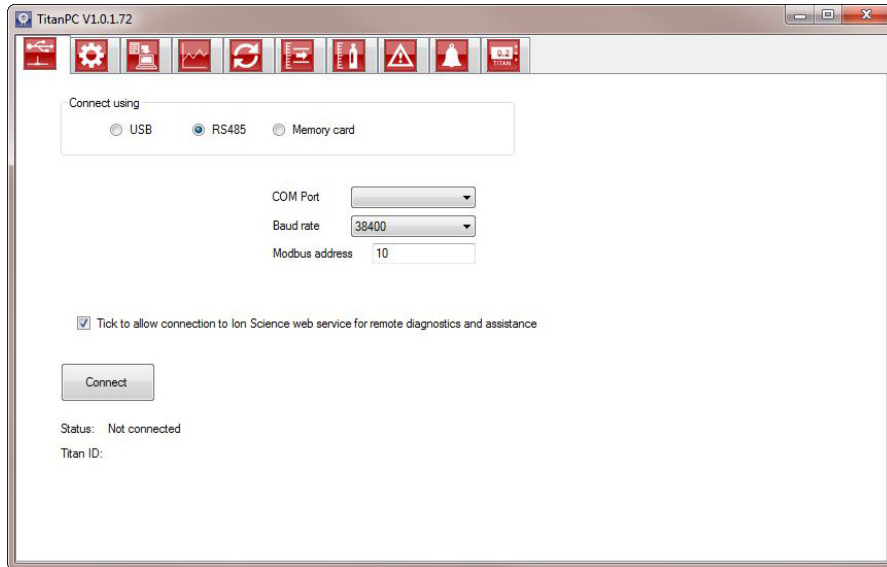

Click on the radio button for USB or RS485, to select the connection type.

- RS485 is normally used when the Test Housing Module is a permanent installation. The default address of the Titan is 10.
- USB is normally used for a bench-top set-up or connect a PC/Laptop to a Detector Module in its normal, installed position.

Click on the "Connect" button to manually connect to the Titan.

If connection is successful, it will show the status and ID of the Titan.

Or you can remove the memory card from the Titan (Refer to [Removal of the Memory Card](#)) and insert it into the pc. Then select Memory Card and click Browse to find the card location. After connection, you can download and view the data on the card.

If Titan is connected via USB, and the PC is connected to the internet, you can tick the check-box to allow Ion Service Support to remotely connect to the Titan to view factory level data and configuration values.

Settings



Click the  icon for the Settings window.

The software should automatically scan for data when started. The "Read from Titan" button lets you manually scan for data, if necessary.

When the software has successfully connected to the Titan, the serial number, instrument name and instrument date and time are displayed.

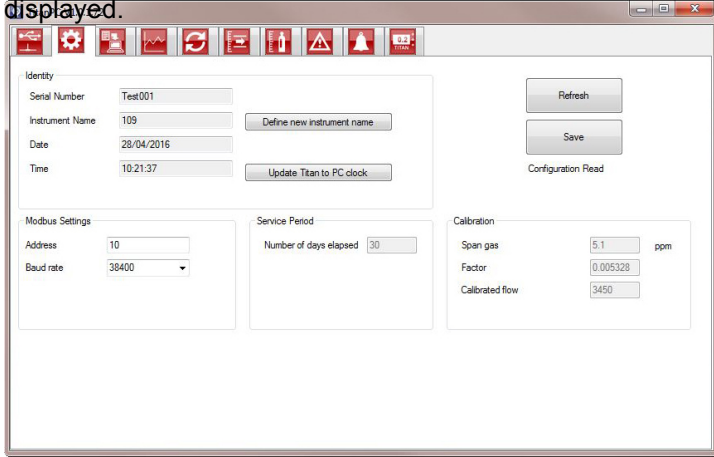

You can change the instrument name to something more meaningful (for example, 'Area 1 Monitor').

You can change the Titan date and time to the same as the PC clock.

Modbus: Change address and baud rate

Service period: Displayed in days since last service

Calibration value: Test gas concentration, sensor calibration factor and flow calibration factor

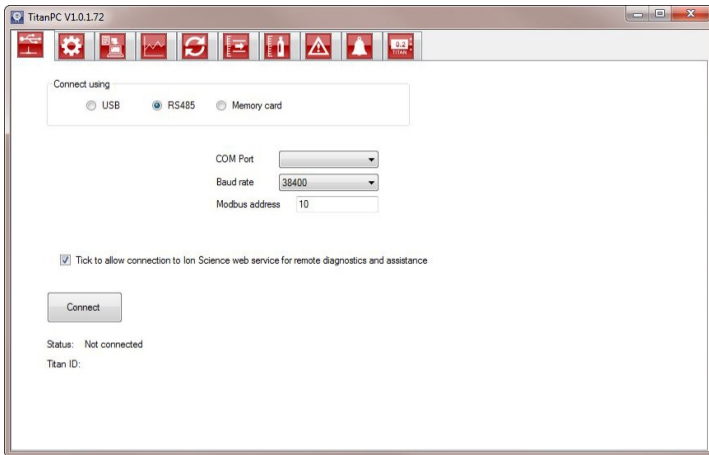

Note:

1. The Titan internal clock is automatically set during calibration using TitanPC. Without external power, Titan can only store the current date and time for a maximum of 12 hours.

Data Download



Click on the  icon for the Data Download window.

When data is available to download, a list of the available dates is displayed under "File Date" on the left.

If necessary, click "Refresh" to scan the instrument for fresh data.

Click on the available dates to select the data you want.

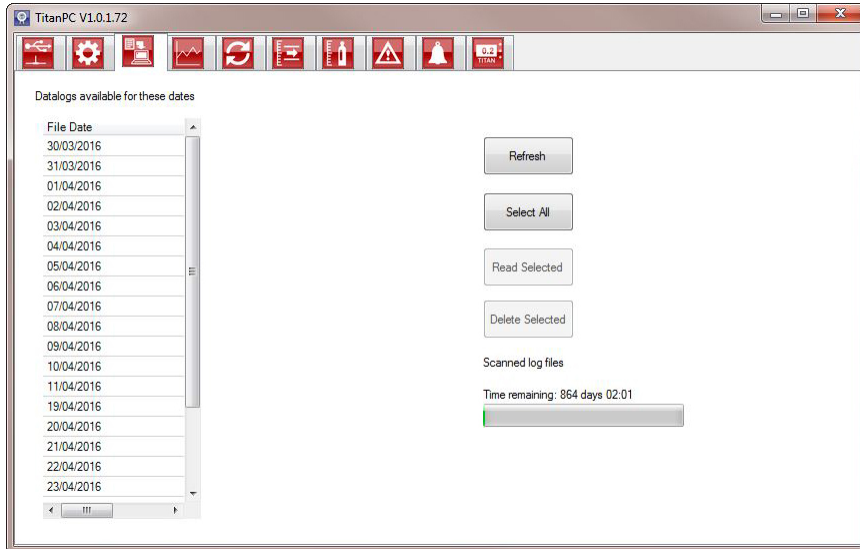

Use standard windows functions to select groups of dates, e.g.:

- For consecutive files click the first one, hold down the Shift Key [Shift] and click on the last file you want.
- For non-consecutive files, hold down the Control Key [Ctrl] and click on each file you want.

Or click the "Select All" button if you want all the files.

After selecting the files:

Click "Read Selected" to download the files to the PC

Click "Delete Selected" to delete the files.

The bar at the bottom of the screen indicates how much memory is used/unused in the Titan.

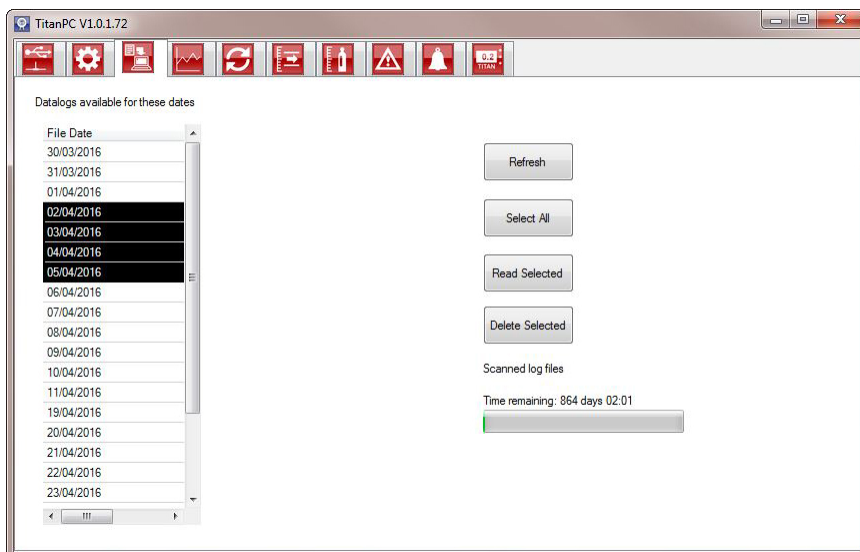

Data View



Click on the icon for the Data Download window.

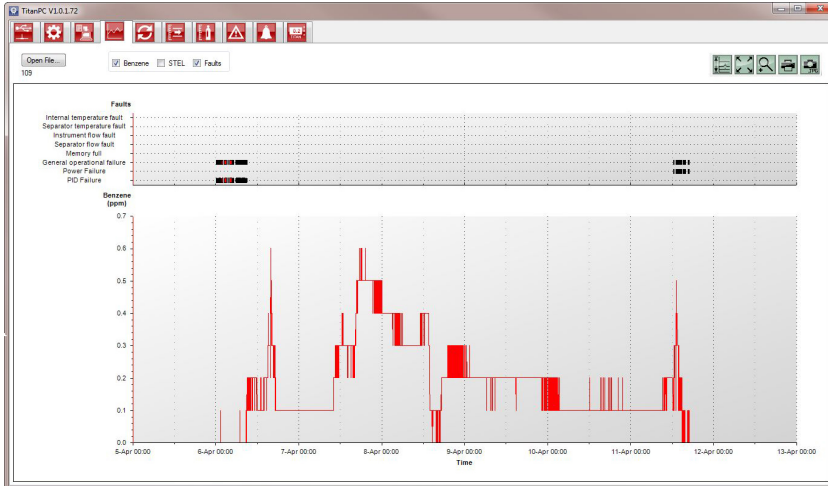

Data View allows you to view, print or save pictures of graphs of the data in files downloaded from Titan using Data Download. You can change the presentation to how you want to see it.

Click the 'Open File' button and select a file from the list.

TitanPC shows the data as a graph, or graphs superimposed on each other using the same time-axis. Each data-set has its own, colour-coded, axis on the left. Fault groups (refer to [TitanPC Fault Groups](#)) are shown in a bar-graph at the top of the screen.

The tick-boxes at the top let you choose which graphs you see.

Hold down the left mouse button to grab and drag the graph around the screen. Use the mouse wheel to zoom in and out.

There are 5 control buttons at the top right of the screen:



Scales – adjustment of data-axis scales.

Click on this to manually adjust the axis of each data-set.

In the pop-up window, click on the arrows, or type-in numbers to change the maximum and minimum values of the scale. Click the 'Auto Scale' button to revert to the default values.



Zoom to fit (Auto-scale).

Click this to reset the graph to make all data visible (Auto-scale).



Zoom.

Click this to zoom-in on an area of the graph. The cursor changes to a magnifying glass when over the graph. Hold down the left mouse button to draw a rectangle around the area you want to enlarge. Click the Zoom button again to leave zoom mode.



Print.

Click this to print the view you have on the screen.



Save as a Picture.

Click this to save the view you have on the screen, as a picture. You can save in jpg, emf, bmp, tif, png, or gif format.

Upgrade



Click on the  icon for the Upgrade window.

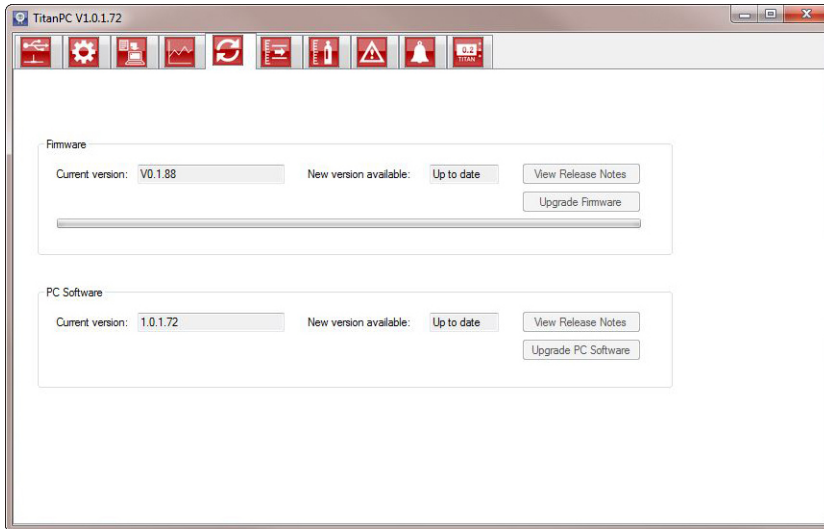

If the PC is connected to the internet TitanPC will automatically detect if a new version of firmware or software is available.

If new firmware or software is available, you can view the release notes or do an upgrade.

Flow Calibration



Click on the icon for the Flow Calibration window.

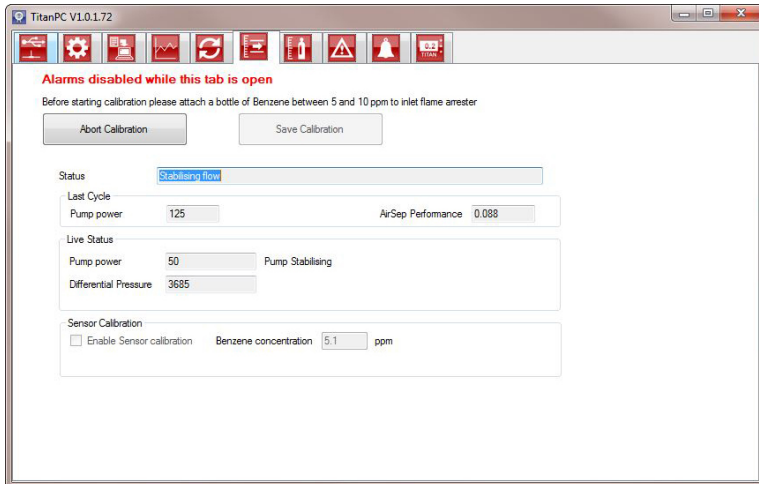

Attach a bottle of between 5 and 10ppm Benzene to the inlet flame-arrestor before you start calibration. This ensures the benzene is flowing through the Titan system before the start of the calibration.

Click the "Start Calibration" button. The text on the button will change to "Abort Calibration." You can click the button again to any time to stop the calibration and reset the screen to its original state.

"Last Cycle" shows the pump power and AirSep Performance value for the previous cycle.

If the AirSep Performance value is larger than the specified configuration value then the calibration will fail.

"Live Status" shows the applied pump power and measured differential pressure of the current cycle. If the pump cannot run between the limits of 'Minimum Pump Power' and 'Maximum Pump Power' then the calibration will fail.

"Sensor Calibration" If you tick "Enable Sensor Calibration" and type-in the Benzene concentration of the bottle, TitanPC will calibrate the sensor after the Flow Calibration.

The "Save Calibration" button is not active until the calibration is complete and successful. The new calibrated flow will not replace the old setting in the Detector Module until you click the button. The text "Calibration Saved" will then appear next to the button.

The Status, Pump power and Differential pressure stay on the screen until you start a new calibration.

Do a Bump Test to check the calibration. Refer to [Bump Test](#).

During the procedure the **"Status"** message shows:

"Instrument ready"	When there is a Detector Module connected to TitanPC.
"Stabilising flow"	When the pump power has been adjusted and the software is waiting for stable flow conditions.
"Running measurement cycle"	When the software is doing a measurement cycle.
"Calibration successful"	When the calibration is complete and successful.
"Calibration failed: AirSep fault"	When the calibration diagnoses a failure of the AirSep.
"Calibration failed: pump power high"	When calibration diagnoses that the pump power required for a working flow is too high.
"Calibration failed: pump power low"	When calibration diagnoses that the pump power required for a working flow is too low

Benzene Calibration



Click on the icon for the Benzene Calibration window.

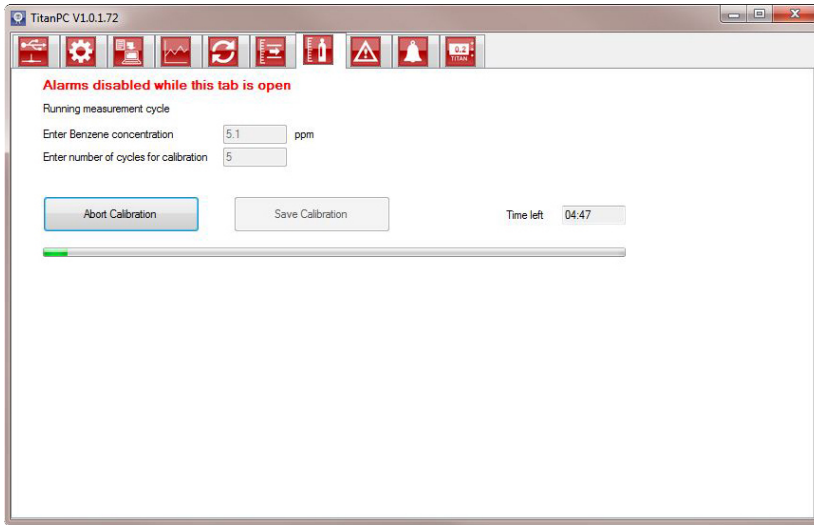

Ensure the Detector Module clock is set to the correct date and time.

Ensure the flow is successfully calibrated before you do Benzene Calibration.

For accuracy over the full range; Ion recommends a bottle of 5ppm benzene. The software allows you to use any benzene concentration from 0.1 to 20.0ppm, if your application has different requirements. Titan analyses the gas for a default of 5 cycles (10 minutes). If the tube or inlet probe between bottle and Titan is long, you can increase the cycles to ensure a stable gas flow. (Contact Ion Science or your Service Center)

Attach the bottle before you start calibration. This ensures the benzene is flowing through the Titan system before the start of the calibration.

Connect the bottle to the hydrophobic filter on the inlet flame-arrestor of the Titan. Use a demand-flow regulator that delivers more than 500mL/min. A fixed-flow regulator will not perform correctly and can damage the Titan

Type-in the benzene concentration of the bottle and the cycles required.

Click on the "Start Calibration" button.

The screen shows the "Time Left" and the progress bar at the bottom.

At the end of the calibration the option to "Save" will show on the screen. The new calibration will not replace the previous calibration in the Detector Module if you do not click the Save button.

Do a Bump Test to check the calibration. Refer to [Bump Test](#).

Recorded Faults



Click on the icon for the Recorded Faults window.

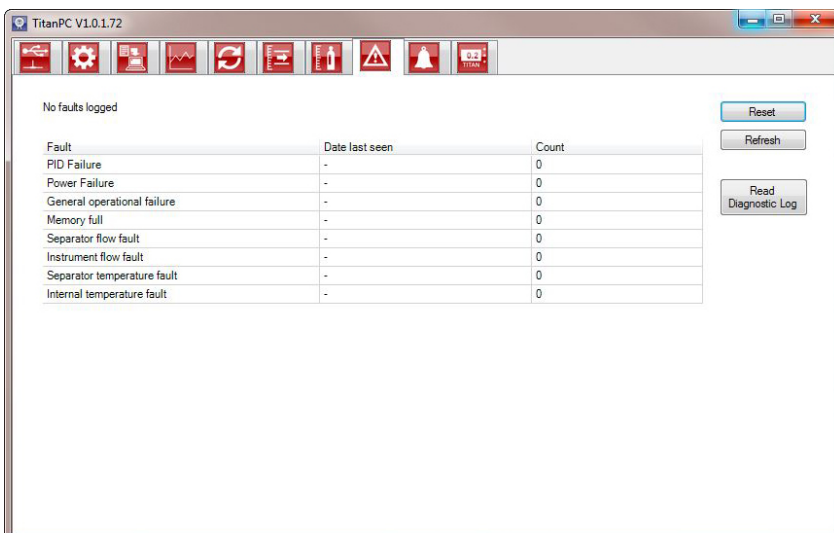

This screen shows the last date a fault occurred and how many times it has occurred.

Click "Refresh" to scan for the latest fault data.

Click "Reset" to clear all the fault reports to zero.

For more details of the fault conditions, refer to the [Fault Diagnostics](#) section of this manual.

Pressing the 'Read Diagnostic Log' button opens the following screen. The diagnostic file and comments can be sent to Ion Science or to an e-mail of the user's choice.

The screenshot shows a standard Windows-style email composition window titled "Email Ion Science Ltd.". The window contains the following elements:

- Your email address (to allow us to reply - optional):** An empty text input field.
- Clear form:** A button located to the right of the email address field.
- Instrument number:** A text input field containing the value "Test001".
- Additional files to send:** A large empty rectangular area for file attachments.
- Add file...:** A button to the right of the attachment area.
- Remove file:** A button to the right of the attachment area.
- Subject:** A text input field containing the value "Fault log from Test001".
- Please add any comments you wish to send:** A large empty text area for the email body.
- Confirmation:** A checkbox at the bottom left with the text "I confirm that I am sending data to Ion Science Ltd and am happy for Ion Science Ltd to use that data".
- Buttons:** "Cancel" and "Send" buttons at the bottom right.

Alarm Set



Click on the  icon for the Alarm Set window.

You can set each alarm to operate when the STEL or Current level of Benzene reaches a set value in ppm.

- In the window, type the value to trigger the alarm.
- Click on the radio button to choose STEL or Current value as the trigger.

You can select which alarm or fault will operate each relay and whether it is normally open NO or normally closed NC.

For each relay select between:

- Alarm 1
- Alarm 2
- Instrument FAULT.

Select the contacts as NO or NC.

Click "Refresh" to reset the screen to the values in the Titan.

Click "Save" to set the Titan to the values on the screen.

Virtual Screen



Click on the  icon for the Virtual Screen window.

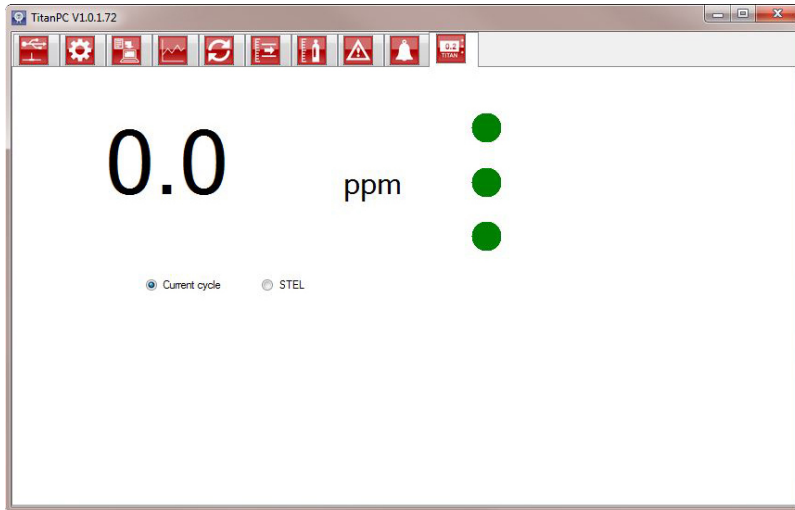

This tab displays in real time what is displayed on the Titan screen. A radio button allows the user to switch between the current cycle reading and the calculated STEL.

Bump Test

A "Bump Test" is not a calibration. The test verifies that the Titan is accurately measuring benzene at a known concentration supplied from a bottle.

Use of the Test

Ion Science Ltd. recommend you do a Bump Test:

- After initial installation.
- After replacement of a Detector Module.
- Once per week. Or at a regular period specified by the installation site policy.
- If the Titan is exposed to a high gas concentration.
- If the Titan receives a large physical shock.
- If the Titan is exposed to silicone poisons.

Test Procedure

Ion Science Ltd recommended you use a bottle of 5ppm benzene equipped with a demand-flow regulator delivering more than 500mL/min. A fixed-flow regulator will not perform correctly and can damage the Titan.

You can use any concentration from 0.1 to 20.0ppm benzene, if your application has different requirements.

Connect the bottle to the hydrophobic filter on the inlet flame-arrestor. Allow 3 minutes for the reading on the Titan display to stabilize.

If the Titan does not display the gas concentration given by the bottle, calibrate the Titan to give the correct readings. Refer to:

- On-board [Benzene Calibration](#)
- On-board [Flow Calibration](#)
- TitanPC [Benzene Calibration](#)
- TitanPC [Flow Calibration](#)

Manually energize the relays and 4-20mA system to verify correct connection of the systems. Refer to [Relays and 4-20mA Test](#).

Fault Diagnostics

Fault and Alarm indications



If there is a fault, the main screen changes to a Warning Screen and gives the name of the fault under the warning icon.

Use the Fault Name in the table below to find the possible conditions causing the fault.

Fault Conditions

The Titan is equipped with a number of diagnostics to ensure instrument faults are detected and communicated. The table gives a fuller description of each fault and list some possible causes and corrective actions you can try.

If the fault continues, or is repeated, contact your Service Center.

Abbreviations:

CTO = Continues to Operate. (Titan continues to operate but results might not be correct.)

Norm = Normal Operation

Fault Name and Description	Possible Causes and Corrective Actions	4-20mA signal	LED colour	CTO
Service Required: The Titan requires its 6-month service check.	Titan has recorded 180 days of continuous operation without a service. This can only be reset by an Ion Science Service Center.		Yellow	Yes
Temp error: Ambient temperature too high. or AirSep temperature out of limits.	Ambient temp >50, Try cooling or shading the Titan to prevent overheating. AirSep temp <45 or >80 Or failed to reach temp within 180 mins, Possible thermocouple fault. Contact the Service Center.	2.000	Yellow	Yes
Temp fault: Instrument temperature too high for extended period.	Ambient T >50 for 1 hour Try cooling or shading the Titan to prevent overheating.	2.125	Yellow	Yes
Sensor flow low: AirSep flow too low.	Check for kinks or pinches in the tube between port 3 and the inlet flame-arrester.	2.250	Yellow	Yes
Sensor flow high: AirSep flow too high.	Check that AirSep filter is pushed in firmly and internal tube connections are not loose. Recalibrate the flow.	2.375	Yellow	Yes
Outlet Blocked: Reduced flow through the outlet flame-arrester.	P3 values not correct. Check for kinks or pinches in the tube between port 4	2.500	Yellow	Yes

Fault Name and Description	Possible Causes and Corrective Actions	4-20mA signal	LED colour	CTO
	and the outlet flame-arrester.			
Tube off: Increased flow through the inlet flame-arrester.	P3 values not correct. Check for leaks between the external (Hydrophobic) filter and the inlet flame-arrester. Check for leaks between the external (Hydrophobic) filter and the extended probe line, if installed. Check for any disconnected tubes within the Detector Module.	2.625	Yellow	Yes
Inlet Blocked: Reduced flow through the inlet flame-arrester.	P3 values not correct. Check the external (Hydrophobic) filter is not blocked. Check the extended probe line, if installed, is not blocked or kinked. Check the inlet flame-arrester for damage or blockage. Check for kinks or pinches in the tubes within the Detector Module.	2.750	Yellow	Yes
Lamp Out: No signal from PID Light sensor.	PID Lamp not illuminated. Sensor failure. During Titan start-up, wait at least 5 cycles for the lamp to illuminate.	2.875	Yellow	Yes
Memory full: Not enough memory space to store history.	Memory full. Use TitanPC to download or delete History Record Files.	Norm	Red	Yes
PID ADC Fail: Communication failure	Internal hardware fault. Remove the Detector Module to check that the black wiring loom is connected and not damaged.	3.000	Yellow	Yes
Step overrun: Internal hardware fault	Program code step took more than 0.5s to execute. Contact the Service Center.	Norm	Red	Yes
Step error: Software fault.	Invalid sequence step. Contact the Service Center.	Norm	Red	Yes
Watchdog:		3.125	Red	Yes

Fault Name and Description	Possible Causes and Corrective Actions	4-20mA signal	LED colour	CTO
Software fault.	Software fault. Contact the Service Center.			
Pump fault: Failed communication with pump board.	Internal hardware fault. Contact the Service Center.	3.250	Yellow	Yes
Pump power fail: Pump power fault.	Pump board power failure. Contact the Service Center.	3.375	Yellow	No

TitanPC Fault Groups

To reduce file size and memory usage, fault records are grouped together in the files stored on the Titan and downloaded to the TitanPC.

TitanPC Group Name	Faults in the Group
PID failure	Lamp out, PID ADC fail
Power failure	Pump power fail
General Operational failure	Step overrun, Watchdog, Pump fault, Step error
Memory full	Memory full
Separator flow fault	Sensor flow high, Sensor flow low
Instrument flow fault	Outlet blocked, Inlet blocked, Tube off
Separator temperature fault	Temp error
Internal Temperature fault	Temp fault

Parts List

Part	Description	Part number	Qty
Titan 875 Benzene Monitor and Accessories Kit	Installation Kit, Comprising:	TNXSXBXX-X	
	Housing Module	A-875281	1
	Detector Module	A-875245	1
	Front Cover Removal Tool	875413	2
	Transit Strap	875400	1
	Transit Strap Screws (M10x16)	2/SH10-16	2
	Switch Actuation Magnet	A-875265	1
	External (Hydrophobic) Filter	A-875417	1
	Gland Port Plug (for transportation)	4/PB-05	2
	Allen Key 2mm	4/TA-06	1
	Allen Key 3mm	4/TA-08	1
	Mounting Template	875431	
	Titan User Manual	875263	1
Titan Detector Module and Accessories Kit	Detector Module as spare, or for off-site service or calibration Comprising:	TSMXSXXXX-X	
	Titan Detector Module	A-875245	1
	Transit Case	875405	1
	Front Cover Removal Tool	875413	2
	Allen Key 2mm	4/TA-06	1
	Allen Key 3mm	4/TA-08	1
Titan Calibration Gas Kit	Comprising:	861517	
	Bottle of 5ppm Benzene		1
	Carry case		1
	Tubing		1
	Demand-flow Regulator		1
Faceplate (Enhanced EMI protection)	Alternative Faceplate with increased protection against Electromagnetic Interference	875294	
Transit Case	For transporting the Detector Module without the Housing Module	875405	1
Cover Removal Tool	Tools to remove the front cover	875413	2
Actuation Magnet	Tool to operate the magnetic switches	A-875265	1

	through the front cover			
External (Hydrophobic) Filter	Replacement External Filter	A-875417	1	
Allen Key 2mm	Ball-ended Hex Wrench To remove Detector Module	4/TA-06	1	
Allen Key 3mm	Ball-ended Hex Wrench To remove Detector Module	4/TA-08	1	
TitanPC Software	To use a PC to calibrate and download detection and fault history (on USB stick or Ion website)			
Titan User Manual	Installation, Operating, Servicing and Fault Diagnosis Instructions	875632	1	

Manual Log

Manual Version	Amendment	Issue Date	Instrument Firmware	PC software
1.0	First Issue	01/01/2016	0.1.70	1.0.1.54
1.0	Cover - Tian image Page 6 - Declaration of conformity Page 7 - Statements Page 8 - US office address Page 12 - Warning notice Page 29 - Added graphic page 29 Page 36, 38 - Modified graphics Page 39 - Added memory location image Page 40,43, 44 - Modified / added graphics Page 47 to 59 - Replaced screen graphics			