

EX90-Series

Electromagnetic Insertion
Flow Sensor



For Sales & Service Contact

geotech

2650 E. 40th Ave. • Denver, CO 80205
Phone 303-320-4764 • Fax 303-322-7242

1-800-833-7958

www.geotechenv.com



General Information

General Information Page 3
 Features Page 3
 Specifications Page 4
 Flow Rate Page 4
 Dimensions Page 5

Installation

Chemical Injection or Fertigation Page 6
 Fitting Installation Page 6
 Meter Installation Page 6
 Saddle Installation Page 7
 Straight Pipe Recommendations Page 8
 Full Pipe Recommendations Page 9

Connections

General Cable Information Page 10
 Cable Gland Opening and Sealing Page 10
 Cable Installation Page 10
 Wiring Diagrams Page 11
 Cable Wiring Table Page 11

Configuration

Cable Shield Page 12
 Pulse Output Page 12

Operation

Minimum Flow Page 13
 Filtering Page 13
 Electrode Coating Page 13
 Changing Flow Meter Settings - Standard Menu Options Page 13
 Changing Flow Meter Settings - Submenu Page 13
 Changing Flow Meter Settings - Home Screen and General Navigation Page 15
 Changing Flow Meter Settings - Making Selections Page 15
 To Change a Passcode Page 16
 Power Indicators Page 16
 Battery Powered Units Page 17

Troubleshooting & Error Messages

Problem Page 18
 Probable Cause Page 18
 Things to Try Page 18
 Error Messages Page 19

The **EX90-series** battery powered, insertion electromagnetic flow meter is designed for use with conductive fluids in 4"–12" pipe. The EX90's stainless steel body allows the meter to operate in a wide range of temperatures, pressure, and corrosive or dirty environments.

The EX90 is highly suitable for difficult applications. With no moving parts, these meters can be used in "dirty water" applications where debris would foul a mechanical meter. If the EX90 meter is used with a programmable controller, the output signal can be fed direct, with no other conditioning required.

Rate and total units can be set via the front panel touch key pad by the user.

Bidirectional flow is standard with totals available in forward, reverse, net, batch forward and batch reverse.

The EX90 is battery powered with an output cable available for transmitting the pulse signal to remote devices. The EX90 can be ordered with a saddle or weld fitting designed to accommodate a wide range of pipe sizes and types while ensuring correct placement in the pipe. In addition, an optional internal data logger allows local storage of flow history.

The EX90 is also ideal for replacement of mechanical style propeller meters.

Features

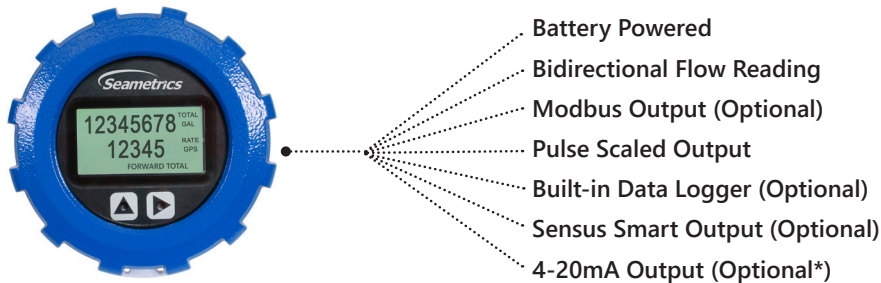

Quickly and easily change Total Volume Units, Flow Rate Units, Pulse Output Scaling, and many other settings using the two light sensor button controls on the display panel.

Flow Rate (4" - 12")

Nominal Pipe Size	4"	6"	8"	10"	12"
Low Flow Cutoff GPM	19.3	43.11	77.1	120.5	173.5
Low Flow Cutoff LPS	1.22	2.72	4.86	7.6	10.95
Min GPM	64.3	144.6	257	401.6	578.3
Min LPS	4.1	9.1	16.2	25.3	36.5
Max GPM	578	1301	2313	3614	5204
Max LPS	36.5	82.1	145.9	228	328.3

Specifications*

Pipe Size	4" to 12"			
Materials	Sensor Body	316 SS		
	Electrodes	Hastelloy		
	Housing	Powder-coated diecast aluminum		
	Electrode Cap	PVDF (Kynar®)		
	O-Ring	EPDM		
Temperature	Operating	10° to 140° F (-12° to 60° C)		
	Storage	-40° to 158° F (-40° to 70° C)		
	Fluid Temp.	32° to 200° F (0° to 93° C)		
Pressure	200 psi (14 bar)			
Flow Rate	0.5 - 4.5 m/sec (1.64 - 14.8 ft/sec) (Low flow cutoff .15 m/sec; .49 ft/sec)			
Calibration Accuracy	0.5 - 4.5 m/s (1.64-14.76 ft/sec)	+/- 2% of reading		
	0.3 - 0.5 m/sec (0.98 - 1.64 ft/sec)	+/- (2% of reading + 0.25% of full scale)		
Display	Type	128x64 dot-matrix LCD		
	Digits	5 Digit Rate	8 Digit Total	
	Units	Rate Volume Units	Rate Time Units	Total Volume Units
	<i>Please Note: All meters are factory set for gallons per minute (GPM) rate and acre foot total. If other units are required, they can be set in the field.</i>	Gallons Liters Barrels (42 gallons) Cubic Feet Cubic Meters Million Gallons ¹ Mega Liters ¹ Imperial Gallons Million Imperial Gallons ¹	Second Minute Hour Day	Gallons Cubic Meters x 1000 Cubic Feet Cubic Feet x 1000 Million Cubic Feet Imperial Gallons Imperial Gallons x 1000 Million Imperial Gallons Acre Inch Acre Foot Fluid Ounce
		Bidirectional		
		Forward Total, Reverse Total, Net Total, Batch Forward Total, Batch Reverse Total ²		
Power	One lithium 7.2V 'D' size battery pack, replaceable. DC Power available for 4-20mA output meters			
Scaled Pulse Output	Signal	Current sinking pulse, isolated, 36 Vdc at 10 mA max		
	Pulse Rates	User-scalable from 0.1 to 99,999.9 volume units/pulse. Pulse width varies with output frequency, 150 pulses/sec max		
Options	4-20Ma Current Loop	Isolated, passive, 24Vdc, 650 Ω maximum current loop (External DC powered units only)		
	Serial Communications	Isolated, asynchronous serial RS485, Modbus® RTU protocol		
	Sensus Smart Output	Connects to Sensus SmartPoint		
Cable	Optional Output Cable	20ft (6m) standard length polyurethane jacketed cable—for power and outputs. (Lengths up to 200' (60 m) available.)		
Conductivity	>20 microSiemens/cm			
Empty Pipe Detection	Hardware/software, conductivity-based			
Environmental	IP67			

Modbus is a registered trademark of Schneider Electric.

* Specifications subject to change. Please consult our website for the most current data (seametrics.com).

¹ Rate Time Unit is available in Day only.

² Forward & reverse flow totals are non-resettable. Batch forward total & batch reverse total can be reset.

Kynar is a registered trademark of Arkema, Inc.

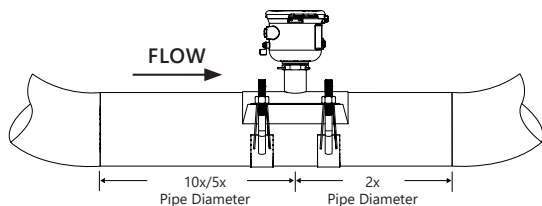

Upstream straight pipe is selected during initial setup. Upstream options are 5X or 10X the diameter and are based on the amount of straight pipe available in either new or propeller meter replacement installation. Downstream straight pipe requirement is 2X the diameter. See programming setup for details.

Dimensions

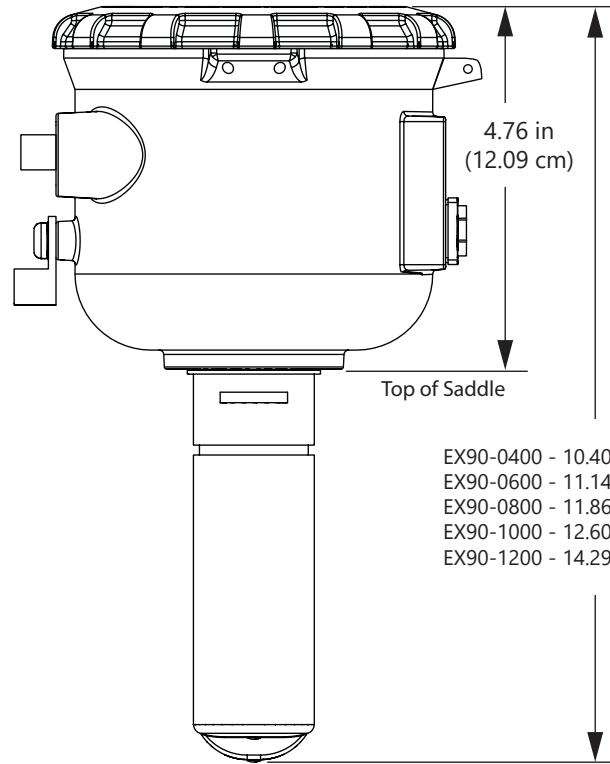
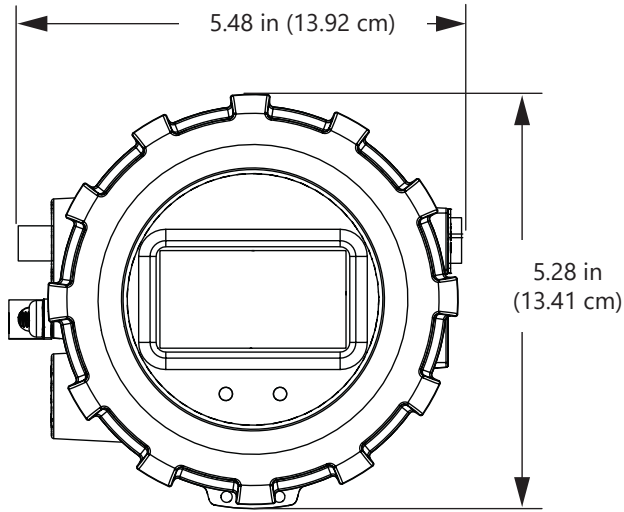

- EX90-0400 - 10.40 in (26.42 cm)
- EX90-0600 - 11.14 in (28.30 cm)
- EX90-0800 - 11.86 in (30.12 cm)
- EX90-1000 - 12.60 in (33.73 cm)
- EX90-1200 - 14.29 in (36.30 cm)

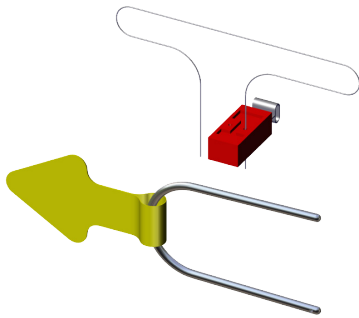

Install security clip and seal during installation if regulations require. Security seal wire threads through hole in security clip.



Install display security tab during installation if regulations require.



Install display security seal and captive screw security wire during installation if regulations require.

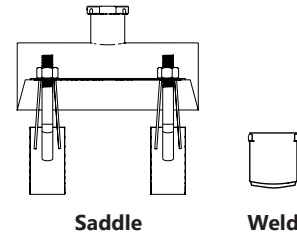

Saddle Size	Saddle Range	Carbon or 316 SS Weld Fitting
4"	4.00" - 4.90"	4"
6"	6.00" - 6.90"	6"
8"	8.00" - 9.05"	8"
10"	10.00" - 11.10"	10"
12"	12.10" - 13.20"	12"

Consult factory if your OD does not match.



CAUTION: Ensure that the U-clip is installed and **never remove the U-clip retainer when the pipe is under pressure.** Always remove pressure from the pipe before you attempt to remove the meter. Removal under pressure may result in damage or serious injury.

Fitting Installation

EX90-Series meters require special saddles or weldo-o-lets that ensure that the flow sensor is installed to the correct depth. The fitting must be installed in the pipeline before the meter can be installed. For best results, see straight pipe and full pipe information on pages 8 and 9.

If there is not enough straight run to smooth out the turbulence caused by valves, fittings, and changes in direction, some decrease in accuracy may result. This does not mean that the flow meter's reading is meaningless however. In some applications (control systems, valve operation, chemical addition) a repeatable reading may be more important than a highly accurate one.

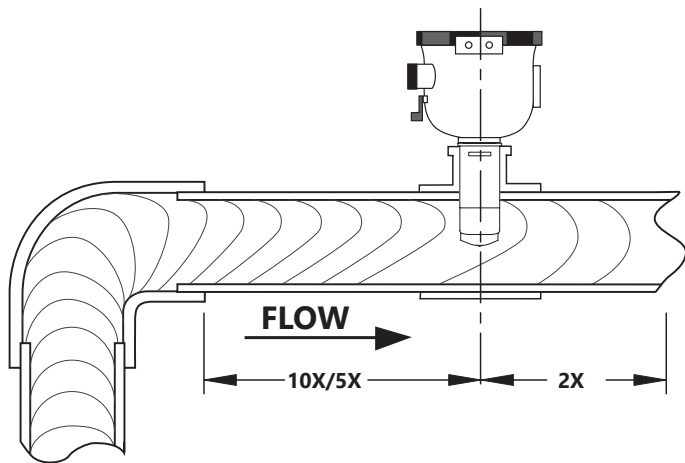

Upstream straight pipe is selected during initial setup. Upstream options are 5X or 10X the diameter and are based on the amount of straight pipe available in either new or propeller meter replacement installation. Downstream straight pipe requirement is 2X the diameter. See programming setup on page 14 for details.

Meter Installation

After the saddle or weld-o-let is installed in the pipeline, the meter can be installed in the fitting. After noting the direction of the flow arrow, press the meter into the fitting as far as it will go. Retain the meter in place by inserting the U-clip. The pin can be installed from either side. It may be necessary to rotate the probe back and forth slightly to start the pin into the slots on the probe. Slide the pin in as far as it will go.

Side (3 o'clock), top (12 o'clock) installations are acceptable.

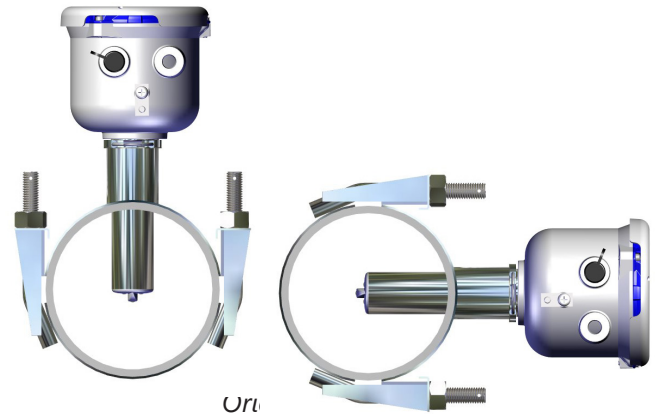

Chemical Injection

When any magmeter, by any manufacturer, is used in a chemical injection application (including fertigation), the chemical injection point must be placed downstream of the magmeter OR far enough upstream for complete mixing to occur before the fluid reaches the meter. When unmixed chemical or fertilizer alternates with water passing through the meter, the rapid changes in conductivity may cause sudden spikes and drops in the meter's reading, resulting in inaccurate measurement. The magmeter will restabilize, however, with a steady flow of fluid of uniform conductivity.



Caution: In chemical injection applications, install chemical injection point downstream of magmeter, or far enough upstream to allow complete mixing of fluids before the meter.

New Saddle Installation

BEFORE INSTALLING measure & record inside diameter (ID) of pipe.

1. Clean the mounting surface, remove any roughness from the area and cut a 1.75" hole into pipe. Place gasket centered over pipe opening.



2. Place saddle top over gasket.

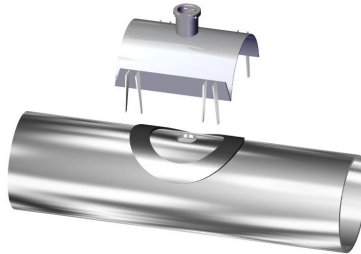

3. Make sure saddle top covers entire gasket.

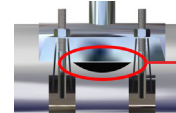

NOTE: Gasket will extend outside of a 4" pipe saddle's sides.

4. Place the saddle clamps under the pipe and align with the clamp guides on the saddle top.

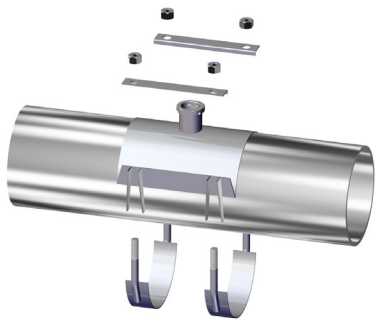

5. Place saddle plates over saddle clamp threads. Attach nuts and tighten as shown below. Torque to 75 ft-lb in cross pattern.

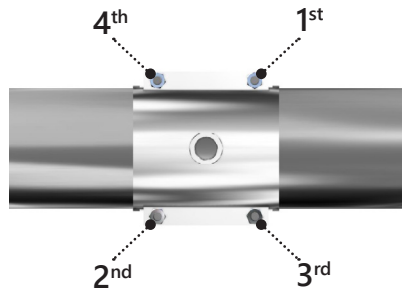

6. Insert the EX90 sensor into the saddle fitting and secure with mounting clip or attach security clip and seals if required.



Weld-o-let Installation

BEFORE INSTALLING measure & record inside diameter (ID) of pipe.

1. Clean the mounting surface, remove any roughness from the area and cut a 1.75" hole into pipe. Place gasket centered over pipe opening.



2. Install weld-o-let

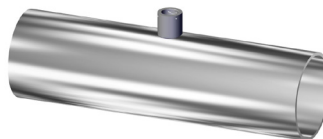

6. Insert the EX90 sensor into the weld-o-let fitting and secure with mounting clip or attach security clip and seals if required.

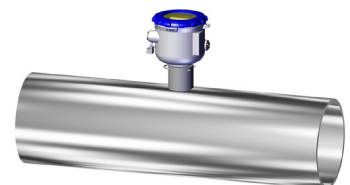

Grounding

For All Installations. Although not necessarily required in every circumstance, to aid with the reduction of electrical noise, static, and induced or transient voltages, every EX90 installation will benefit by connecting the ground lug of the meter to a 5/8" x 8' independent ground rod dedicated to the meter using at least a 10 GA ground wire.

Electronically Noisy Installations. When the EX90 is installed in an electrically noisy system, such as near a VFD etc. an independent ground rod is always recommended to help with the reduction of the electrical noise and to help protect against any large electrical spikes. In electrical noisy installations, always confirm the rest of the equipment is also well grounded. Do not connect VFD ground rods to any other equipment.

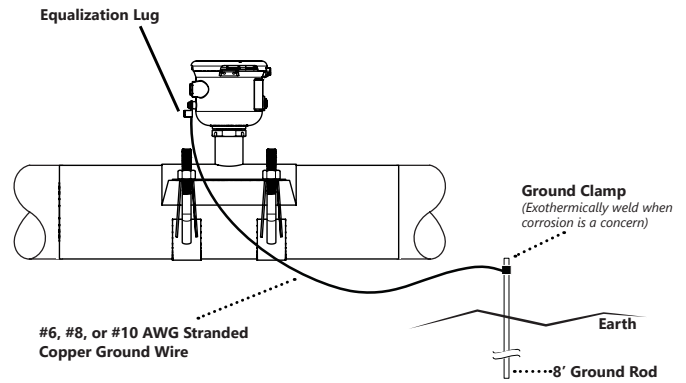

Straight Pipe Recommendations (X = diameter)

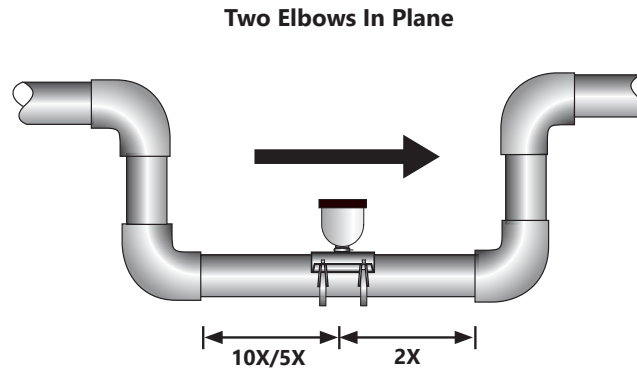

Pipe configuration selected during program setup.

Full Pipe Recommendations

Possible Problem

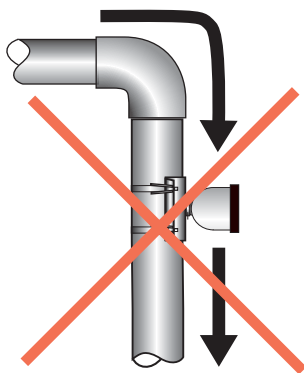

Can create air pocket at sensor

Better Installation

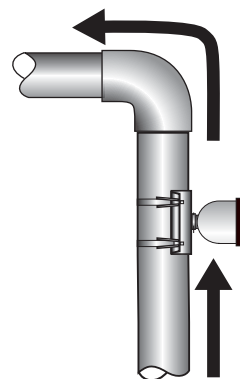

Allows air to bleed off

Full Pipe Recommendations

Possible Problem

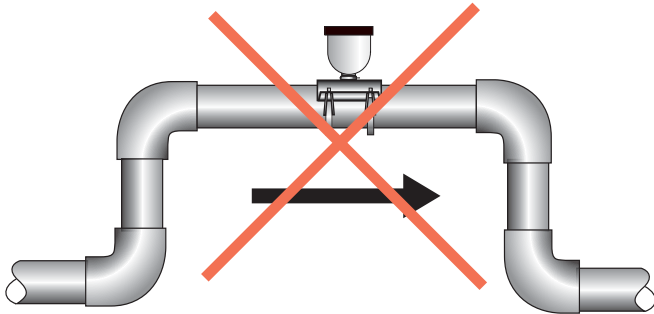

Allows air pockets to form at sensor

Better Installation

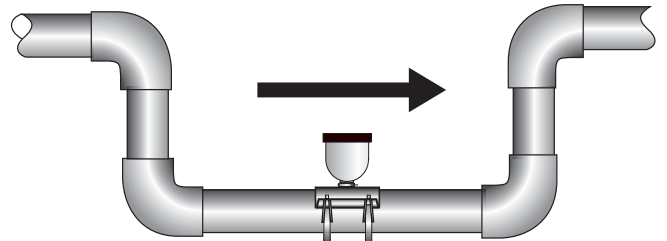

Ensures full pipe

Possible Problem

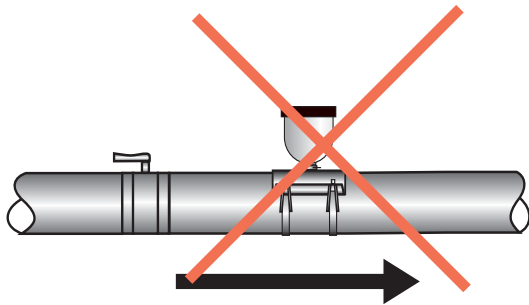

Post-valve cavitation can create air pocket

Better Installation

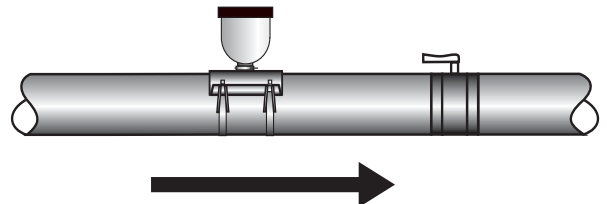

Keeps pipe full at sensor

Possible Problem

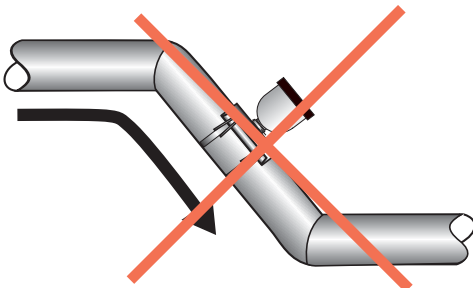

Air can be trapped

Better Installation

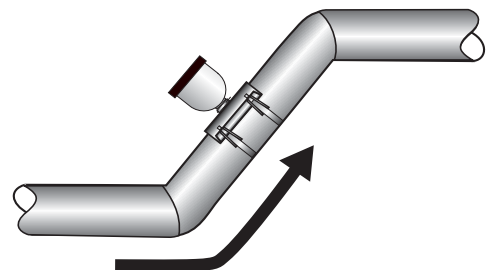

Allows air to bleed off

EX90 General Cable Information

The EX90 meter has two power/output cables that can be installed. The 4-pin cable contains the wires for DC power and pulse output. The 8-pin cable contains the wires for DC power and pulse, 4-20 mA or Modbus® output options when ordered. See diagrams below for details.

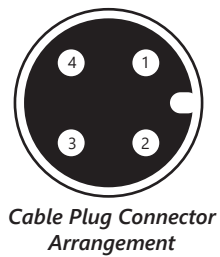

- *Red (P1) DC+
- *Black (P2) DC-
- Green (P3) Pulse +
- White (P4) Pulse -

Battery Power with Pulse Output

*Optional

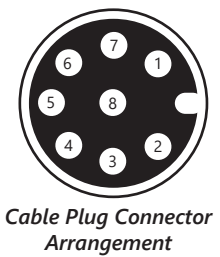
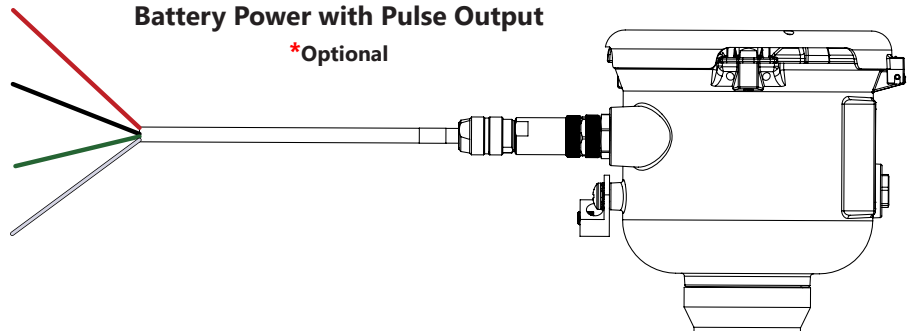

- *Red (P1) DC+
- *Black (P2) DC-
- Green (P3) Pulse +
- White (P4) Pulse -
- Gray (P5) Iso-GND
- Blue (P6) B(-)
- Orange (P7) A(+)
- Brown (P8) N/A

Modbus® Output

*Optional

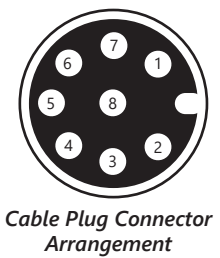
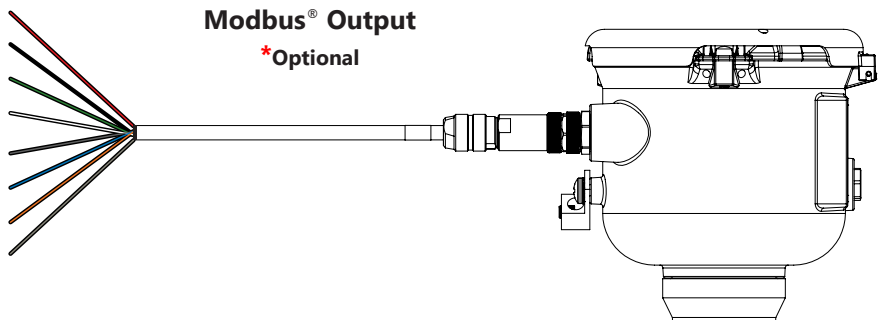

- Red (P1) DC+
- Black (P2) DC-
- Green (P3) Pulse +
- White (P4) Pulse -
- Gray (P5) N/A
- Blue (P6) 4-20mA-
- Orange (P7) 4-20mA+
- Brown (P8) N/A

**4-20mA Output
(DC Power Required)**

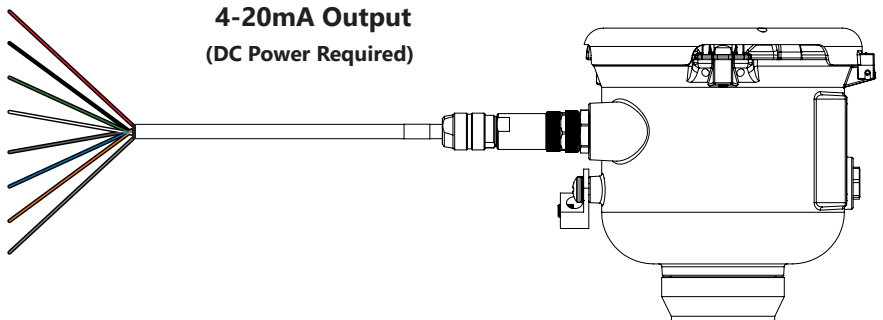

Option IDs

O ID	POWER SOURCE / OUTPUT(S)
BXX	= BATTERY POWER / PULSE SCALED
BXS	= BATTERY POWER / PULSE SCALED / MODBUS®
D1L/D2L	= DC POWER / PULSE SCALED AND 4-20mA

Cable Shield. In general, the cable shield and its bare drain wire should be left unconnected at the user equipment end of the cable to minimize "ground loop" problems.

Pulse Output Configuration. A pulse output is standard on all models. Since this is an isolated output, the external equipment must include a DC power source to regenerate the pulse from the open-collector output (transistor equivalent of a contact closure). A pull-up or pull-down resistor may be needed if not included in the user equipment. Both the power source and resistor may be supplied internally in some types of control and monitoring devices. If not, as for most PLC discrete input modules, they must be added externally at the module input terminals. The pulse output rate in volume units/pulse can be set by the user via the SETP tab on the meter's setup menus.

Because the pulse output of an EX90 meter is set by the user, care must be taken to assure the output pulses do not exceed the maximum frequency of the meter while also ensuring a reasonable resolution.

K-factor. Remember that SETP is expressed in units totaled per output pulse (G/P if using gallons) while K-factors are expressed in pulses per gallon (P/G.) To determine K-factor from SETP, divide 1 by SETP (if SETP is expressed in gallons.) Conversely, 1 divided by the K-factor equals SETP

EX90 battery powered units have a maximum output frequency of 150 Hz.

Because all pulse outputs (SETP) are configured in (rate) units totaled per pulse, all sizes of meters can be configured with the same SETP values

For example, if your rate is chosen as gallons per minute (GPM) the table below applies. If your rate is different, simply use your rate label in place of (GPM.) The numerical values will remain the same.

Lower frequency output pulses (1 pulse for some particular number of gallons) can also be set.

Any output frequency can be determined by:
 Rate (units/minute) ÷ SETP (units/pulse) = pulse/minute
 Hz = pulse/minute ÷ 60 seconds / minutes

SETP	Flow Rate at 1 Hz (GPM)	Flow Rate at 150 Hz (GPM) <i>Battery Powered Meters</i>
0.1	6	900
0.2	12	1800
0.3	18	2700
0.4	24	3600
0.5	30	4500
0.6	36	5400
0.7	42	6300
0.8	48	7200
0.9	54	8100
1.0	60	9000

Pulse Units. The units of measure of SETP are independently selectable and are not tied to rate or total. Upon change of the SETP unit, the pulse output may take up to 10 seconds, or the duration of one pulse (whichever is longer) to take effect.

If Pulse Output is Inconsistent. The DAMP filter may need to be increased.

Pulse Width Timing. The unit and value of SETP must be chosen to keep the duration between meter pulse outputs to less than 500 seconds.

Pulse Timing in Battery Powered Units. The output pulse width in battery powered units is short and varies with pulse frequency. (See table)

Output Pulse Width of Battery Powered Units		
Output Pulse Frequency	Output Pulse Width as a Percentage of the Pulse Period (Pulse period = 1000 milliseconds/frequency)	
Zero to 1 Hz	Multiply the pulse period by 0.01	= Output Pulse Width (ms)
>1 to 20 Hz	Multiply the pulse period by 0.05	= Output Pulse Width (ms)
>20 to 100 Hz	Multiply the pulse period by 0.1	= Output Pulse Width (ms)
>100 to 150 Hz	Multiply the pulse period by 0.15	= Output Pulse Width (ms)

Example: If frequency = 20 Hz then the pulse period = 50 milliseconds and pulse width = (.05 x 50 milliseconds) = 2.5 ms

Analog Output (4-20mA) Configuration.

(Not available on battery only units.)

Since the meter’s analog output is isolated and passive, loop power must be supplied externally as shown on next page. (In addition, an external resistor R_L will be needed to convert the loop current to voltage for voltage-only input devices.)

The meter’s loop transmitter minimum voltage drop is 6Vdc which, with wiring resistance and loop power supply voltage, will determine the maximum resistance for R_L.

The flow rates corresponding to 4 and 20mA can be set by the user via the SET 4 and SET20 tabs on the meter’s setup menus.

Note: As configured by the factory, any alarm state will force 22.8mA on the loop.

This can be changed to 3.2mA - see Technical Bulletin: ‘iMAG4700/AG3000: Changing the 4-20mA Alarm’

Modbus® Serial Communication Configuration

(factory configured)

These connections provide a half-duplex, isolated, RS485 serial communications port using the Modbus® messaging protocol. The TXD connection is the transmitted data output from the meter and RXD is the received data input to the meter. See Seametric’s Modbus® Interface Description, LT-103393 (available at www.seametrics.com) for supported Modbus® message protocol and electrical interface specifications.

A 120-ohm termination resistor is built into the Modbus® option board but is shipped in the unused position. To engage the termination resistor, move the jumper on JP1 from position 3-4 to position 1-2.

Pulse Output Application - Sourcing Mode (Recommended for $R_{in} < 30k\Omega$)

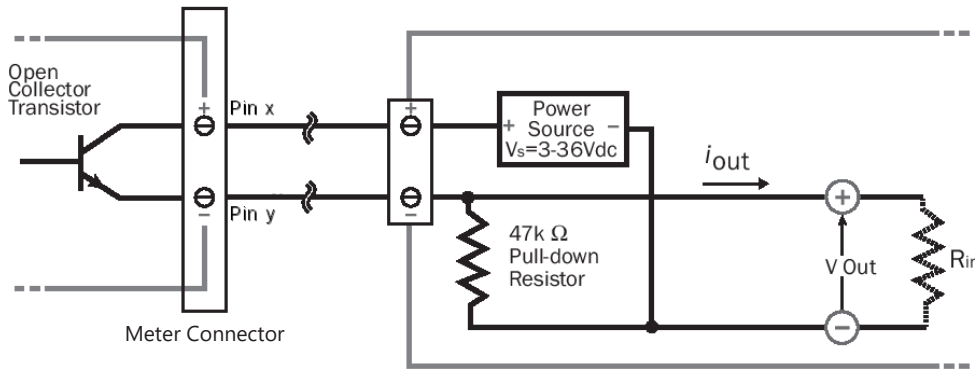

Current Sourcing Pulse Waveform

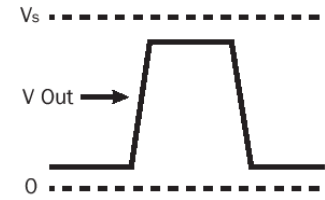

Pulse Output Application - Sinking Mode (Recommended for $R_{in} > 30k\Omega$)

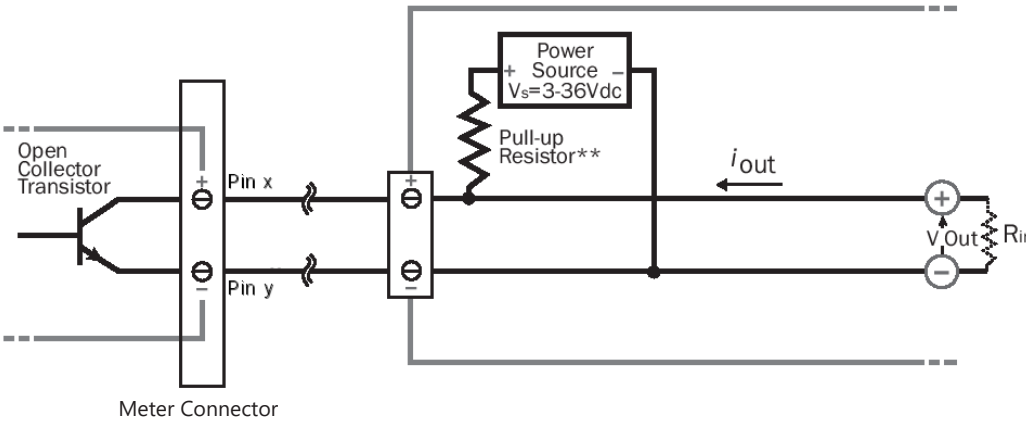

Current Sinking Pulse Waveform

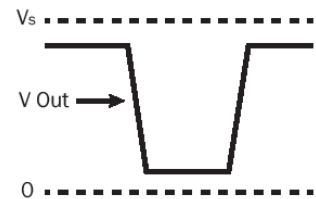

Analog (4-20mA Current Loop) Output Application

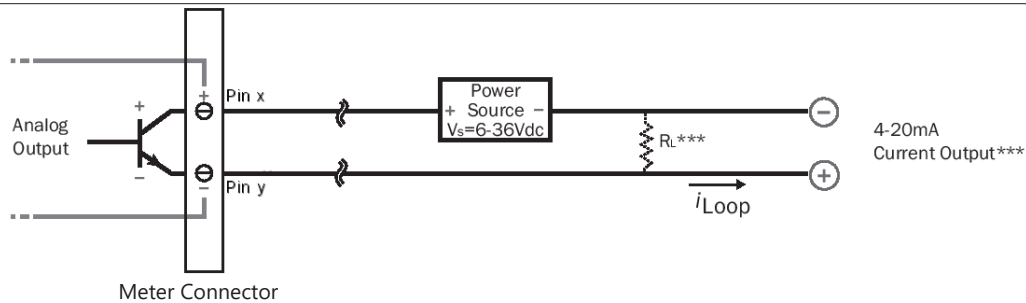

** Minimum resistor value is $(100 \times V_s)$ ohms. Higher resistances maybe used depending on frequency and cable length. Longer cables and high frequencies require lower resistance.

*** Resistor R_L converts 4-20mA current to voltage for voltage input only devices.

Minimum Flow

As with any other flow sensor, there is a rate below which the EX90-Series sensor cannot read. Check the table below for the minimum flow rate detectable by the sensor for a given pipe size.

Nominal Pipe Size	4"	6"	8"	10"	12"
Low Flow Cutoff GPM Low Flow Cutoff LPS	19.3 1.22	43.11 2.72	77.1 4.86	120.5 7.6	173.5 10.95
Min GPM Min LPS	64.3 4.1	144.6 9.1	257 16.2	401.6 25.3	578.3 36.5
Max GPM Max LPS	578 36.5	1301 82.1	2313 145.9	3614 228	5204 328.3

Standard Menu Options

T UNIT

View or change TOTAL volume units

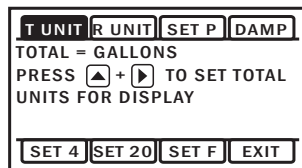

R UNIT

View or change flow RATE units

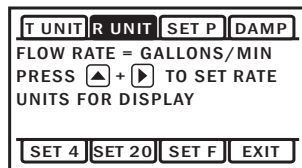

SET P

View or change pulse output scaling

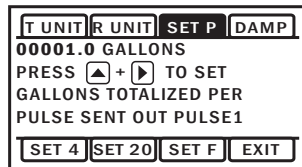

DAMP

View or change # of samples for rolling average.

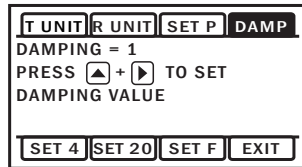

Filtering

The software of the EX90-Series filters out electrical noise and averages sudden variations in the flow to smooth the output. It takes a matter of seconds for the flow sensor to get up to full output after flow begins.

Electrode Coating

Grease or other adhering, non-conductive materials can stop flow detection if the electrodes become heavily coated. To clean the electrodes, remove the sensor from the pipe and gently wipe off the electrodes (three silver bumps) on the reading face of the flow sensor. A mild soap (dish washing liquid for example) can be used to aid the cleaning process.

SET 4

View or change flow rate corresponding to 4mA. (Externally powered units only)

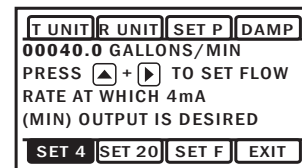

SET 20

View or change flow rate corresponding to 20mA. (Externally powered units only)

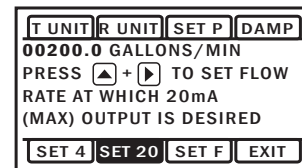

EXIT

Return to HOME SCREEN or enter SUBMENU

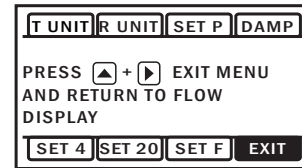

Special SUBMENU for Further Options

The EXIT tab in the MAIN MENU has a second function. If, instead of using the hold and tap sequence to return to the HOME screen, you tap seven times, you will be redirected to a SUBMENU screen from which you can access several more options.

Navigation in this SUBMENU is the same as for the MAIN MENU. Whenever you wish, go to the EXIT tab in the SUBMENU and perform the hold and tap sequence to return to the MAIN MENU.

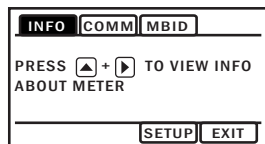

Sub-Menu

INFO: Meter model number, serial number, and firmware version.

COMM: Modbus® baud rate and parity.

MBID: Modbus® address

SAMP: Sample rate (Battery powered version only.)

EXIT: Return to MAIN MENU or enter next submenu.

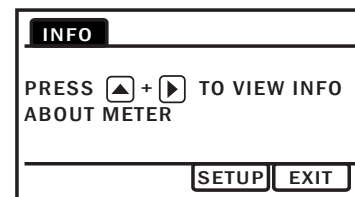

Sub-Menu - Battery Only Version

Initial Setup



INITIAL SETUP OF ID, HOLE, AND PIPE IS REQUIRED FOR THE METER TO OPERATE PROPERLY.

When you remove the meter from the box, it will prompt you to perform initial SETUP of ID, Hole and PIPE before you can proceed to other menu functions or return to the HOME screen.

SETUP Menu Functionality

The SETUP menu works slightly different than other menus inside the EX90. The black square highlighting the left most text is similar to a cursor on a computer. It lets you know where you are within the menu. Press Up 1x and the menu category will change. The categories are as follows:

ID (Internal Diameter in inches)

HOLE (Hole Size Cut into Pipe for Inserting Meter)

PIPE (Piping Configuration Selection)

ID

The Internal Diameter (or I.D.) of the Pipe in which the EX90 is installed is critical to the meter's performance. The EX90 senses a local velocity around the electrodes and uses that information to extrapolate the flow over the entire pipe section. The ID is also used 'under the hood' to scale many critical values such as Low Flow Cutoff, Max Flow Rate, etc. The installer should measure the ID in the most accurate way possible prior to saddle installation.

HOLE

You must change setting from the default N/A to one of the following:

SMALL

New Installations will cut a 1.75" hole into the pipe. This is considered a "SMALL" hole. In this type of installation, the meter is flush to the diameter of the hole. This represents an ideal installation condition, because the cross-sectional area at the measurement point is equal to the I.D. of the pipe.

LARGE

Retrofit installations already have a hole cut into the pipe. Typically they are quite large (especially when replacing mechanical meters), although the exact size depends on the pipe size. These are considered "LARGE" holes. In this

type of installation, the meter has significant room between it and the hole cut into the pipe. When water flows by the meter, it fills this extra cross sectional area while flowing past the measurement point. This means that unlike the "SMALL" hole case, the cross sectional area at the point of measurement is not equal to the I.D. of the pipe. When this menu is selected, the EX90 will compensate for this condition.

PIPE

The PIPE menu is used to compensate for altered velocity profiles in various piping configurations. When obstructions or disturbances are introduced to straight pipe (particularly upstream of the meter), the velocity profile changes shape. Since the EX90 measures a relatively small cross section of the velocity profile, large distortions of this profile can lead directly to measurement error. The pipe menu has distinct pipe configuration compensation built into the EX90 allowing you to select the closest condition to your actual pipe and allows the EX90 to operate at peak performance.

You must change setting from the default N/A to one of the following:

STRAIGHT

Straight Pipe is a relative term. For this configuration, the EX90 considers the pipe to be straight if there are 15+ diameters of straight pipe upstream from the meter and at least 2 diameters downstream from the meter from any obstruction in the pipe.

10/2 ELB

This selection represents an install condition in which there exists a single in plane elbow 10 diameters upstream from the meter and 2 diameters downstream from the meter.

5/2 ELB

This selection represents an install condition in which there exists a single in plane elbow 5 diameters upstream from the meter and 2 diameters downstream from the meter.

ADJ

The adjustment menu is for installers and regulating bodies. This menu allows manual adjustment of the rate (on a % of reading basis) in installations outside of the scope of this document. This menu should be used when a known reference is temporarily (or otherwise) installed into the system and adjustment can be made with high confidence and reliability.

Changing Flow Meter Settings

Home Screen and General Navigation

The HOME Screen displays flow volume, direction of the flow total and flow RATE along with status conditions such as Empty Pipe. Two buttons below the LCD display are used to access menu screens for viewing and changing meter setup parameters.

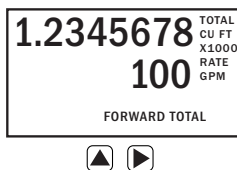

These two buttons are light sensors which can detect when a finger is covering them and operate upon release. Only three button touch actions are needed to control navigation through the menus, settings changes and back to the home screen.

HORIZONTAL SCROLLING:

Tap right button to scroll horizontally through menu tabs or move horizontally within a tab dialog when applicable.



VERTICAL SCROLLING:

Tap left button to change a highlighted item within a tab dialog.



SELECT/ENTER/EXIT:

Hold left button while tapping right button once to enter or exit a tab dialog or to navigate between the HOME and other menu screens.



Changing Total Direction/Resetting Batch Totalizers

On the Main screen, hold [right arrow] and tap [up arrow] 7 times to scroll through the total direction options. Release [right arrow] to select a total direction.

Once BATCH FORWARD or BATCH REVERSE is selected, tap [right arrow] four times to reset batch totalizer.

To Enter the Menu System perform the hold and tap sequence. The Passcode entry screen will display. The default passcode is 000000. If a different passcode has previously been set, use the [up arrow] and [right arrow] to enter that passcode. In either case, hold and tap again to move into the menu system. (If you enter the wrong passcode, hold and tap again to return to the previous screen. See page 16 for information on how to change a passcode.)

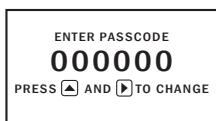

Making Selections

Once in the Menu System, move from tab to tab by tapping the right button. (See the next page for details on the various available tabs.)



Select the Parameter. In the screen for the highlighted tab you will see the current parameter value for that tab. Tapping the right button, move to the tab for the parameter you want to change.



In this example, the first line indicates that the current unit for the TOTAL is GALLONS. The next two lines tell you what to do next.

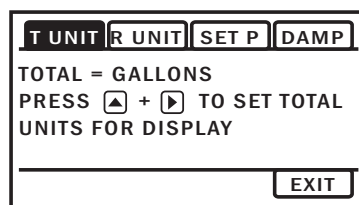

If you would like to change the TOTAL units, just perform the hold and tap sequence to bring up a screen to change the setting.

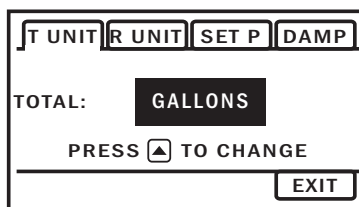

Scroll Through Setting. Select the new setting by scrolling through a list of selections by tapping the left button to find a different TOTAL unit.



Accept Changes. To accept any changes you have made, perform the hold and tap sequence.



When Finished Making Changes. When you are finished making changes, move to the EXIT tab using the right button.



To return to the HOME screen, perform the hold and tap sequence.



Programming Passcode and Tamper Prevention

To prevent tampering or changes to the program, *after initial set-up*, either enter a security pass-code, or remove the display lid and place a security tab over one of the arrows before installing the housing security seal.

Placing a security tab over either display button will prevent additional changes to the program, while allowing someone to wake the display from sleep mode. Placement over the right button will also allow scrolling through the flow direction feature. Placement over the left button will prevent changes to the flow direction. In either position, non-resettable totals will not be affected.

The EX90 has a passcode system for restricting access to the menus. The EX90 comes from the factory with the passcode set to 000000. When a user attempts to enter the menu system (see details on page 14), the passcode entry screen will be displayed.

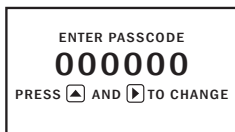

The default passcode is 000000. If a different passcode has previously been set, then the user must enter that passcode at this time. After entering the passcode, or leaving it at 000000 if using the default passcode, the user does the hold and tap sequence to move into the menu system.

To change the passcode, you must use the THIRD MENU screen. Access the THIRD MENU screen as follows:

- Enter the main menu system, as described above.

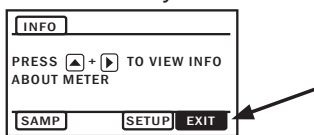

On the main menu, tab over to the EXIT tab and tap the up arrow five times. A SUBMENU screen will display.

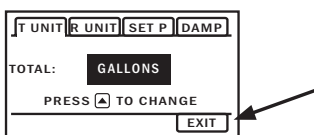

- On the SUBMENU screen tab over to the EXIT tab and tap the up arrow five times. The THIRD MENU screen will display.

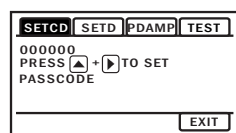

- To set the code, hold and tap SETCD and then use the [up arrow] and [right arrow] to enter the new code.

- Hold and tap again to return to the THIRD MENU screen.
- Tab to EXIT, and then hold and tap to return to the SUBMENU.

To change the number of decimal places in the total

- To set the decimal point, hold and tap on SETD and then use the [right arrow] to move the decimal point.
- Hold and tap again to return to the THIRD MENU screen.
- Tab to EXIT, and then hold and tap to return to the SUBMENU.

Power Indicators

A power indicator is displayed in the lower left of the main display window.

Any meter powered from an external power source will display a power plug icon when running on external power. If the connection to external power is lost, the meter will switch to the backup battery and the power icon will switch to a battery symbol.

OK on the battery indicator means battery voltage is above 6.4 volts.

LO on the battery indicator means the battery is low and should be replaced soon.



Being powered by external DC or AC



Being powered by battery - voltage is sufficient



Being powered by battery - voltage is low

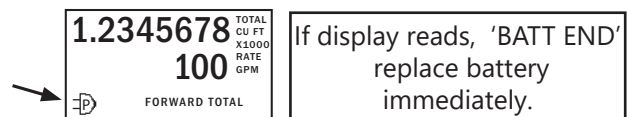

PDAMP

PDAMP is used to view or change the number of samples for rolling average of pulse output.

TEST

TEST allows the user to initiate a fully functional, artificial flow rate for the purpose of testing other connected equipment. When TEST is applied, all features of the meter will function at the stated flow rate (in gallons per second).

For TEST to function, the meter must be filled (not EMPTY PIPE).

To enter a value into the TEST feature, navigate to the TEST tab and enter a flow rate value in the VAL screen (in gallons per second only,) then **▶** to the VAL box and **▲** to the ON screen. This will initiate the TEST feature. The next **▲** would bring you to the OFF screen, but you can 'hold and tap' the arrows to return you to the sub menu while the feature operates.

After use, the TEST feature must be turned OFF. If the TEST feature is not turned OFF, the stated static flow rate (in gallons per second) will be shown any time the meter is full or in a flowing condition. Flow values recorded by the meter while the TEST feature is operating are permanently recorded in the displayed TOTAL. It may be useful to note that these values are only written to permanent memory every 15 minutes and cycling all power within this 15 minute time frame will return the meter to its previous total.

Battery Powered Units

To 'wake up' a battery powered meter, you may need to hold the up arrow for 5 seconds and release.

The EX90 meter comes configured with a 7.2V 'D' size lithium battery pack. In this configuration, the only option/output is the scaled pulse output which comes standard. Be sure to set your SETP value such that the meter will function properly over the flow range in your application (see page 11 for details). The sample rate of the meter is user selectable through the SAMP tab in the meter's sub-menu. Sample periods of 1/5, 1/3, 1, 3, 5, 15, 30, and 60 seconds can be selected. (A sample period of 15 seconds - 5.5 year battery life - is the default.)

Larger sample periods will yield longer battery life but slower response time. Care must be taken to select a sample period that is suitable for your application. See the table below for the expected battery life as a function of sample period.

DAMP/Filtering

The DAMP Filter allows multiple readings to be averaged over time, thus reducing the meters sensitivity to minor changes in flow rate. The DAMP Filter is extremely useful for situations where the flow is not perfectly steady (pulsating flows, turbulent flows, etc.)

The DAMP Filter works differently depending on the SAMP selection:

SAMP < 1 second

When the SAMP setting is less than 1 second, the DAMP filter is defined on a "per second" basis. The DAMP filter always utilizes at least 1 second of data for its filter. Then, it adds however many seconds you've selected in the DAMP menu setting to that 1 second of data. For instance, if you set the DAMP menu to 7, your EX90 meter will utilize 7+1=8 seconds of data within the filter. This means that the filter will average readings for 8 seconds prior to displaying a reading. After the first reading is displayed, the filter kicks out the oldest 1 second of data, adds the newest 1 second of data, recomputes the average flow rate, and displays it to the screen/output. In this way, it is considered a "running average".

SAMP > 1 second

When the SAMP menu is set to a number greater than 1 second, the DAMP menu is defined on a "per reading" basis. Again, the DAMP filter must always use at least 1 reading to generate a flow rate, so the filter will add 1 to your selection. For instance, if SAMP is set to 15, and DAMP is set to 7, the DAMP filter will utilize 7+1=8 readings worth of data for the filter. This means that the filter will average 8 readings for the display.

Battery Life/Sample Period

Sensor sample period(s) (Seconds)	Expected battery life*
1/5 (0.2)	4.5 Months
1/3 (0.33)	7 Months
1	1.5 years
3	3.25 years
5	4 years
15	5.5 years
30	6 years
60	6.25 years

**Based on 85% battery capacity at room temperature.*

Troubleshooting

Problem	Probable Causes	Things to try...
Blank Display	Battery has not been plugged in Dead battery	Plug in the battery Replace battery
Flow rate reading fluctuates excessively when flow is unchanging	Excessively turbulent or unsteady flow due to partially closed valves or other flow obstructions Pipe not full Pulsing flow due to combining multiple upstream flow sources Insufficient mixing of upstream chemicals Low fluid conductivity < 20 $\mu\text{S}/\text{cm}$ Noisy electrical environment <ul style="list-style-type: none"> • Shared grounds • Too close to VFD • Faulty or poor power supply • Cable length • Shared conduit • Unshielded cable 	Eliminate or minimize causes of flow disturbances or increase meter damping Provide back pressure or other means to ensure pipe is filled Move connection point further upstream Move chemical injection downstream from meter Replace with different type of meter Improve grounding at meter and nearby potentially noisy electrical equipment. Increase distance between meter and electrical noise sources. Try power reset
Flow Rate appears correct but pulse/ frequency output is low, erratic or absent	External device input impedance too low Cable too long	Use sourcing rather than sinking interface connection Reduce interface pull-up resistance
Flow Rate appears correct but pulse/frequency output is erratic and/or too high	Electrical noise sources interfering with pulse frequency signal Wrong type of cable Grounding problem	Isolate, remove or reduce noise sources. Move meter control cable away from noise sources. Use only twisted pair cable and ensure both signal wires are on same twisted pair Improve or try different grounding method
Flow rate steadily reads zero when there is flow	Pipe ID not set Flow is below cutoff (very low) Air in the pipe	Program ID of pipe Reading will resume when flow increases Reposition meter for full pipe
Flow rate intermittently drops when there is flow	Air in the pipe	Reposition meter for full pipe
Jumpy reading	Improperly grounded Pulsing flow	Check for proper grounding Increase DAMP value Use external power source (allows more flow averaging) Try power reset

Error Messages

Under certain conditions an error message may be displayed.

Message	Description	Notes
INIT	Initialization is occurring during power up.	
EMPTY PIPE	Fluid is not detected between the sensing electrodes.	
LO in battery icon	Battery is getting low, replace soon. Meter still functions.	Above 6.4V, OK appears in icon
BATT END	Battery is very low (approx. 6.1V). Totalizer stops updating.	
COIL FAIL	Coil current too high or too low (short or open).	
COMM FAIL	Communication between transmitter and sensor board fails.	
OVER RANGE	Rate exceeds number of digits that can be displayed. Adjust units.	
SET ID	Pipe ID has not been set.	
SET HOLE	Installation hole type (small, large) has not been set.	
SET PIPE	Pipe setting has not been selected.	
INIT FAIL	Initialization has failed. Ribbon cable plugged in AFTER power, or there is no communication between transmitter & sensor board.	Try power reset

SEAMETRICS LIMITED WARRANTY

The limited warranty set forth below is given by Seametrics, with respect to Seametrics brand products purchased in the United States of America.

Seametrics warrants that products manufactured by Seametrics, when delivered to you in new condition in their original containers and properly installed, shall be free from defects in material and workmanship. **Seametrics products are warranted against defects for a minimum period of two (2) years from date of installation, unless otherwise specified, with proof of install date. If no proof of install date can be provided, warranty period will be two (2) years from date of shipment from Seametrics, as defined on Seametrics' invoice.** Seametrics' obligation under this warranty shall be limited to replacing or repairing the part or parts, or, at Seametrics' option, the products, which prove defective in material or workmanship. The following are the terms of Seametrics' limited warranty:

- a. Buyer must give Seametrics prompt notice of any defect or failure and satisfactory proof thereof.
- b. Any defective part or parts must be returned to Seametrics' factory or to an authorized service center for inspection.
- c. Buyer will prepay all freight charges to return any products to Seametrics' factory, or another repair facility, as designated by Seametrics.
- d. Defective products, or parts thereof, which are returned to Seametrics and proved to be defective upon inspection, will be repaired to factory specifications.
- e. Seametrics will deliver repaired products or replacements for defective products to the buyer (ground freight prepaid) to the destination provided in the original order.
- f. Products returned to Seametrics for which Seametrics provides replacement under this warranty shall become the property of Seametrics.
- g. This limited warranty covers all defects encountered in normal use of Seametrics products, and does not apply to the following cases:
 - i. Loss of or damage to Seametrics product due to abuse, mishandling, or improper packaging by buyer
 - ii. Failure to follow operating, maintenance, or environmental instructions prescribed in Seametrics' instruction manual
 - iii. Products not used for their intended purpose
 - iv. Alterations to the product, purposeful or accidental
 - v. Electrical current fluctuations
 - vi. Corrosion due to aggressive materials not approved for your specific product
 - vii. Mishandling, or misapplication of Seametrics products
 - viii. Products or parts that are typically consumed during normal operation
 - ix. Use of parts or supplies (other than those sold by Seametrics) which cause damage to the products, or cause abnormally frequent service calls or service problems
- h. A new warranty period will be established for repaired products, or products replaced during the original warranty period.
- i. In the event that equipment is altered or repaired by the buyer without prior written approval by Seametrics, all warranties are void. Damage caused by equipment or accessories not manufactured by Seametrics may void the product's warranty.
- j. SOFTWARE: The Seller grants the user a non-exclusive license to use Seametrics' software, according to the following limitations and conditions:
 - i. The user may install the software on one or more desktop or laptop computers.
 - ii. All title and intellectual rights to the software are owned by Seametrics.
 - iii. No copies may be made or distributed except as described above.
 - iv. The user may not modify or reverse-engineer the software.

THE FOREGOING WARRANTY IS IN LIEU OF ALL OTHER WARRANTIES, WHETHER ORAL, WRITTEN, EXPRESSED, IMPLIED OR STATUTORY. NO IMPLIED WARRANTY, INCLUDING ANY IMPLIED WARRANTY OF MERCHANTABILITY OR FITNESS FOR A PARTICULAR PURPOSE, APPLIED TO THE PRODUCTS AFTER THE APPLICABLE PERIOD OF THE EXPRESS LIMITED WARRANTY STATED ABOVE, AND NO OTHER EXPRESS WARRANTY OR GUARANTY, EXCEPT AS MENTIONED ABOVE, GIVEN BY ANY PERSON OR ENTITY WITH RESPECT TO THE PRODUCTS, SHALL BIND SEAMETRICS. SEAMETRICS SHALL NOT BE LIABLE FOR LOSS OF REVENUES, OR PROFITS, OR INCONVENIENCES, EXPENSE FOR SUBSTITUTE EQUIPMENT OR SERVICE, STORAGE CHARGES, LOSS OF DATA, OR ANY OTHER SPECIAL, INCIDENTAL, OR CONSEQUENTIAL DAMAGE CAUSED BY THE USE OR MISUSE OF, OR INABILITY TO USE THE PRODUCTS, REGARDLESS OF THE LEGAL THEORY ON WHICH THE CLAIM IS BASED, AND EVEN IF SEAMETRICS HAS BEEN ADVISED OF THE POSSIBILITY OF SUCH DAMAGES. IN NO EVENT SHALL RECOVERY OF ANY KIND AGAINST SEAMETRICS BE GREATER IN AMOUNT THAN THE PURCHASE PRICE OF THE PRODUCT SOLD BY SEAMETRICS AND CAUSING THE ALLEGED DAMAGE. WITHOUT LIMITING THE FOREGOING, YOU ASSUME ALL RISK OF LIABILITY FOR LOSS, DAMAGE, OR INJURY TO YOU AND YOUR PROPERTY AND TO OTHERS AND THEIR PROPERTY ARISING OUT OF USE OR MISUSE OF, OR INABILITY TO USE THE PRODUCTS NOT CAUSED DIRECTLY BY THE NEGLIGENCE OF SEAMETRICS.

SOME STATES DO NOT ALLOW LIMITATIONS ON THE DURATION OF AN IMPLIED WARRANTY, SO THE ABOVE LIMITATIONS MAY NOT APPLY TO YOU. SIMILARLY, SOME STATES DO NOT ALLOW THE EXCLUSION OR LIMITATIONS OF CONSEQUENTIAL DAMAGE, SO THE ABOVE LIMITATION OR EXCLUSION MAY NOT APPLY TO YOU. THIS LIMITED WARRANTY GIVES YOU SPECIFIC LEGAL RIGHTS; HOWEVER, YOU MAY ALSO HAVE OTHER RIGHTS WHICH MAY VARY FROM STATE TO STATE.