



# Peristaltic pump 12 VDC Advanced

## Manual



*Meet the difference*

# Contents

About these instructions for use .....	3
1. Description .....	3
1.1 Operating principle .....	3
2. Preparing for use .....	3
2.1 Placement/replacement of the lithium-ion battery .....	4
2.1.1 Battery plate removal .....	4
2.1.2 Disconnecting the power cables and connecting the battery .....	4
2.1.3 Fitting battery and mounting battery plate .....	5
2.2 Charging the lithium-ion battery .....	5
3. Operation .....	6
3.1 Switching on .....	7
3.2 Direction of rotation .....	7
3.3 Revolutions per minute RPM .....	7
3.4 Use of tube .....	7
3.4.1 Type of tube .....	7
3.4.2 Inserting the pump tube .....	7
3.5 Additional features of the peristaltic pump .....	8
3.5.1 External pump connection .....	8
3.5.2 Start/stop system .....	8
4. Troubleshooting and maintenance .....	8
4.1 Troubleshooting .....	8
4.2 Maintenance .....	9
5. List of materials and consumables .....	10
6. Technical specifications .....	11
7. Environment and waste disposal .....	12
7.1 Correct disposal of the product .....	12
7.2 Correct removal of the battery .....	12
Appendix 1: Fitting and removing the carrying strap .....	13
Appendix 2: Operation membrane keys .....	13
CE Declaration of Conformity .....	15

Nothing from this document may be copied and/or made public by means of printing, photocopy, microfilm or in any other way whatsoever without the prior written permission of the publisher. Technical data can change without prior notification.

Eijkelkamp Soil & Water is not responsible/liable for damage/personal injury due to the use or misuse of this product.

Eijkelkamp Soil & Water is pleased to receive your feedback and comments about its products and this user manual.

## About these instructions for use



**When text follows a marker (as shown left), it means that an important instruction will follow.**



**When text follows a marker (as shown left), it means that an important warning will follow, drawing attention to the risk of injury to the user or damage to the unit. Please note: the user is responsible for ensuring his own protection at all times.**

*Text*

**Text in italics means that the actual text is shown on the display screen.**

## 1. Description

The peristaltic pump is a self-priming water pump. This battery-operated pump is primarily intended for taking groundwater samples. The pump can be operated at an adjustable speed, allowing water sampling at very low flow rates, but also at higher flow rates of up to approximately two litres per minute.

A maintenance-free 12 volt lithium-ion battery allows the pump to be operated for at least two to five hours at a time (depending on the load). The splash-proof housing (IP66) allows the pump to be used safely and trouble-free outdoors. The pump includes a detachable carrying strap.

### 1.1 Operating principle

A peristaltic pump operates on the basis of a suction force generated by compressing the flexible pump tube in the pump housing. Even when the pump is not running, at least one roller fully compresses the tube, which prevents water from flowing back, provided the pump is in good condition and the correct tube is used.

In theory, a suction pump cannot generate more suction force than the prevailing air pressure. This is about 1 bar, which corresponds to a pressure of about 10 m water column.

This means that to pump up water the distance from the pump to the groundwater level (regardless of the depth of the monitoring well) cannot exceed 10 m. In reality, however, pressure losses must also be taken into account, as a result of which this maximum depth of 10 m is not achieved. An important cause of pressure losses is the friction inside the tube. Depending on the diameter, length, and type of tube and the condition of the pump, the actual maximum ground water depth that can be reached is approximately 7 to 9 m. This is why peristaltic pumps are not used for greater depths.

## 2. Preparing for use

The peristaltic pump that leaves our factory is subjected to a rigorous final inspection. Upon receipt, first check that the pump and charger have not suffered any damage during transport. Loose parts, heard inside the housing of the pump or charger, indicate damage. You can check this by tilting the devices; do not open them yourself. In case of damage, please contact the supplier. Do not open the housing yourself.



**Do not operate the pump until you have read and understood this manual.  
Keep the manual in a place accessible to all users.**



**The peristaltic pump may not be used in hazardous areas.**



**Charge the battery before first use (see 2.2)!**

## 2.1 Placement/replacement of the lithium-ion battery

 **Only carry out this work indoors, in a clean, well-lit area.**

 **Prevent dirt from getting on the seal and battery plate.**

### 2.1.1 Battery plate removal

 **Use one of the supplied 3 mm hex keys.**

1. Carefully place the pump with the pumphead face down on a soft surface.
2. Remove the metal battery plate from the bottom of the pump by unscrewing the six screws in the anticlockwise direction using the supplied hex key (3 mm) and carefully removing the plate from the housing.

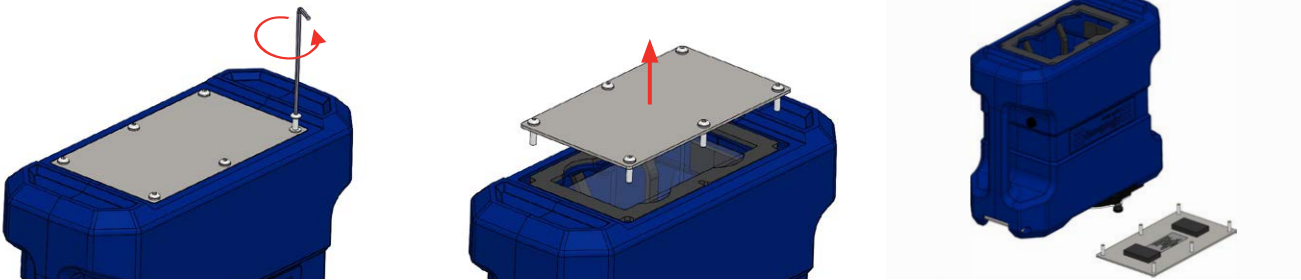

### 2.1.2 Disconnecting the power cables and connecting the battery

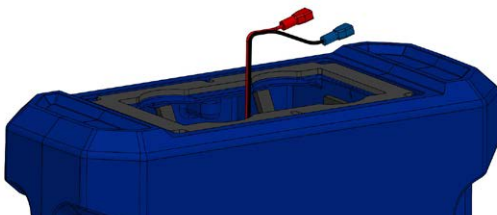

 **Only use a lithium-ion battery prescribed by Eijkelkamp Soil & Water (see section 2.2 and the sticker on the battery plate).**

Remove the power cables from the battery compartment and press the sliding plugs fully onto the battery terminals; red is plus and blue/black is minus.

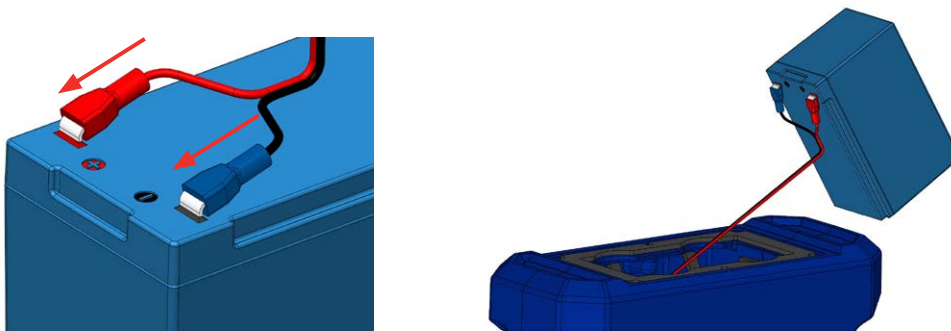

### 2.1.3 Fitting battery and mounting battery plate

1. Place the power cable in position, between the foam pads, so it does not get stuck.
2. Carefully slide the battery pack into the battery compartment in an upright position. The battery will be clamped slightly between the foam pads.

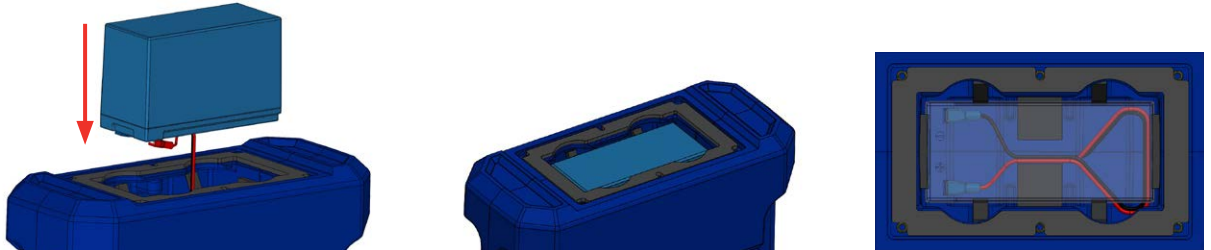

**Check that the seal and battery plate are clean. If necessary, gently blow clean or wipe with a neutral, non-greasy cleaner.**

3. Place the battery plate.
2. Replace the socket head screws and tighten evenly, step by step, crosswise in the clockwise direction (tighten firmly).

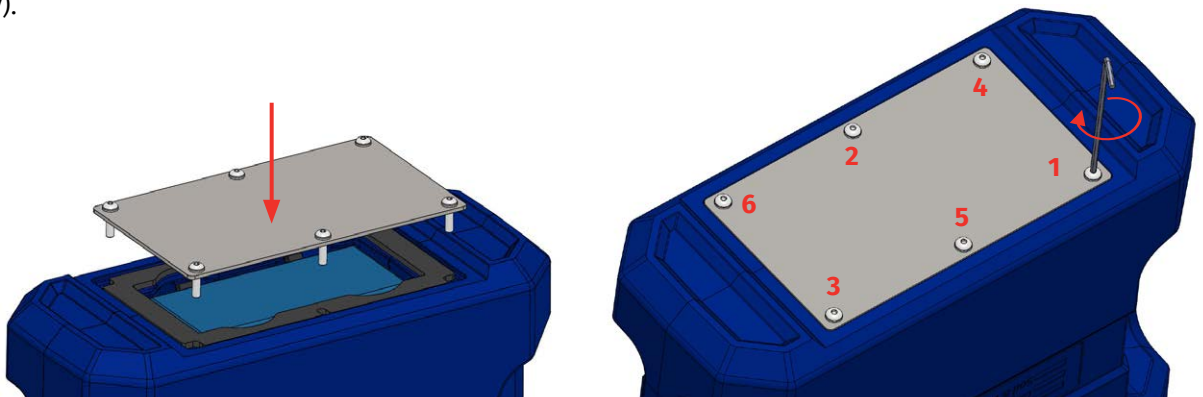

## 2.2 Charging the lithium-ion battery



**To charge the prescribed lithium-ion battery, use only the corresponding charger (item no. 123501). Other chargers, such as those from previous versions of the peristaltic pump and/or car battery chargers, may damage the device.**



**Do not charge the lithium-ion battery at an ambient temperature below 0 °C or above 40 °C.**



**This pump is only designed for use with a lithium-ion battery. Only use a new, undamaged battery.**

Battery prescribed by Eijkelkamp Soil & Water:



**Lithium-ion: LiFePO<sub>4</sub>**  
**Capacity/Voltage: 10 Ah/12.8 V (item no. Eijkelkamp 123503)**  
**Dimensions: approx. 151x65x95 mm (LxWxH)**

Depending on the country of delivery and/or the customer's preference, the peristaltic pump can be delivered with or without battery.

The following apply to use of the battery:

- The battery can be recharged at any time, without first being fully discharged.
- The charger can remain connected even when the battery is fully charged.
- To ensure the service life of the battery, it is protected against over-discharge.
- The pump may be used during charging. When the charger is connected, the pump is powered from the charger rather than the battery.
- When the battery is completely discharged, recharging takes up to six hours.

During charging, the battery indicator (figure 1 position 5) flashes slowly and shows the charge level with the colours red <30%, orange <70%, and green >70%.

If the peristaltic pump is not used for a longer period of time, it is advisable to store it with a charge level of approximately 50%. The battery charge rate is briefly shown on the display after the pump has been switched off. Recharge the pump every six months. If this is not done, the battery voltage may become too low, which will significantly shorten the battery life.

The battery can also be charged via a 12 V dashboard connection in the car. This requires a cable with a special plug. This cable (item no. 123505) is not supplied with the pump as standard.

### 3. Operation

The peristaltic pump is operated with the keys on the front panel (see figure 1). The keypad is carefully laid out and the keys are labelled with logical symbols. The control keys are membrane keys that provide tactile feedback. Just a light press is required to make contact.

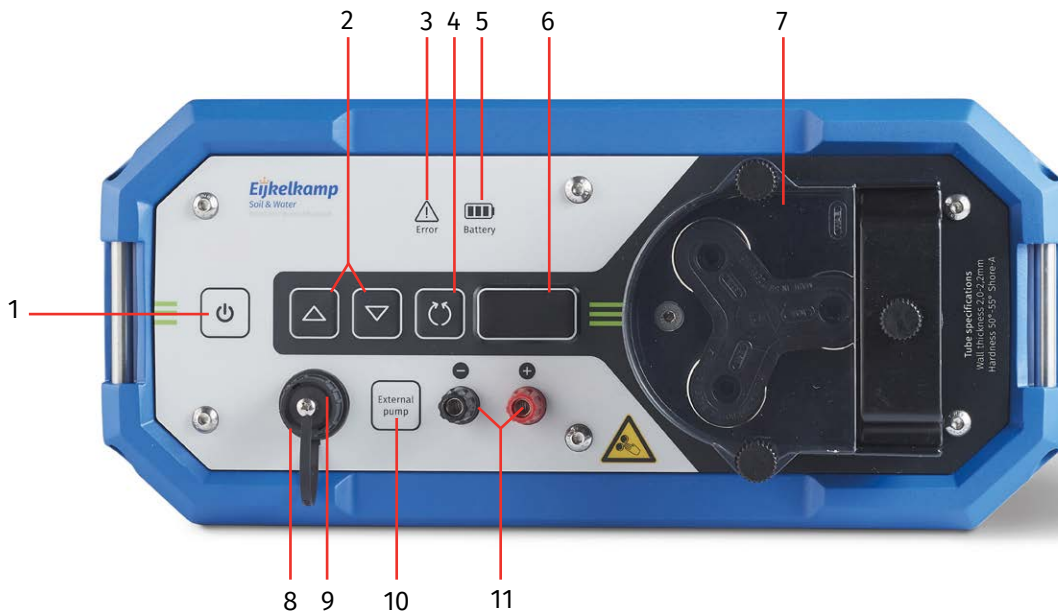

- |  |  |
|--|--|
| 1. On/off key with indicator                               | 7. Pump housing (with cover plate) with pressure rollers for flexible pump tube                                    |
| 2. Speed control keys                                      | 8. Waterproof sealing cap  |
| 3. Pump error indicator                                    | 9. Connection for external power supply/charger/external sounding device with inversion switch/firmware update USB |
| 4. Pump rotation direction                                 | 10. Selection switch internal/external pump  |
| 5. Battery indicator                                       | 11. Connection for external pump   |
| 6. Display for speed, battery capacity, and error messages |  |

Fig. 1 Overview of control panel – peristaltic pump 12 VDC Advanced

### 3.1 Switching on

Switching the peristaltic pump on and off is done with the on/off key (figure 1 position 1). After switching on, the green indicator in the upper-left corner will light up. For safety reasons, the pump will not start running immediately after it has been switched on.

### 3.2 Direction of rotation

The standard direction of rotation after switching on the peristaltic pump is clockwise. Use the rotation direction key (position 4) to select the desired rotation direction of the pump. The rotation direction can be changed during pumping without stopping the pump first. When the rotation direction is changed, the speed will first decrease to 0, then the pump changes rotation direction, and finally the speed will increase again to the original value.

### 3.3 Revolutions per minute RPM

The ▲ speed control key (2) increases the speed (shown on display 6). Pressing the membrane key once will increase the speed by 10 rpm. When pressed and held, the speed gradually increases to the maximum speed of 400 rpm in approximately 5 seconds. The ▼ key decreases the speed in the same way. The on/off button (1) is used to switch off immediately.

If the pump is not used for an hour and the speed is zero, it will automatically switch off.

An estimate of the flow rate the pump is delivering can be made based on the rotation speed. The precise flow rate depends on the groundwater level and the type and length of tube used.

### 3.4 Use of tube



**The transparent cover plate (7) must always be on the pump. This is necessary for safe operation and prevents penetration of moisture and dirt that could damage the bearings.**



**Attention: the pump is very powerful; never put your fingers in a running pump!**

#### 3.4.1 Type of tube

A flexible pump tube is placed in the pump housing (7). Usually silicone tube is used as a pump tube and polyethylene tube is used as transport tube. The most commonly used combination is the 6 mm ID x 10 mm OD silicone tube and the 6 mm ID x 8 mm OD polyethylene tube. In principle, the thinner the pump tube, the greater the suction power, but the lower the achieved flow rate. A 4 mm ID x 8 mm OD pump tube can also be used in the pump housing (see table of consumables 1235 in chapter 6).

#### 3.4.2 Inserting the pump tube

Approximately 30 cm of flexible pump tube is required. This can be inserted in the following ways:

1. Switch the pump off and remove the transparent cover plate and pressure clasp from the pump. Fit the tube by rotating the pressure rollers and pressing the tube between the pressure rollers and the pump housing.
- OR
2. With the pressure clasp slightly loosened, the cover plate fitted and the pump running, feed the flexible tube into the pump housing. The tube is correctly drawn into the pump housing by the pump eccentric and comes out again in the rotation direction of the pump.



**The tube must be firmly clamped by the pressure clamp. Pump housing, rollers, and tubing must be dry and stay dry during pump operation.**

## 3.5 Additional features of the peristaltic pump

### 3.5.1 External pump connection

The pump is equipped with an external 12 V output (position 11) to which a 12 volt submersible pump (see table of consumables 1235 in chapter 6) can be connected. This output is protected for a maximum current draw of 6.0 A and can power a maximum of two of these pumps. The speed of the pumps can then be adjusted using the speed control buttons (2).



**It is not possible to run the peristaltic pump and an external pump at the same time.**

### 3.5.2 Start/stop system

The peristaltic pump is equipped with a 'start/stop system'. The start/stop system of the peristaltic pump can only be used in conjunction with a sounding device with inversion switch and a connection cable (item no. 123506) that is installed between the peristaltic pump and the sounding device. The start/stop system enables the pump to switch off automatically when the groundwater level in the monitoring well reaches a certain level while groundwater is being pumped out of the monitoring well. This level can be set by the hanging depth of the sensor of the sounding device. A sounding device with inversion switch is a sounding device with the selectable option:

- a signal on contact with water
- or
- a signal when there is no water

After connecting such a sounding device to the peristaltic pump, proceed as follows.

- Lower the sounding tape of the sounding device into the monitoring well to the maximum draw-down level.
- Set the switch on the sounding device to the 'Air+SW' position.  
The device stops continuously beeping.
- Switch on the peristaltic pump and adjust it to the desired flow rate.
- The pump will now automatically stop when the sensor of the sounding device no longer senses water (the continuous beeping signal sounds when it contacts air).
- Once the pump has stopped, the groundwater level will start rising again towards the original level, depending on the permeability of the soil. When the sensor contacts water again and the level returns to its original level, the pump will wait for 30 seconds and start pumping again.

The use of this start/stop system prevents the water drop from exceeding a set critical limit. This is a commonly included requirement in many groundwater sampling standards and protocols (such as NEN5744 or SIKB protocol 2002).

## 4. Troubleshooting and maintenance

### 4.1 Troubleshooting

The unit has integrated safeguards to prevent damage caused by overloading, short-circuiting, and improper use. A list of common problems is provided below. A worn pump head leads to less or insufficient compression of the pump tube, which reduces the yield.



**We recommend that the unit be maintained by Eijkelkamp Soil & Water regularly.**



- **The pump is switched on but the on/off indicator (1) is not lit.**
  - The battery is completely discharged. Charge or replace the battery according to the instructions (see sections 2.1 and 2.2).
- **The battery indicator (5) flashes rapidly (red).**
  - The battery is almost discharged: charge it or connect an external power supply.
- **The pump is stopped; battery indicator (5) flashes red when switched on.**
  - The battery is discharged; connect the charger. Switch the pump on again with the on/off switch (1).
- **The battery discharges quickly after charging.**
  - Connect the charger. The battery indicator (5) on the front panel should light up. If the indicator goes off again after a short time, the problem is most likely the battery.
  - The battery is worn out or defective and must be replaced.
- **The pump suction and pressure are insufficient.**
  - Pump housing and rollers are wet. Dry pump housing, rollers, and pump tube. Prevent the pump from getting wet again (cover the pump).
  - The tube is slightly twisted in the pump housing and is therefore running slightly alongside the rollers (this is most likely with the 4 mm ID x 8 mm OD tube). Relieve the tension in the tube by loosening and tightening the pressure clasp.
  - Check that you are using a pump tube with the correct specifications (see table in chapter 6).
  - Pump housing and/or rollers are deformed due to dropping or impact. Send pump to the Eijkelkamp Soil & Water service department.
- **The pump shuts down after a short while, the *Error* indicator (3) is on, and on/off indicator (1) is flashing.**
  - The motor is overloaded or something is preventing it from turning. The protection switches off the pump. Check that no sand has been sucked into the pump tube and that nothing else is obstructing the pump. Remove the cause of the overload first.
- **The internal motor is running, but the pump is not turning or the pump makes rattling/clicking noises.**
  - The coupling between the motor and pump shaft may be loose. Please contact the service department of Eijkelkamp Soil & Water for repair.
- **The *External pump* indicator (9) is flashing.**
  - The external pump function is selected but no external pump is connected; check the connection and switch off the indicator with the *External pump* switch (10).
- **The *Error* indicator (3) is flashing, but the pump continues to operate normally.**
  - There is condensation in the peristaltic pump housing; you should have the pump checked as soon as possible to prevent damage to the electronics. Send pump to the Eijkelkamp Soil & Water service department.

## 4.2 Maintenance

The unit is designed for sampling under field conditions.

Regularly clean the peristaltic pump, cover plate, rollers, and pressure clasp with a damp cloth (clean tap water). The front panel and housing can be cleaned with a soft damp cloth, optionally with a non-aggressive cleanser.



**If used intensively, it is advisable to have the pump serviced by the supplier once a year.**

## 5. List of materials and consumables

Item no.:	Description
1235SB	Peristaltic pump Advanced incl. 10 Ah battery, incl. charger
1235	Peristaltic pump Advanced excl. battery and charger
123501	Battery charger 100-240 VAC, 50-60 Hz
123503	Battery 10 Ah
123504	Software update cable
123505	Car charger cable 12 V
123506	Connection cable to sounding device with start-stop system
Connectable as external pump	
1212SA	Submersible pump set (low cost). Complete set for monitoring wells $\phi$ 40 mm, consisting of submersible pump "Gigant" (3x), booster pump (3x), extension cable, sample tube and battery with battery-charger. For sampling till a depth of 14.5 m.

### Consumables 1235

Item no.:	Description
122004	Polyethylene tube, 6 mm ID x 8 mm OD, roll of 100 m
122005	Polyethylene tube, 6 mm ID x 8 mm OD, roll of 200 m
122007	Polyethylene tube, 6 mm ID x 8 mm OD, roll of 200 m, 30 rolls
122008	Polyethylene tube, 8 mm ID x 10 mm OD, roll of 100 m
122046	Silicone tube, 4 mm ID x 8 mm OD, roll of 5 m*
122048	Silicone tube, 6 mm ID x 10 mm OD, roll of 5 m*

\* The pump is suitable for elastic pump tubing with a total (i.e. double) wall thickness of 4.0 to 4.4 mm. The stiffness of the flexible tube must be between 50° and 55° Shore A.

## 6. Technical specifications

Item	Specifications
<b>Housing</b>	
Housing dimensions (LxWxH)	350x325x155 mm (max.)
Weight excl. lithium battery	approx. 7 kg
Lithium-ion battery (LiFePO <sub>4</sub> ) 10 Ah	1.5 kg
Material, basic housing	HIPS
Inner housing	Stainless steel
<b>Tube</b>	
Pump tube material	Silicones
Hardness, pump tube	50 to 55° Shore A
Wall thickness	2.0 to 2.2 mm
Diameter, pump tube (ID x OD)	4x8 mm & 6x10 mm
<b>Pump characteristics</b>	
Suction height (depending on environmental factors) Tube, 4 mm ID x 8 mm OD Tube, 6 mm ID x 10 mm OD	8 to 9.5 mWC (metres water column) 6 to 9 mWC
Pump pressure (depending on environmental factors) Tube, 4 mm ID x 8 mm OD Tube, 6 mm ID x 10 mm OD	2.5 to 3 bar 2.5 to 3 bar
Minimum flow rate @ 10 rpm	approx. 50 ml/min.
Maximum flow rate (depending on elevation/influencing factors)	approx. 2000 ml/min.
<b>Electric</b>	
Prescribed lithium-ion battery (LiFePO <sub>4</sub> ) 7.5 to 10 Ah	12.8 VDC
External power supply	12 VDC 3.34 A
<b>Environmental conditions/conditions of use</b>	
Temperature	-10 to +40 °C
IP rating	At least IP66 (dustproof and waterproof)
Relative humidity	0 to 100%
<b>Certification</b>	
CE	CE compliant
Machinery Directive	2006/42/EC
EMC Directive	2014/30/EU
RoHS Directive	2011/65/EU
WEEE Directive	2012/19/EU

## 7. Environment and waste disposal



Always comply with local rules and regulations regarding the handling or disposal of non-reusable parts.



Always remove the battery first. See 2.2 Placement/replacement of the lithium-ion battery.

### 7.1 Correct disposal of the product



Do not dispose of the unit with other types of waste! This could potentially damage human health or the environment. Submit electrical equipment to a designated collection point.

### 7.2 Correct removal of the battery



Do not dispose of the battery with other types of waste! The lithium-ion battery contains substances that can be harmful to human health or the environment.

To protect natural resources and promote reuse of materials, separate batteries from other types of waste and recycle them through your local battery return system.



Never return the lithium-ion battery to your local dealer by air transport, as the battery contains lithium.

## Appendix 1: Fitting and removing the carrying strap

 Use the two supplied 3 mm hex keys.

1. Unscrew (anticlockwise) at least one of the socket head screws from each carrying strap pin.



2. Remove the carrying strap pin by pressing it out of the housing chamber with the hex key. Push the pin out of the hole until it reaches the position shown.

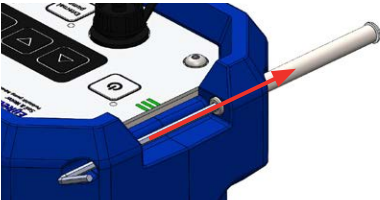

3. Fit the carrying strap as shown below.



4. Push the carrying strap pin back into position using the hex key, while twisting clockwise if necessary.
5. Refit the previously removed socket head screws by tightening them clockwise.

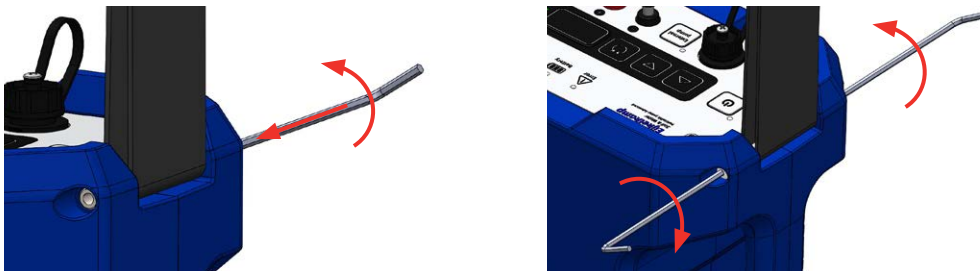

## Appendix 2: Operation membrane keys

Speed control keys.  
Per click, the peristaltic pump speed increases/  
decreases by 10 rpm

Direction of rotation  
pump clockwise/  
anticlockwise. Default  
after switching on is  
clockwise.

Pump error indicator.  
Overload warning (e.g.  
pump obstructed). Remove  
obstruction and reset with  
On/Off key.  
Warning for condensation  
in peristaltic pump housing.  
Send pump to the Eijkelkamp  
Soil & Water service  
department

Battery voltage  
indicator

On/Off  
key with  
indicator



Connection for external  
power supply/battery  
charger/external  
sounding device with  
inversion switch/  
firmware update USB

Selection switch internal/  
external pump.  
Press this key to activate  
the connection (e.g. to run  
submersible pumps).  
Speed of external pumps can  
be controlled via speed control  
buttons.

Connection for  
external pump(s)  
(12 VDC max. 6 A)

Display shows speed,  
error message, and  
charge percentage



## CE Declaration of Conformity

The undersigned, on behalf of the manufacturer:

Eijkelkamp Soil & Water BV  
Nijverheidsstraat 30  
6987 EM Giesbeek, The Netherlands



Hereby declares that the product:

Type: Peristaltic pump 12 VDC  
Item no.: 1235  
Function(s): The peristaltic pump is a self-priming water pump.  
The battery-powered pump is primarily intended for taking groundwater samples. The pump can be operated at an adjustable speed, allowing water sampling at very low flow rates, but also at higher flow rates of up to approximately two litres per minute.

complies with the essential requirements of the following EC directive(s) if installed in accordance with the installation instructions in the product documentation:

- Machinery Directive 2006/42/EC
- EMC Directive 2014/30/EU
- RoHS Directive 2011/65/EU
- WEEE Directive 2012/19/EU



and that parts of the standards and/or technical specifications listed below have been applied:

EMC Directive:

EN 61000-6-1: 2007 Electromagnetic Compatibility (EMC) - Part 6-1: Generic standards - Immunity standard for residential, commercial, and light-industrial environments

EN 61000-6-3: 2007 Electromagnetic compatibility (EMC) - Part 6-3: Generic standards - Immunity standard for residential, commercial, and light-industrial environments

Giesbeek (The Netherlands), June 2020

Manufacturer:  
Signature

Huug Eijkelkamp  
CEO