

# Geotech Product Recovery System

Installation and Operation Manual





## Table of Contents

Section 1: System Description .....	5
Section 2: System Installation .....	6
Section 3: System Operation .....	8
Section 4: System Maintenance .....	9
Section 5: System Troubleshooting .....	10
Section 6: System Specifications .....	11
Section 7: System Schematics .....	12
Section 8: Replacement Parts List .....	14
Warranty and Repair .....	16

## DOCUMENTATION CONVENTIONS

This uses the following conventions to present information:



### WARNING

An exclamation point icon indicates a **WARNING** of a situation or condition that could lead to personal injury or death. You should not proceed until you read and thoroughly understand the **WARNING** message.



### CAUTION

A raised hand icon indicates **CAUTION** information that relates to a situation or condition that could lead to equipment malfunction or damage. You should not proceed until you read and thoroughly understand the **CAUTION** message.



### NOTE

A note icon indicates **NOTE** information. Notes provide additional or supplementary information about an activity or concept.

## **Section 1: System Description**

### **Function and Theory**

The Geotech Product Recovery System (PRS) has been designed to efficiently collect free floating hydrocarbons in 2" (5 cm) or larger monitoring wells. The system consists of a stainless steel bladder pump, an attached Skimmer with floating intake cartridge (or buoy), a control panel that can be mounted indoors or out, a Tankfull Shut-off Sensor, air and discharge lines, and an optional air compressor (not included).

The PRS' unique product intake assembly, or Skimmer, incorporates both a density float and an oleophilic/hydrophobic filter that differentiates between floating hydrocarbons and water. The intake assembly follows the water table fluctuations and places the screen at the water/product interface, skimming light product (such as gasoline or diesel fuel) down to a sheen within the range of the float travel.

As the system cycles, product is drawn through the intake screen and is transferred to the pump through a coiled hose and the Skimmer's transfer shaft. Optional heavy oil and high temperature Skimmers, using intake buoys, are also available to recover product in 4" (10 cm) diameter and larger wells.

The pneumatic control panel regulates the system and features two timers which vary the cycle time and flow rate of the Skimmer pump. The control panel also contains a level control valve (to which the Tankfull Shut-off Sensor connects) that will shut off the pump when the recovery tank is filled.

The automatic stainless steel bladder pump has a two-phase pumping cycle. During the first phase, or pump intake phase, pressurized air is vented from the pump, thus creating a vacuum. This vacuum closes the top discharge check valve and opens the bottom intake check valve, causing product to be drawn through the Skimmer's product intake assembly and into the pump.

During the second phase, or pump discharge phase, pressurized air is directed into the pump bladder, causing it to expand within the pump body. This action closes the bottom intake check valve and opens the top discharge check valve, thus forcing the recovered product from the pump up to the surface.

### **Specific Gravity and Viscosity Limitations**

The specific gravity of the product to be recovered must be less than 1.0 and its viscosity less than 50 SSU for use with the "light" oil filter, and 400 SSU for use with the "heavy" oil filter cartridge. Consult Geotech for product recovery operations with viscosities outside that range.

This type of filter technology is designed to be used in wells with free product of at least 1/8" (3 mm) thickness.

The presence of surfactants or detergents in the product requires careful application. When confronted with these contaminants please consult Geotech.

## System Components

### Pump

The PRS utilizes an air driven bladder pump. The pump consists of a stainless steel outer housing, top and bottom check valves, and a flexible inner bladder. The pump is designed for pumping liquids only; any solids (silt, dirt, etc.) may reduce its performance or cause the pump to malfunction.

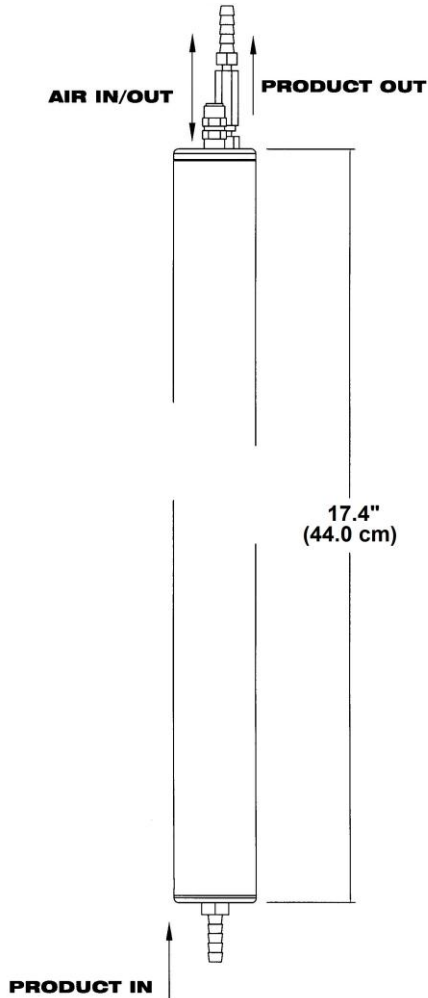

Figure 1-1 – PRS Pump

## Skimmer Attachments

A standard Skimmer attachment (when connected to the stainless steel pump assembly) is designed for use in either 2" (5 cm) diameter wells or 4" (10 cm) diameter and larger wells. Figure 1-2 shows an example of the two most common Geotech Skimmers. These Skimmers come with a standard 100 mesh intake screen. A 60 mesh intake screen is also available for use with higher viscosity fluids. See Geotech Manual "Hydrocarbon Viscosity Test Kit" for more information on choosing the correct intake cartridge.

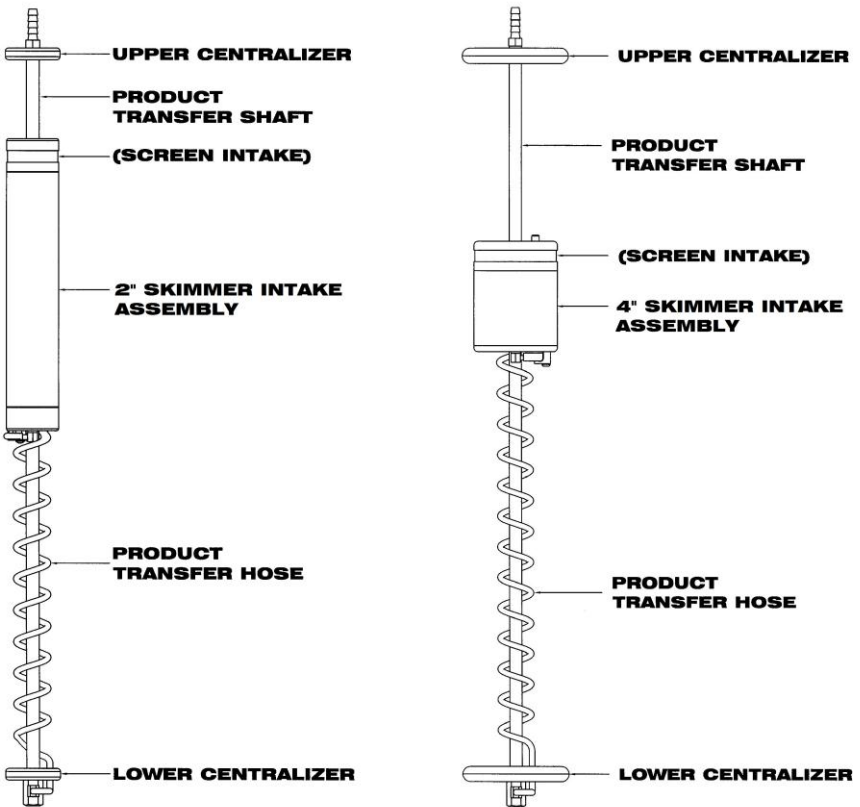

Figure 1-2 – Standard 2" and 4" Skimmer Attachments

The Skimmer assembly is connected to the bottom of the stainless steel pump with a 6" (15 cm) piece of durable, fuel grade hose. The Skimmer consists of a product intake float, a coiled product transfer hose, and a transfer shaft. Well centralizers are placed at the top and bottom of the Skimmer shaft to protect the intake float and to allow unobstructed travel within the well. Standard Skimmers can provide 12" (30 cm) to 24" (61 cm) of intake travel. Geotech can provide up to 5' (1.5 m) of travel (4" Skimmers only) on a custom order basis.



A Skimmer assembly will not draw water unless the intake cartridge is forcibly submerged, surfactants are present, or when the "conditioning" of the intake screen has been removed. See Section 4 for information on reconditioning the intake screen.

### **Heavy Oil Skimmer Attachment**

The optional heavy oil Skimmer attachment is designed to recover a range of fluids from gasoline to gear oil, skimming the product down to .01 feet (3 mm) in 4" (10 cm) diameter and larger wells. This option is best suited when the viscosity of the hydrocarbon is greater than the capability of the filter screen technology (screen can no longer pass the hydrocarbon fluid).

The heavy oil Skimmer consists of a polypropylene intake buoy, a coiled product transfer hose, and a transfer shaft with well centralizers placed at the top and bottom. The intake buoy on the heavy oil Skimmer is designed to "ride" at the oil water interface and has a travel range of 24" (61 cm).

The intake buoy can also be "fine-tuned" by adjusting the intake fitting on the top of the buoy. Turning the fitting clockwise will lower the intake fitting relative to the product/water interface. Turning the fitting counter-clockwise will raise the intake fitting away from the interface. Figure 1-3 is an example of a heavy oil Skimmer assembly.

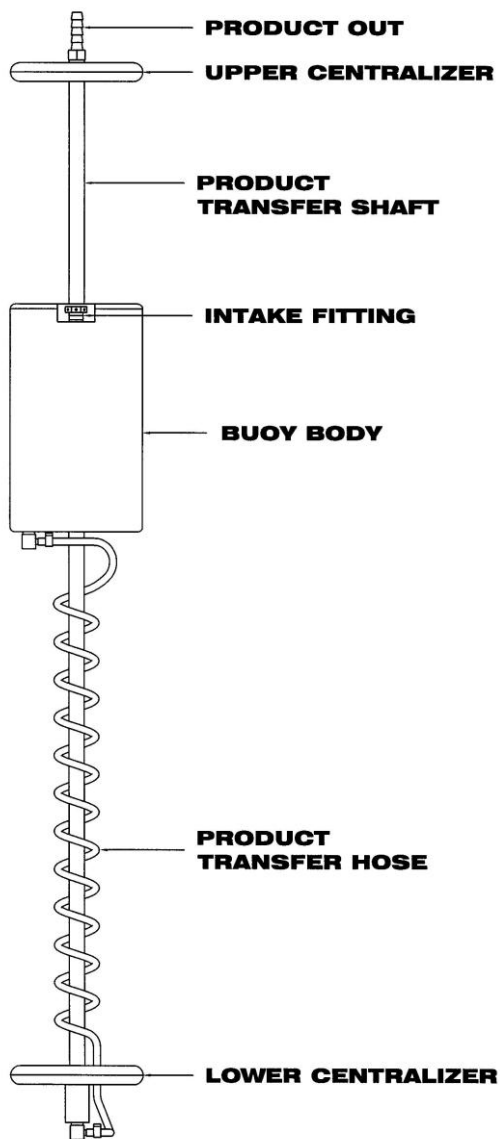

Figure 1-3 – Heavy Oil Skimmer Attachment (optional)

## PRS System Control Panel

The air-driven pump controller is the "heart" of the Product Recovery System. The controller uses two timers to vary the pumping rate of the system, independently controlling the discharge time and the recharge time of the pump. A clean, dry air source that can deliver one cubic foot per minute (cfm) at 90 psi (or .03 cmm at 6 bar) will adequately allow the controller to drive one pump. Up to four pumps can be run from one controller with a commercial air supply of at least 4 cfm (.11 cmm) at 90 psi (6 bar).

The PRS Control Panel comes equipped with a Tankfull Shut-off feature. The Tankfull Shut-off incorporates a manual reset button, as an additional safety feature. When the product recovery tank becomes full the Tankfull Shut-off Sensor shuts off the system. The reset button must be pushed and the system reset to resume operation.

The Tankfull indicator is green when the system is operational and is black when the system is shut-off. The recovery tank must be emptied and the reset button pushed before the system can be reactivated, and the indicator to show green.



Figure 1-4 – PRS System Control Panel

## Product Recovery Tank (not provided with the Product Recovery System)

A product recovery tank with a 2" NPT bung opening for the Tankfull Shut-off Sensor tube, a product inlet opening, and a vent are required for proper operation – typically a 55 gallon (208 liter) drum or other suitable container. Check government regulations regarding fuel storage before selecting a recovery tank.

### Tankfull Shut-off Sensor

The Tankfull Shut-off Sensor assembly (Figure 1-5) consists of a sensing tube that is connected to the control with a sensor air line. The control needs to be within 50' (15 m) of the discharge tank.

When the product rises approximately 11" (28 cm) up the side of the sensing tube, the level control valve within the control panel shuts off the air supply to the pump. Once the tank is drained, the system can be reset and resume normal operation.

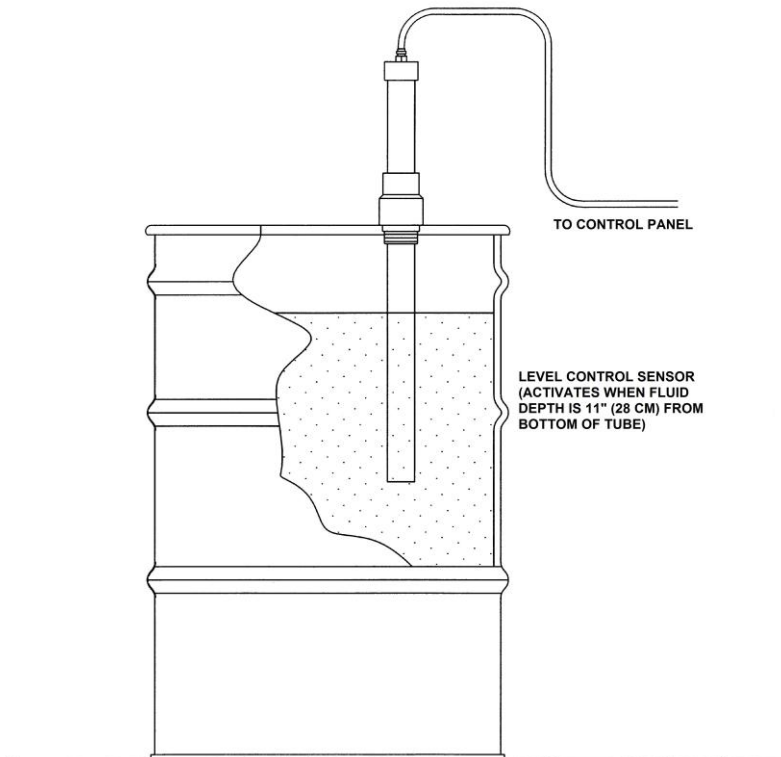

Figure 1-5 – Example of the Tankfull Shut-off Sensor (recovery tank not supplied)

## Air Line and Discharge Hoses

Typically, conduit or 2" (5 cm) PVC pipe, buried below grade, should be used to protect the air and discharge lines from damage. Failure to safeguard the air and discharge lines may lead to uncontrolled pump discharge and/or compressor failure. The discharge port of the pump accepts standard 1/4" NPT and 1/2" FPT pipe threads. Check government regulations regarding fuel transmission lines before installation of product discharge lines. The dimensions of air-line and hose to the listed devices are as follows:

Compressor	3/8" O.D. x 50 ft / 9.5mm x 15m
Pump Air Line	1/4" O.D. x 100 ft. / 6mm x 30m
Product Discharge Line	5/8" O.D. x 100 ft. / 16mm x 30m
Controller to Tank Full Shut off Sensor	1/4" O.D. x 50 ft / 6mm x 15m

## Optional Air Supply

The optional oil-less air compressors are supplied ready to use. Oil lubricated air compressors usually require the installation of the intake air filter and the filling of the oil sump before operation. The filter and appropriate oil are included with the compressor. Refer to the instructions provided with the air compressor for set-up procedures.

The oil-less air compressors require a 115V, 15 amp circuit. The oil lubricated air compressors require at least a 115V, 20 amp circuit (depending on the model). Avoid using extension cords or plugging other equipment into the same circuit as the air compressor.

An automatic tank drain and an air dryer may be required for the air compressor if the system is operating in humid conditions. Bottled air may be used to operate the PRS if operating an air compressor is not feasible. A high pressure regulator must be used to reduce the air pressure to the range of 60 psi (4 bar) to 100 psi (6.9 bar). Pressures outside of this range may cause the system to malfunction.



The air compressor must be protected from the elements and kept as cool as possible. If placing the compressor in an enclosure, it must be well ventilated and a fan may be required for proper cooling.

## Planning Your PRS Installation

To successfully plan the installation of the Product Recovery System, use the following guidelines to determine a suitable location for the control panel, pump, (optional) air compressor, Tankfull Shut-off Sensor, and recovery tank (not provided). Also refer to the System Schematic found in Section 7.

1. The standard PRS system does not include an air source. When installing an air compressor, do not locate the compressor in areas where there may be explosive vapors. Compliance with Section 5 of the U.S. National Electric Code Handbook and any local codes is essential for an electrically safe installation. The compressor requires a cool, well ventilated environment to operate efficiently, and may require an air dryer in freezing or humid environments.
2. The product recovery tank should be located within 50' (15 m) of the control panel when the Tankfull Shut-off Sensor is used.
3. Run all air and discharge hoses through pipe or conduit to protect them from damage. All air and discharge hoses must be installed correctly for the system to operate properly. The cut ends of the hoses must be straight, and the connections leak free. When inserting the air lines into the compression fittings, push the air line firmly into the fitting, hand tighten the compression nut, and then tighten one more full turn with a wrench.

## Section 2: System Installation

### Install Control Panel

Install control panel vertically on hard surface or post.

### Install the Pump and Skimmer to the well



Prior to installation, it is best if the screen intake is “conditioned”. Use diesel fuel or similar hydrocarbon to saturate the screen portion of the intake. The optimum fluid would be the downwell hydrocarbons to be recovered. Take care to avoid damaging the screen intake.

Remove the inner ring of the well cap, and secure it to the well casing using the three set screws located on the perimeter of the ring (for those systems using a well cap).

Cut a length of the provided air line and connect it from the output of the air compressor to the port labeled “INPUT FROM AIR SUPPLY” on the control panel.

To calculate the amount of air line and discharge hose required to suspend the pump and Skimmer in the well, first determine the static water level in the well, then subtract 46” (117 cm), 38” (97 cm) for the 2” Skimmer, from the reading. Next, measure out this amount of air line and discharge hose.

Do not make any cuts to tubing until all measurements between controller and well head and well height to recovery tank are made. Last, pull the measured lengths of air line and discharge hose through the fittings on the well cap. Fully tighten the compression fittings. The well cap will suspend the pump and skimmer by the discharge hose, setting the intake assembly at the midpoint of its travel range.

Attach the air line and discharge hose to the pump using the provided compression fitting and hose clamp respectively, and set the pump and skimmer in the well.

Connect the free end of the pump air line to the controller fitting labeled “OUTPUT TO PUMP”.

Connect the free end of the product discharge hose to the product recovery tank.

Install the Tankfull Shut-off Sensor air line between the Tankfull Shut-off Sensor tube and the controller fitting labeled “INPUT FROM TANKFULL SHUT-OFF SENSOR”.



See Figure 2-1 for a view of the pump and Skimmer in relation to the well cap and static water level.

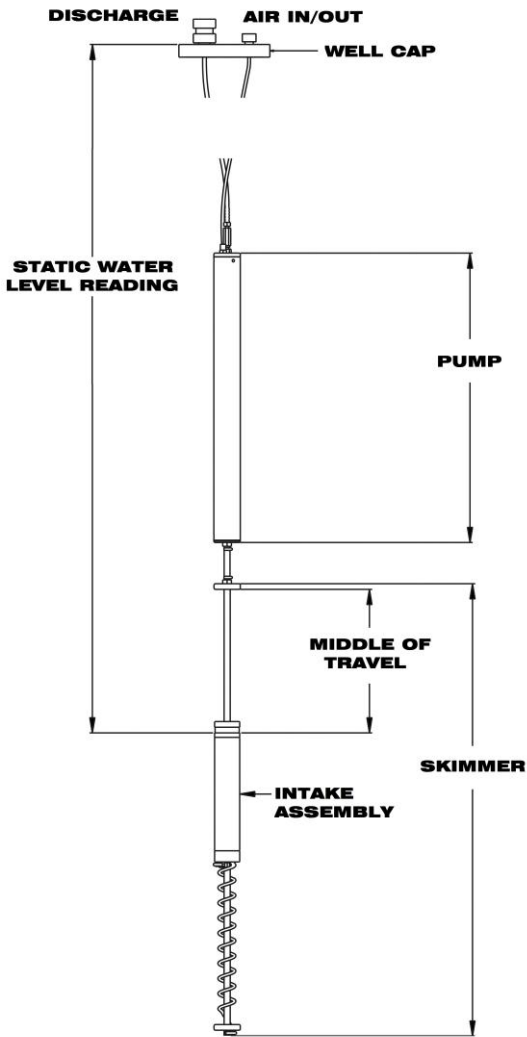

Figure 2-1 – Pump and Skimmer Assembly

### Section 3: System Operation

Start the air compressor. If the air compressor was supplied by Geotech, two pressure gauges, a pressure switch, an air valve, and a pressure regulator are located on the top of the compressor air tank(s). The main pressure gauge shows the total tank pressure, and the outlet pressure gauge (Figure 3-1) shows the outlet air pressure set by the regulator. The pressure switch has a lever with two positions. Move the lever to the “AUTO” (down) position, and the compressor will run until the tank pressure reaches 120 psi (8.3 bar). Turn the air valve on and verify that the pressure shown on the outlet pressure gauge reads between 80 psi (5.5 bar) and 100 psi (6.9 bar). If the setting is outside of this range, adjust the pressure by rotating the knob on the regulator.

Verify that the controller’s pump intake and pump discharge timers are on the “C” setting as indicated on the controller faceplate. Turn the air valve on the control panel to the “ON” position. The system will now begin to cycle and recover product.

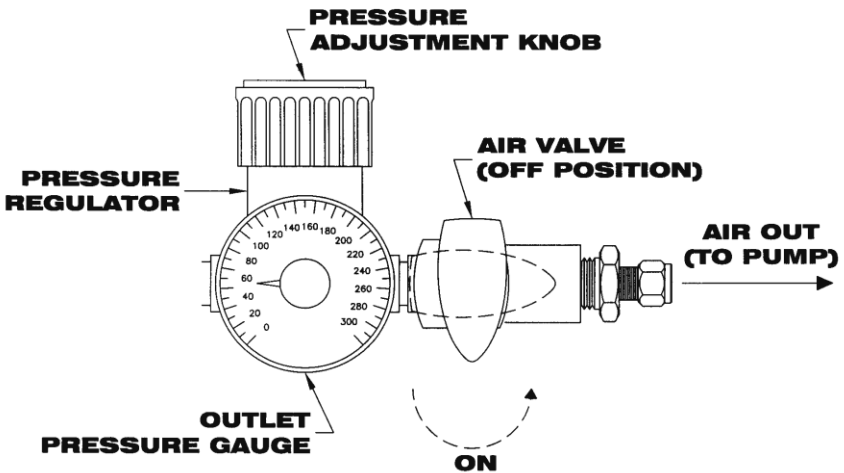
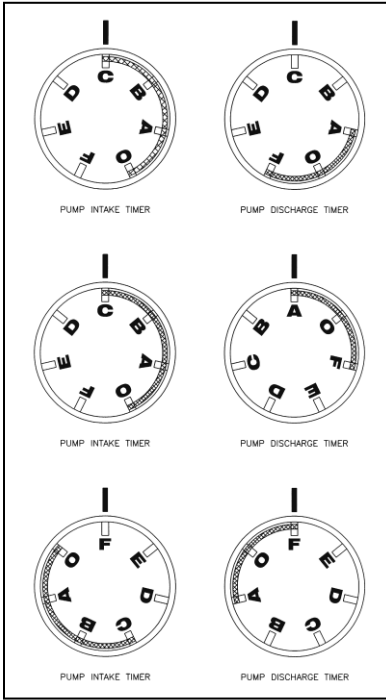

Figure 3-1 – Air Supply

Test the Tankfull Shut-off Sensor by immersing the sensor tube in a pail of water (at least 12” (30 cm) deep) while the system is cycling. Within one cycle, the sensor will shut off the air supply to the control panel. When you remove the sensing tube from the water, test to be sure the system remains off until the reset is pressed. If the system does not function as described, check the fittings at both the controller and sensing tube, and check for kinks in the sensor air line. Install the sensing tube in the 2” NPT bung opening on the discharge tank.

The pumping rate can be adjusted based on product volume. If there is a large volume of product, or a minimal amount of product in the well, the pumping rate may be adjusted by referring to the following illustrations. **DO NOT USE THE SETTINGS WITHIN THE SHADED AREA ON THE DIALS.**



A. Normal (default) setting

B. Maximum pumping rate

C. Minimum pumping rate

The pumping rate may be further reducing the system air pressure (45 psi (3 bar) minimum note: 60 PSI (4 bar) is required to operate bladder pump).

## Section 4: System Maintenance



Always ensure all hose and tubing fittings at the pump and between the pump and Skimmer are tight prior to deploying the unit into the well.

### Weekly Maintenance

- Turn the air compressor off and drain the air tank(s). On air compressors without an optional automatic condensate drain, open the drain fitting on the bottom of the compressor tank(s) and drain any accumulated water. The tank(s) must be drained regularly to avoid compressor malfunction.
- Check and adjust the compressor oil level (not applicable to all systems). Verify that the oil is at the proper level. Refer to the compressor manual for service intervals and procedures. It is very important that the oil level is maintained properly. If the oil level is too low or too high, the compressor may fail, or the pump may malfunction due to excess oil in the air stream.
- Inspect the compressor for loose fittings. Over time, vibration may cause bolts to loosen or air leaks to develop. If uncorrected, excess air consumption and shortened compressor life will result.
- Verify pump settings and fluid levels in the well. Make sure that the pump and skimmer are set at the correct interval for collection of free product.

### Monthly Maintenance

- Pull the pump and Skimmer from the well.
- Inspect all tubing for cracks, kinks and damage. Replace any old and brittle tubing.
- Inspect the coiled tubing for physical damage or obstructions. Verify the intake assembly moves freely over its travel range.
- Inspect the float (buoy) and intake screen. Clean the intake screen and float using the method described in this section.
- Inspect the Skimmer assembly for signs of physical damage. Scrapes or dents in the screen intake may cause the Skimmer to take on water. If such damage is found, a new 2" or 4" intake assembly may be necessary.
- Clear away any debris collected in the well vault (or above ground casement).
- Measure the well and record product layer thickness and depth to water from top of well casing.
- Place a pump positioning mark or zip tie on the discharge hose (usually black) even with the top of well casing.
- Re-deploy pump, aligning new depth to water mark on discharge hose with top of well casing.
- Check the tankfull shut off sensor for proper operation.

## **Quarterly Maintenance**

- Pull pump and Skimmer.
- Clean the well screen (site specific, primarily to clear bio growth and keep thick degraded product from impeding conductivity to the well at the product layer. Frequency to be determined by user).
- Place float assembly in water to verify the screen stays out of the water at the top of the traverse range. If it does not, replace the coiled tubing and retest. If it still does not, replace the float assembly.

## **Yearly Maintenance**

- Pull the pump and Skimmer from the well.
- Open pump and clean interior and parts with soapy water.
- Degrease the check disk and check ball seats. Spray with WD40 or kerosene.
- Clean and prime intake screen using the method described in this section.

## **Cleaning the Skimmer and Intake Screen**

Standard 2" and 4" Skimmers will usually come with a float containing a 100 or 60 mesh intake screen. When required, gently clean the screen with WD40 or kerosene, using a soft, bristle brush, to remove emulsified product, bio growth or other debris. Take care to avoid damaging the screen intake. Rinse the product intake assembly with clean water and make sure it is completely dry before reconditioning the intake screen.

For heavy oil Skimmers, use warm soapy water first, followed by WD40 or kerosene to remove debris or bio growth from the buoy body, then rinse and let dry.

Using warm soapy water, clean all debris and bio growth from the Skimmer shaft and coiled tubing.

## **Conditioning the Intake Screen**

Prior to initial deployment, and after every cleaning, the intake screen must be conditioned (or primed) with diesel fuel or other similar hydrocarbon. Use a soft, bristle brush to saturate the screen portion of the intake thoroughly. The optimum fluid would be to use the downwell hydrocarbons being recovered. Take care to avoid damaging the screen intake.

## **Bladder Replacement**

The pump is fitted with a field replaceable bladder for easy repair on the job site (see Figure 8-1).

1. Remove the lower pump housing from the upper control housing by unscrewing the two parts. Slide the lower housing off.
2. Unscrew the old bladder from the upper housing and screw on the new one. The bladder can be tightened snugly by hand.
3. Re-attach the lower housing to the upper pump assembly.

## Section 5: System Troubleshooting

**Problem:** The pump is only discharging water, not product.

### **Solutions:**

The water level has risen above the travel range of the Skimmer.

- Pull the pump and Skimmer out of the well. Purge the water out of the intake and pump by allowing the system to cycle for several minutes, prime the intake cartridge screen, then reset the pump and Skimmer.

The pump position has slipped, or the pump was installed below the water level in the well.

- Prime the intake cartridge screen , re-position the pump and Skimmer.

The intake assembly will not slide freely, or the coiled hose is tangled.

- Inspect the Skimmer assembly and repair as necessary.

Loose hose or tubing on fittings below intake level.

- Check all fitting connections.

**Problem:** The pump discharges air only, no product.

### **Solutions:**

Product has been removed.

- Reduce the pumping rate, or decrease the air pressure (45 psi minimum) to conserve air.

The Product layer is below the bottom of the skimmer's travel range.

- Reset the pump and skimmer.

The pump bladder has ruptured.

- Replace the pump bladder or contact Geotech for further information.

**Problem:** The pump cycles but does not discharge product.

### **Solutions:**

One or both of the pump check valves are malfunctioning.

- Remove and clean, or replace the check valves.

The viscosity of the product is too thick for the skimmer.

- Contact Geotech for other skimmer options.

The intake assembly is obstructed or the coiled product hose is kinked.

- Verify that the intake assembly moves freely over its travel range, and adjust the coiled hose if needed. Reset the pump and skimmer.

**Problem:** The pump discharges air only, no product.

**Solutions:**

Product has been removed.

- Recalculate and reduce the pumping rate at the control panel.

The product layer is below the bottom of the Skimmer's travel range.

- Adjust the position of the Skimmer assembly within the well.

The Skimmer assembly has detached from the pump (due to a cut hose or loose hose clamp.)

- If the Skimmer assembly cannot be “fished” from the well then a new Skimmer will be needed.

The pump bladder has ruptured.

- Replace the pump bladder. Refer to Section 8 or contact Geotech for further information.

**Problem:** The pump does not operate.

**Solutions:**

The product recovery tank is full.

- Empty the recovery tank then reset the control panel.

The air compressor's air valve is closed.

- Turn the valve on the air outlet of the air compressor to the “ON” setting and adjust the air to 85 psi (5.9 bar).

**Problem:** The compressor is not operating.

**Solutions:**

The fuse or circuit breaker trips continuously when used with an extension cord.

- Replace the fuse or reset the circuit breaker. Avoid using an extension cord, or use a larger gauge extension cord.

Electrical circuit not rated for compressor operation.

- Use a circuit with larger amperage rating.

The air compressor has an electrical problem.

- Contact the air compressor manufacturer directly or contact Geotech for further information.

**Problem:** The air compressor runs constantly.

**Solutions:**

There is an air leak in the air compressor or air line.

- Inspect the air compressor and air lines, and tighten fittings or replace the air line as needed.

The air compressor has a mechanical problem.

- Contact the air compressor manufacturer directly or Contact Geotech for further information.

## Section 6: System Specifications

Application:	2" (5 cm) or larger recovery wells
Maximum Depth	180 feet (55 m)
Oil/Water Separation:	Oleophilic/hydrophobic mesh screen
Maximum Pressure:	120 psi (8.3 bar)
Operating Pressure:	60 psi (4 bar) min, 80 psi (5.5 bar) -100 psi (6.9) recommended
Discharge Line:	.375" ID x .5" OD (Polyethylene or fuel grade Synthetic Rubber)
Air Lines:	.170" x .25" OD x 50ft. (15 m)

### Control Panel

Size:	12" H x 10" W x 6" D (30.5 cm H x 25.4 cm W x 15 cm D)
Weight:	18 lbs. (8.2 kg)
Temperature:	32° to 100° F (0° to 38° C)
Min. Pressure:	45 psi (3 bar)
Max. Pressure:	125 psi (8.6 bar)
Max. CFM:	8 cfm (.23 cmm) @ 90 psi (6 bar)

### Stainless Steel Pump

Size:	23.5" L x 1.75" OD (59.7 cm L x 4.5 cm OD)
Weight:	4.5 lbs. (2 kg)
Materials:	303 and 304 SS, flexible tubing, PVC, and Brass
Air Line:	.170" ID x .25" OD (Polyethylene)
Discharge Line:	.375" ID x .5" OD (Polyethylene or fuel grade)

### 2" Skimmer Assembly

Size:	35.5" L x 1.75" OD (90 cm L x 4.5 cm OD)
Weight:	1.75 lbs. (0.8 kg)
Materials:	304 SS, Polyethylene, PVC, Polypropylene, and Brass Fittings
Effective Travel:	12" (30.5 cm) Standard Travel
Operating Temperature:	32° to 100° F (0° to 38° C)

Minimum fluid level to activate Skimmer = 15" (38 cm)

#### **4" Skimmer Assembly**

Size:	35.5" L x 3.75" OD (90 cm L x 9.5 cm OD)
Weight:	2.25 lbs. (1 kg)
Materials:	304 SS, Polyethylene, PVC, Polypropylene, and Brass Fittings
Effective Travel:	24" (61 cm) Standard Travel, up to 5 feet (1.5 m) available
Operating Temperature:	32° to 100° F (0° to 38° C)

Minimum fluid level to activate Skimmer = 9" (23 cm)

#### **4" Heavy Oil Skimmer Assembly**

Size:	40" L x 3.75" OD (102 cm L x 9.5 cm OD)
Weight:	2.5 lbs. (1.1 kg)
Materials:	304 SS, PP, and Brass Fittings
Effective Travel:	24" (61 cm) Standard Travel
Operating Temperature:	32° to 100° F (0° to 38° C)

Minimum fluid level to activate Skimmer = 15" (38 cm)

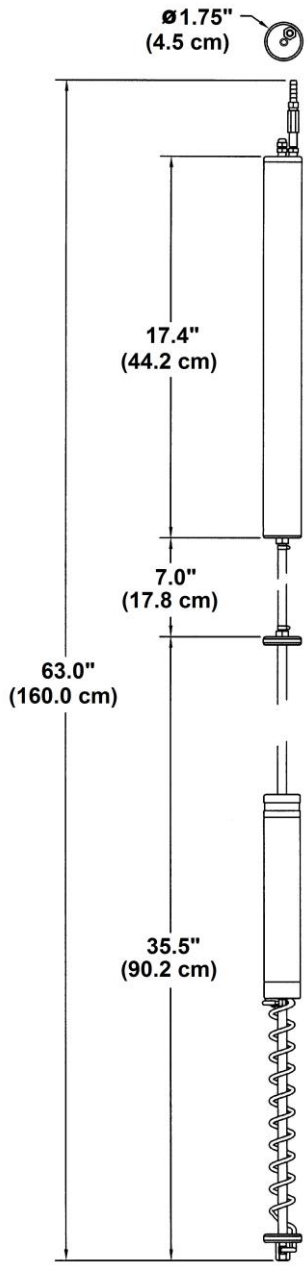

Figure 6-1

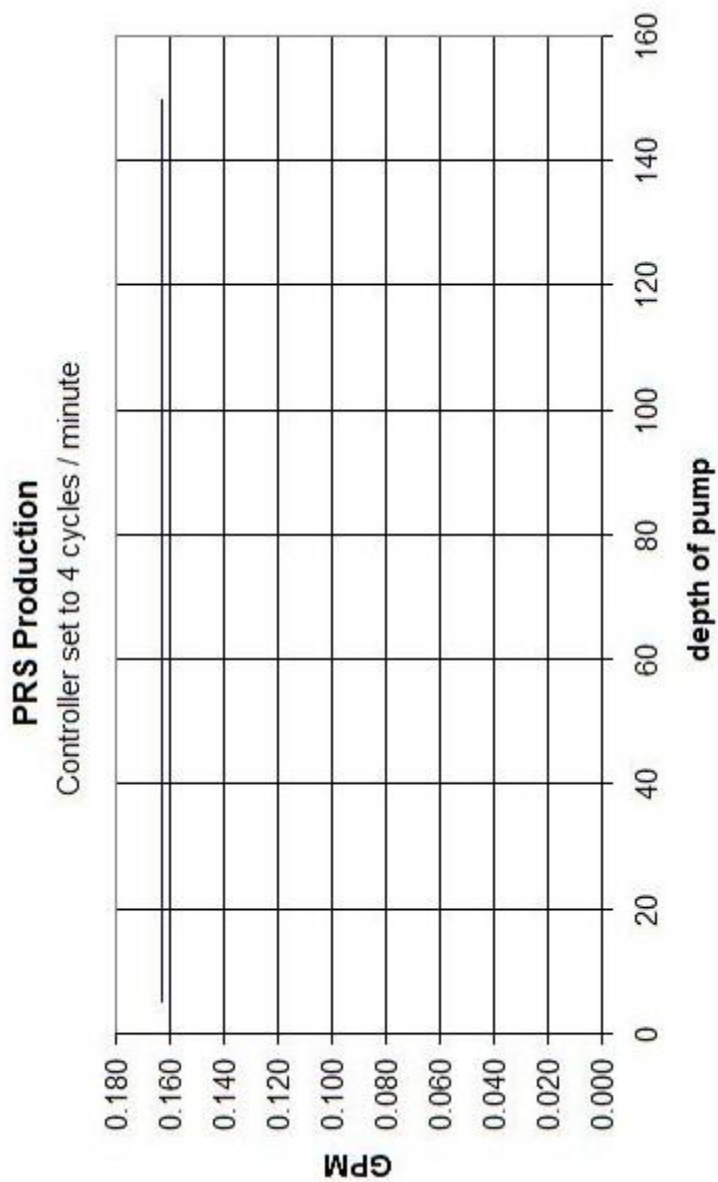

Figure 6-2

## PRS Air Consumption

Regulated air pressure = static head + 45 PSI

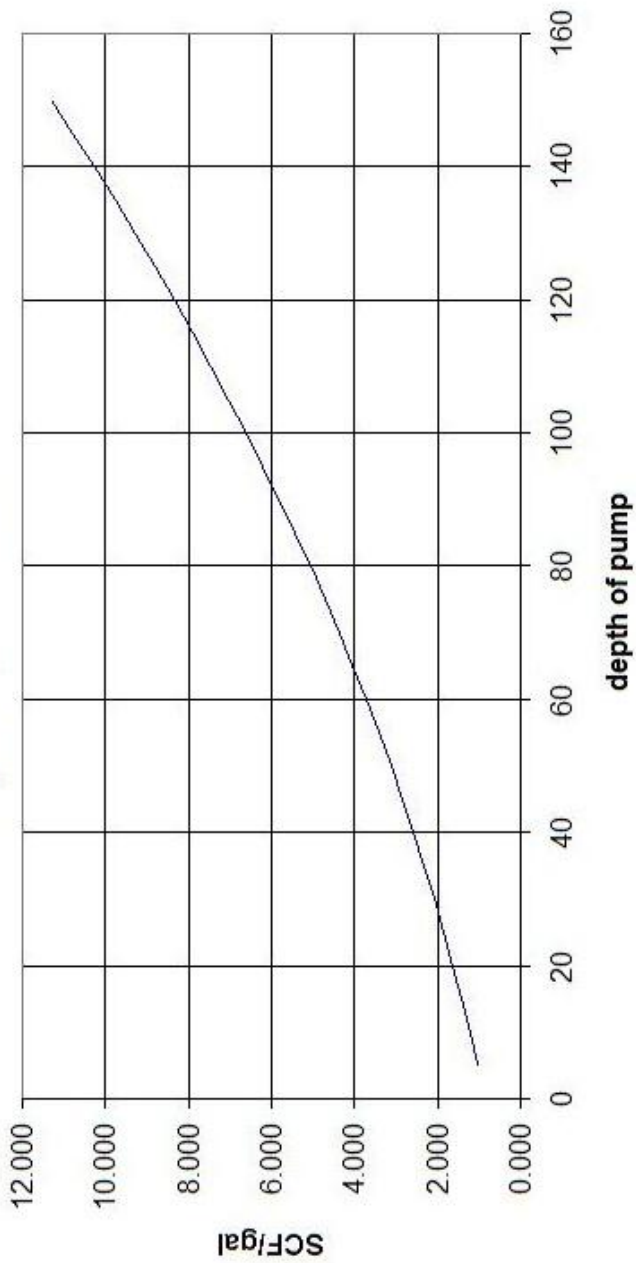

Figure 6-3

**PRS controller, exhaust times for smaller air line ID  
and lengths, 20' submergence**

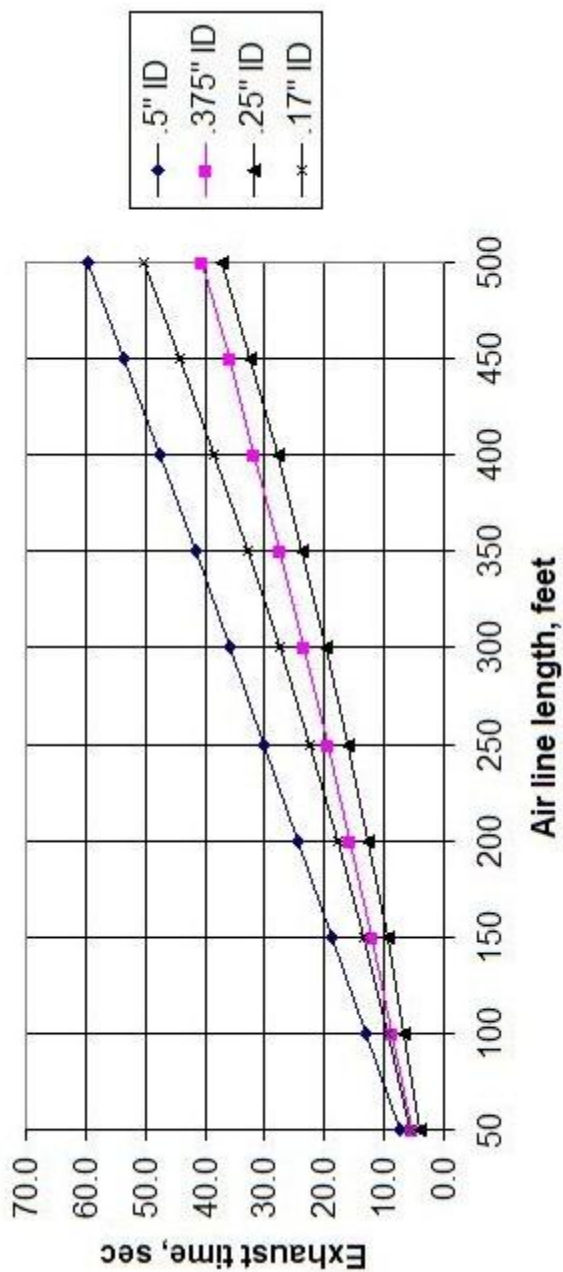

Figure 6-4

**PRS controller, exhaust times for larger air line ID and lengths, 20' submergence**

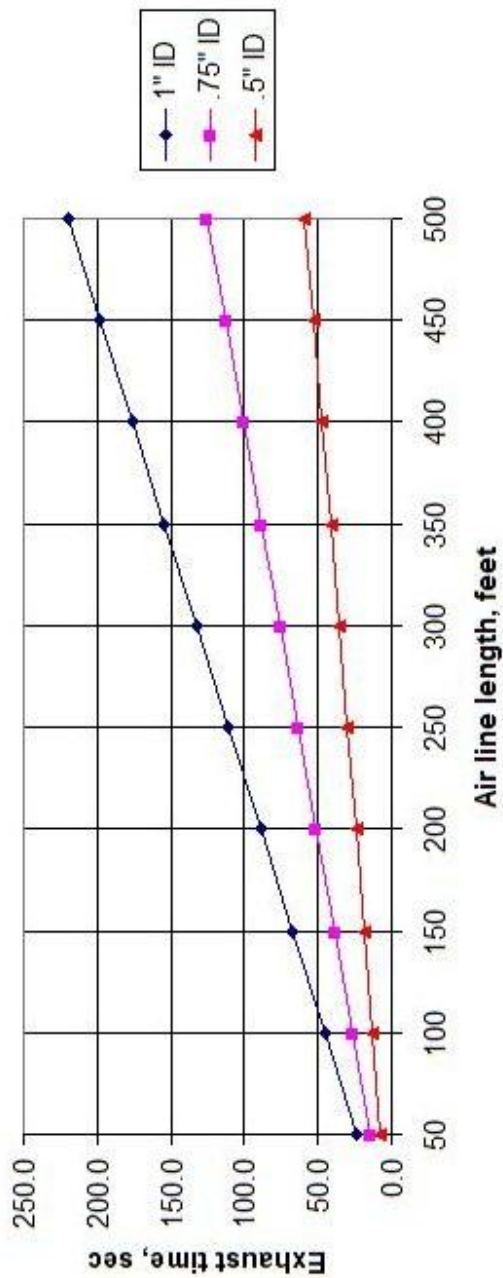

Figure 6-5

## Section 7: System Schematic

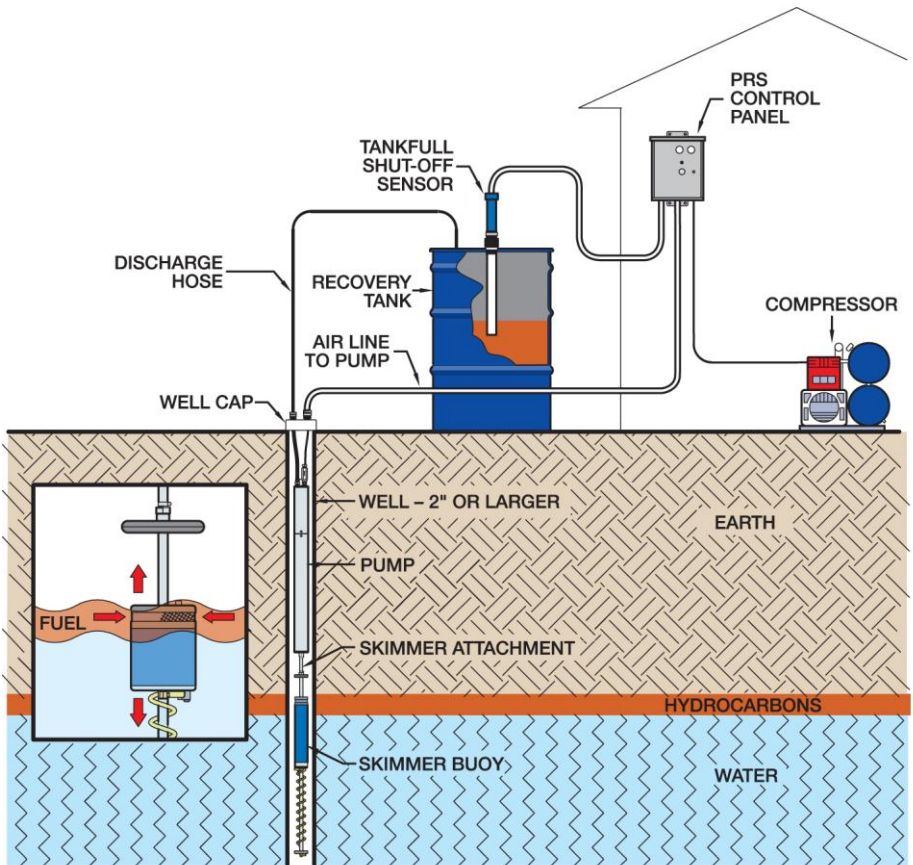

Figure 7-1 – Typical Site Installation with optional Tankfull Shut-off

Section 8: Replacement Parts List

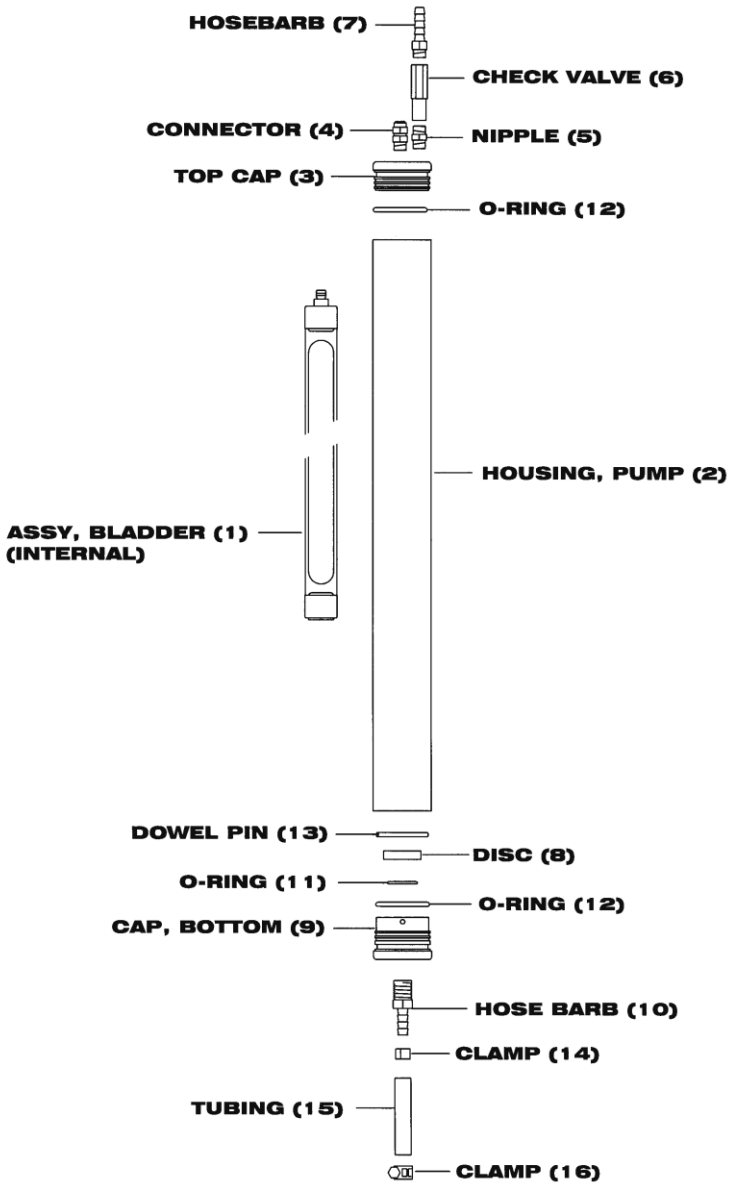

Figure 8-1 – Pump Assembly

## Stainless Steel Pump Assembly (56600002)

Item #	Parts Description	Parts List
1	ASSY,BLADDER,CRS/PRS	56600013
2	HOUSING,SS,PUMP,CRS/PRS	26600013
3	CAP, TOP, SS, CRS	26600019
4	TUBE, CONN, 1/4X1/8MPT, POLYTITE PUMP	16600037
5	NIPPLE, BRS, HEX, 1/8NPT	17500151
6	VALVE, CHECK, PRODUCT DISCHARGE CRS/PRS PUMP	26600157
7	HOSEBARB, BRS, 3/8"X1/8MPT	16650310
8	FLANGE, BLIND, PVC80, 8"	16600017
9	CAP, SS, BOTTOM, CRS/PRS	26600018
10	HOSEBARB, BRS, 3/8"X1/4MPT	16650323
11	O-RING, VITON, #208	16600023
12	O-RING, VITON, #128	16600030
13	PIN, SS, DOWEL, CHK DISK CRS/PRS	26600162
14	CLAMP, SS, STEPLESS EAR, 17MM	16600004
15	TUBING, RBR, 3/8x5/8, FT PRODUCT DISHCARGE	16600019
16	CLAMP, SS6, WORM, 7/32-5/8"	16600063

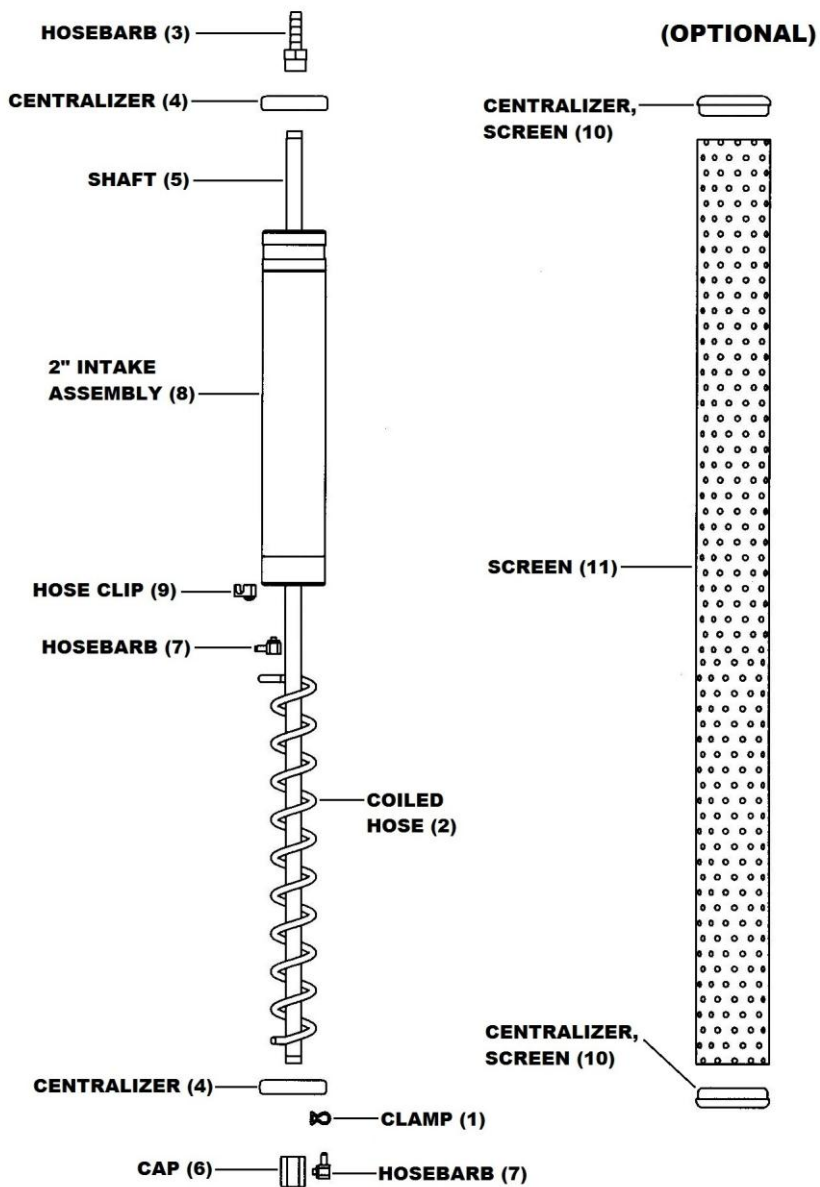

Figure 8-2 – Standard 2" Skimmer Assembly

## 2" Skimmer Assembly – 100 mesh (56600003)

Item #	Parts Description	Parts List
1	CLAMP,SS,STEPLESS EAR,7MM	16600005
2	HOSE,COILED,PR2	26650304
3	HOSEBARB,BRS,3/8"X1/8FPT	16650308
4	CENTRALIZER,PVC,SKIMMER,2"	26650306
5	SHAFT,SS,SKIMMER,33.5",PRC	26600002
6	CAP,BRS,1/8FPTx10-32 90 DEG	16600064
7	HOSEBARB,BRS,1/8"X10-32,90DEG	17500149
8	ASSY,BUOY,SKIMMER,2"100MESH	56650309
9	HOSE CLIP,SKIMMER FLOAT	26650028

## 2" Skimmer Options

8	ASSY,BUOY,SKIMMER,2" 60 MESH	56650312
10	CENTRALIZER,PVC,SCREENED PR2	26600186
11	SCREEN,SS,1.88"ODX32.7" STRAIGHT WELD	26600188

## Additional 2" Skimmers

	HOUSING,RECLAIMER,1.66,SS4,36"	56600064
	ASSY,SKIMMER,2",60 MESH	56600069
	ASSY,SKIMMER,2",60M,W/SCREEN	56600071

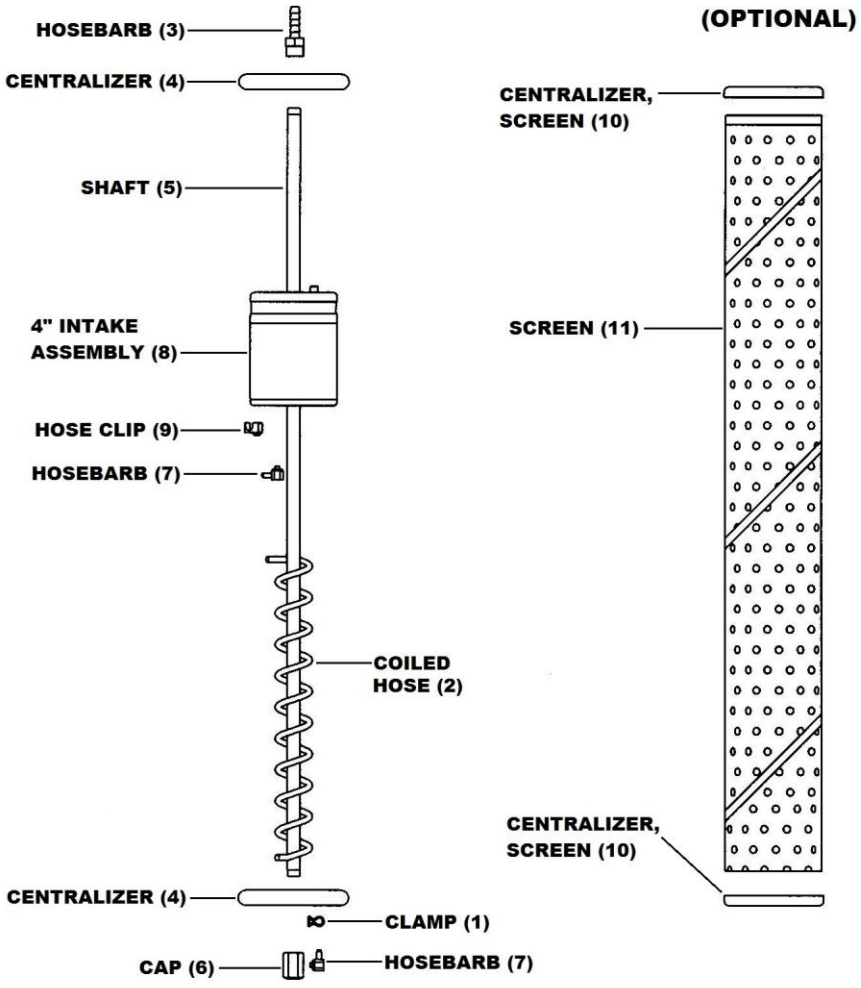

Figure 8-3 – Standard 4" Skimmer Assembly

#### 4" Skimmer Assembly – 100 mesh (56600004)

Item #	Parts Description	Parts List
1	CLAMP,SS,STEPLESS EAR,7MM	16600005
2	HOSE,COILED,PR4	16650312
3	HOSEBARB,BRS,3/8"X1/8FPT	16650308
4	CENTRALIZER,SKIMMER,PR4	16600048
5	SHAFT,SS,SKIMMER,33.5",PRC	26600002
6	CAP,BRS,1/8FPTx10-32 90 DEG	16600064
7	HOSEBARB,BRS,1/8"X10-32,90DEG	17500149
8	ASSY,BUOY,SKIMMER,4"100 MESH	56650310
9	HOSE CLIP,SKIMMER FLOAT	26650028

#### 4" Skimmer Options

8	ASSY,BUOY,SKIMMER,4" 60 MESH	56650313
10	CENTRALIZER,PVC,SCREENED PR4	26600187
11	SCREEN,SS,3.67" DIAM X32.7"	26600189

#### Additional 4" Skimmers

	ASSY,SKIMMER,4",100M,W/SCREEN	56600055
	ASSY,SKIMMER,4",100 MESH,5 FT EXTENDED TRAVEL	56600008
	ASSY,SKIMMER,4",60 MESH	56600070
	ASSY,SKIMMER,4",60M,W/SCREEN	56600072
	ASSY,SKIMMER,4",60 MESH,5 FT EXTENDED TRAVEL	56600073

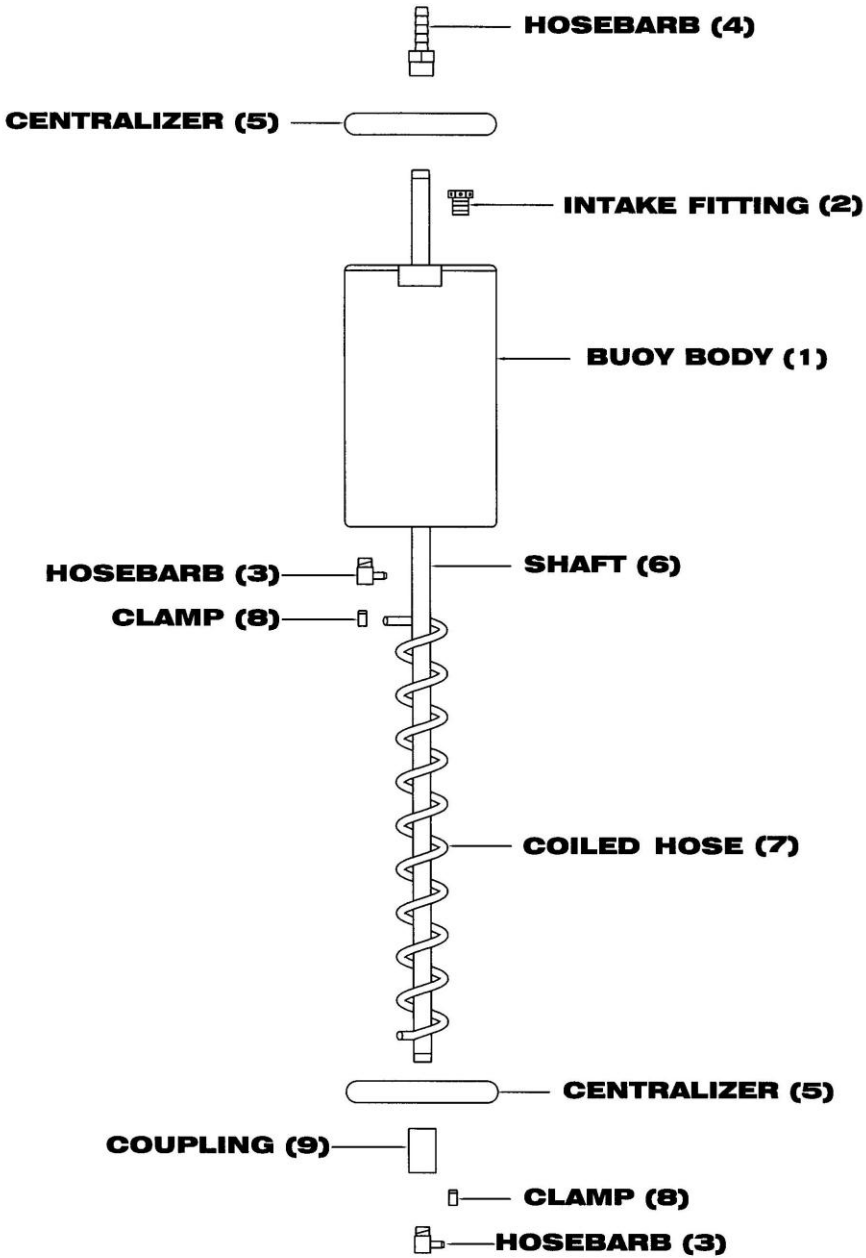

Figure 8-4 – 4" Heavy Oil Skimmer Assembly

#### 4" Heavy Oil Skimmer (56600005)

Item #	Parts Description	Parts List
1	BUOY,PP,HEAVY OIL	26600004
2	FTG,INTAKE,OIL BOUY	26600005
3	HOSEBARB,BRS,.170"X1/8MPT,90D	17500148
4	HOSEBARB,BRS,3/8"X1/8FPT	16650308
5	CENTRALIZER,SKIMMER,PR4	16600048
6	SHAFT,SS,OIL SKIMMER,38"	26600006
7	HOSE,COILED,OIL SKIMMER	26600007
8	CLAMP,SS,DBL PINCH,9/32-23/64"	11200273
9	COUPLING,SS4,.125"	16600006

#### 4" Heavy Oil Skimmer Options

ASSY,BUOY,OIL SKIMMER,4"	56600060
--------------------------	----------

#### Product Recovery System Accessories

Parts Description	Parts List
MANUAL,INSTRUCTIONS,PRS	26600008
PRODUCT RECOVERY SYSTEM,OIL, 4",PRS	86600005
PRODUCT RECOVERY SYSTEM,2"	86600007
PRODUCT RECOVERY SYSTEM,4",PRS	86600008
TUBING,RBR,3/8x5/8,100FT RL PRODUCT DISHCARGE	16600072
TUBING,NYL,1/4ODx0.040W,BLK	16600039
CLAMP,SS,STEPLESS EAR,7MM	16600005
CLAMP,SS6,WORM,7/32-5/8"	16600063
MANUAL,TEST KIT,HYDROCARBON VISCOSITY	26030001
TEST KIT,HYDROCARBON VISCOSITY	86020001

#### Tankfull Shut-off Sensors and Accessories

ASSY,TUBE,TANKFULL SENSOR,PVC W/ 50FT TUBING	56600061
TUBE,PVC,SENSOR,TANKFULL	26600077
ASSY,TUBE,TANKFULL SENSOR,SS CRS (SPOILER)	56600016
TUBE,SS,SENSOR,TANKFULL	16600074
NIPPLE,PVC80,2"NPTx6"L SENSOR TUBES	16600075
COUPLING,PVC,2"x1.5" PVC FLEXIBLE	16600078

# NOTES

# NOTES

## The Warranty

For a period of one (1) year from date of first sale, product is warranted to be free from defects in materials and workmanship. Geotech agrees to repair or replace, at Geotech's option, the portion proving defective, or at our option to refund the purchase price thereof. Geotech will have no warranty obligation if the product is subjected to abnormal operating conditions, accident, abuse, misuse, unauthorized modification, alteration, repair, or replacement of wear parts. User assumes all other risk, if any, including the risk of injury, loss, or damage, direct or consequential, arising out of the use, misuse, or inability to use this product. User agrees to use, maintain and install product in accordance with recommendations and instructions. User is responsible for transportation charges connected to the repair or replacement of product under this warranty.

## Equipment Return Policy

A Return Material Authorization number (RMA #) is required prior to return of any equipment to our facilities, please call our 800 number for appropriate location. An RMA # will be issued upon receipt of your request to return equipment, which should include reasons for the return. Your return shipment to us must have this RMA # clearly marked on the outside of the package. Proof of date of purchase is required for processing of all warranty requests.

This policy applies to both equipment sales and repair orders.

FOR A RETURN MATERIAL AUTHORIZATION, PLEASE CALL OUR  
SERVICE DEPARTMENT AT 1-800-833-7958.

Model Number: \_\_\_\_\_

Serial Number: \_\_\_\_\_

Date of Purchase: \_\_\_\_\_

## Equipment Decontamination

Prior to return, all equipment must be thoroughly cleaned and decontaminated. Please make note on RMA form, the use of equipment, contaminants equipment was exposed to, and decontamination solutions/methods used. Geotech reserves the right to refuse any equipment not properly decontaminated. Geotech may also choose to decontaminate the equipment for a fee, which will be applied to the repair order invoice.



**Geotech Environmental Equipment, Inc.**

2650 East 40th Avenue Denver, Colorado 80205

(303) 320-4764 • **(800) 833-7958** • FAX (303) 322-7242

email: [sales@geotechenv.com](mailto:sales@geotechenv.com) website: [www.geotechenv.com](http://www.geotechenv.com)