

***Innova Series
Operator's Manual***



PROPRIETARY STATEMENT

Thermo GasTech owns proprietary rights in the information disclosed within. By receiving this document, the recipient agrees that neither this document nor the information disclosed within nor any part shall be reproduced or transferred to other documents or used or disclosed to others for manufacturing or for any other purpose except as specifically authorized in writing by **Thermo** GasTech.

COPYRIGHT STATEMENT

Information contained in this document is protected by copyright. No part of this document may be photocopied, reproduced, or translated to another program or system without prior written authorization from **Thermo** GasTech., © 2002, **Thermo** GasTech.

TRADEMARK STATEMENT

Protected through use and/or registration in the United States and many foreign countries are the trademarks and service marks of **Thermo** GasTech. The use of the ® symbol indicates registration in the United States only; registrations may not have been issued at present in other countries. All other product names and logos are trademarks of their respective owners.

GASTECH® is a trademark of **Thermo** GasTech and is registered with the U.S. Patent and Trademark Office.

DISCLAIMER

Under no circumstances will **Thermo** GasTech be liable for any claims, losses, or damages resulting from or arising out of the repair or modification of the equipment by a party other than **Thermo** GasTech or its authorized service representatives, or by operation or use of the equipment other than in accordance with the printed instructions provided by **Thermo** GasTech or if the equipment has been improperly maintained or subject to neglect or accident. Any of the foregoing will void the warranty.

EXPORT STATEMENT

Export of the information and products in this manual from the U.S.A., or re-export from another country, may require written authorization from the U.S. Department of Commerce. Printed in the U.S.A.

REVISIONS TO MANUAL

All information contained in this manual is believed to be true and correct at the time of printing. However, as part of its continuing efforts to improve its products and their documentation, **Thermo** GasTech reserves the right to make changes at any time without notice. Any revised copies of this manual can be obtained by writing **Thermo** GasTech.

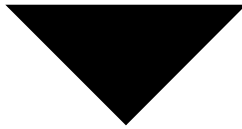

WARNING



THIS INSTRUMENT IS DESIGNED TO DETECT ONE OR MORE OF THE FOLLOWING:

FLAMMABLE VAPORS, OXYGEN CONTENT, AND/OR TOXIC GAS AND TO GIVE WARNING BEFORE THEY REACH HARMFUL CONDITIONS. IN ORDER TO ENSURE THAT IT WILL WARN OF DANGEROUS CONCENTRATIONS, IT IS ESSENTIAL THAT THE INSTRUCTIONS IN THIS MANUAL, PARTICULARLY THOSE CONCERNING START UP, OPERATION, CALIBRATION, AND MAINTENANCE, BE READ, UNDERSTOOD, AND FOLLOWED.

NOTATION CONVENTIONS

Notices are used in this operator's manual to alert you to hazardous conditions to person or instrument and to notify you of additional information. This operator's manual uses the following notices.



WARNING

Notifies you of potential danger that can result in personal injury or death.



CAUTION

Notifies you of potential damage to equipment.



NOTE

Notifies you of additional or critical information.



SERVICE POLICY

Thermo GasTech maintains an instrument service facility at the factory as well as authorized service facilities around the world. Should your instrument require service, you may contact us at:

Toll free: 1.877.GAS.TECH (USA)
In Canada: 403.291.4700

You may also visit our website to locate an authorized service locations.
www.thermogastech.com or www.thermogastech.ca (In Canada)

For warranty or non-warranty repairs, call us to complete a Return Material Authorization (RMA) form, obtain billing and shipping information and tell us the nature of the problem.

For non-warranty repairs, you will need to provide a purchase order number. If you need to set a limit to the repair costs, state a "Not to Exceed" figure. If you need a price quotation before you can authorize the repair costs, so state, but understand this will incur additional costs and may delay processing of the repair.

Enclose the copy of the RMA (Return Material Authorization) that was previously faxed to you. Pack the instrument and all its accessories (preferably in its original packing) and any special instructions.

Repairs are warranted for 90 days from the date of shipment. Sensors have individual warranties.



NOTE

Thermo GasTech assumes no liability for work performed by unauthorized service facilities.



WARRANTY STATEMENT

Thermo GasTech (the “Company”) warrants that the Products will operate substantially in conformance with the Company’s published specifications, when subjected to normal, proper, and intended usage by properly trained personnel, for a period of one (1) year after shipment to Customer (the “Warranty Period”). The Company agrees during the Warranty Period, provided it is promptly notified in writing upon the discovery of any defect and further provided that all costs of returning the defective Products to the Company are prepaid by Customer, to repair or replace, at the Company’s option, defective products so as to cause the same to operate in substantial conformance with said specifications. Replacement parts may be new or refurbished, at the election of the Company. All replaced parts shall become the property of the Company.

Lamps, pump diaphragms/valves, batteries, fuses, bulbs, and other expendable items are expressly excluded from the warranty.

The Company’s sole liability with respect to equipment, materials, parts, or software furnished to the Company by third party suppliers shall be limited to the assignment by the Company to Customer of any such third-party supplier’s warranty, to the extent the same is assignable. In no event shall the Company have any obligation to make repairs, replacements, or corrections required, in whole or in part, as the result of (i) normal wear and tear, (ii) accident, disaster, or event of force majeure, (iii) misuse, fault, or negligence of or by Customer, (iv) use of the Products in a manner for which they were not designed, (v) causes external to the Products such as, but not limited to, power failure or electrical power surges, or (vi) use of the Products in combination with equipment or software not supplied by the Company.

ANY INSTALLATION, MAINTENANCE, REPAIR, SERVICE, RELOCATION, OR ALTERATION TO OR OF, OR OTHER TAMPERING WITH, THE PRODUCTS PERFORMED BY ANY PERSON OR ENTITY OTHER THAN THE COMPANY WITHOUT THE COMPANY’S PRIOR WRITTEN APPROVAL, OR ANY USE OF REPLACEMENT PARTS NOT SUPPLIED BY THE COMPANY, SHALL IMMEDIATELY VOID AND CANCEL ALL WARRANTIES WITH RESPECT TO THE AFFECTED PRODUCTS.

THE OBLIGATION TO REPAIR OR REPLACE A DEFECTIVE PRODUCT SHALL BE THE SOLE REMEDY OF CUSTOMER IN THE EVENT OF A DEFECTIVE PRODUCT. EXCEPT AS EXPRESSLY PROVIDED IN THIS SECTION, THE COMPANY DISCLAIMS ALL WARRANTIES, WHETHER EXPRESS OR IMPLIED, ORAL OR WRITTEN, WITH RESPECT TO THE PRODUCTS, INCLUDING WITHOUT LIMITATION ALL IMPLIED WARRANTIES OF MERCHANTABILITY OR FITNESS FOR ANY PARTICULAR PURPOSE. THE COMPANY DOES NOT WARRANT THAT THE PRODUCTS ARE ERROR-FREE OR WILL ACCOMPLISH ANY PARTICULAR RESULT.

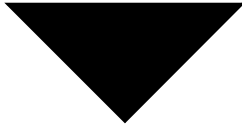



TABLE OF CONTENTS

Chapter 1

Introduction	
About the Innova Series	1
Specifications	2
Sensor Specifications	3
Optional Accessories	4

Chapter 2

Start Up & Operation	
Preparing for Start Up	5
Starting Up the Innova	6
Normal Operation	7
Turning Off the Innova	8
Performing a Bump Test on Power-Up	9

Chapter 3

Alarms	
Gas Alarms	11
Battery Alarms	12
Sensor Alarms	13
Pump Alarm	14
Datalog Alarm	15
Temperature Alarm	15

Chapter 4

User Program	
About the User Program	17
Display Menu	18
Accessing Password-Protected Menus	19
Advanced Features Menu	20
Datalog Features Menu	28

Chapter 5

Calibration	
Preparing the Calibration Kit	33
Calibrating the Innova	34
Calibration Alarms	39

Chapter 6

Maintenance	
Preventive Maintenance	41
Trouble Shooting	43
Recharging Ni-Cd Batteries	46
Replacing Components	47

Appendix A

Parts List and Accessories	53
--------------------------------------	----

Appendix B

Interference Factors	
High Concentration of Combustible Gas	57
Relative Combustible Response Table	59

Appendix C

Supplemental Instructions	
Innova Land Surveyor	61
Innova Transformer Gas Tester	65
Soil and Fuel Vapor	69

INTRODUCTION

About the Innova Series

The Innova Series (shown in Figure 1-1) is a line of portable gas monitors capable of detecting from one to four gases. It continuously computes average readings for Short Term Exposure Limit (STEL) and Time Weighted Average (TWA) levels. You can display Peak readings, STEL, and TWA levels on command. The Alarm circuit alerts you to dangerous gas conditions, low battery conditions, sensor failure, datalog full, calibration reminder, and sample-draw pump failures.

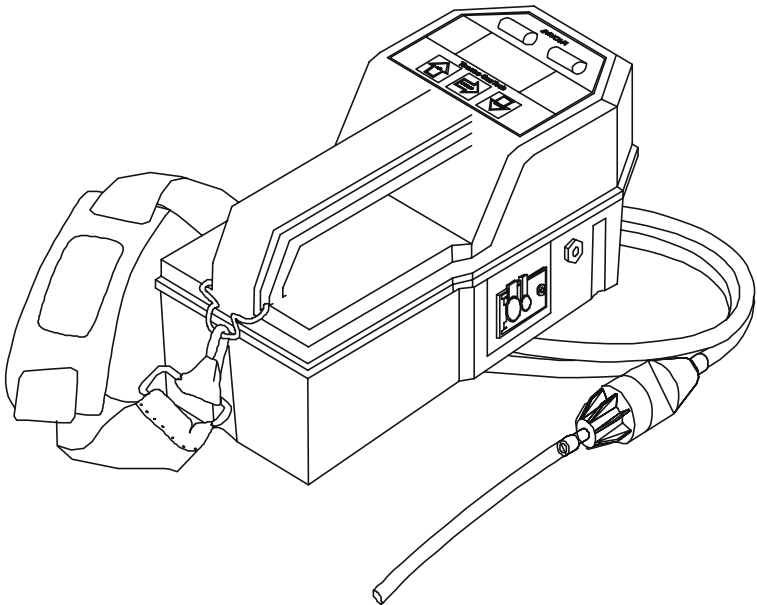

Figure 1-1 Innova Series Gas Monitor

The Innova is powered by four “D” size alkaline or nickel-cadmium (NiCd) batteries. A jack is provided on the Innova so you can connect the external NiCd battery charger.

Specifications

Table 1-1 lists specifications for the Innova Series gas monitor.

Table 1-1 Specifications for the Innova Series Gas Monitor

Intrinsic Safety Rating (Area Classification)	Class I, Division 1, Groups A, B, C, and D
Sampling Method	Sample-drawing
Response Time	Initial: 5 seconds average (with 5-foot hose) 90% complete within 30 seconds (except NH ₃) 90% complete within 150 seconds (NH ₃)
Operating Temperature	-4° F to 113° F (-20° C to 45° C)
Storage Temperature	-22° F to 149° F (-30° C to 65° C)
Humidity	0 to 95% relative humidity (RH), non-condensing
Regulatory Approvals	UL Classified; CSA Certified, Cenelec
Alarms	Audible/visible, coded for gas and trouble. Also a comfort beep that can be turned off.
Alarm Actions	Low flow; low battery; rising gas reading (rising or falling gas readings for oxygen); rising TWA and STEL reading (toxic versions only); sensor failure; temperature; datalog.
Alarm Functions	Alarm levels are user-selectable in the Edit Alarms Screen.
Display	Digital liquid crystal display (LCD). Displays up to four different gases at a time. A back light is available on demand by momentarily pressing any button.
Power Source	Four "D" size alkaline or NiCd batteries.
Battery life	Alkaline - 24 hours @ 68° F(20° C) Ni-Cd - 12 hours @ 68° F(20° C) Due to the nature of alkaline cells, battery life is greatly reduced at low temperatures and may be less than two hours at -15° C. NiCd batteries are recommended for low temperature applications.
Controls	AIR , ON/OFF (power), and RANGE buttons.
Dimensions	10 in. L x 5 in. W x 6 in. H (254 mm L x 152 mm W x 127 mm H)
Weight	5 pounds (2.25 kg)
Case	High-impact, chemical resistant polycarbonate-polyester plastic with RF-resistant coating.
Standard Accessories ¹	Shoulder strap; hose; probe (with filter); operator's manual; and quick reference card.

¹ Innova models for transformer testing include the following standard accessories: dilution fitting, and gas collection bag.

Sensor Specifications

Table 1-2 Innova Sensor Specifications and Factory Default Settings

Target Gas	Display Increments	Range	Low Alarm	High Alarm	TWA Alarm	STEL Alarm
HC	1% LEL	0 to 100% LEL	10% LEL	50% LEL	N/A	N/A
HC	0.1% VOL	0 to 5.0% VOL	0.5% VOL	2.5% VOL	N/A	N/A
HC	20 PPM	0 to 10,000 PPM	1000 PPM	5000 PPM	N/A	N/A
HC ¹	10 PPM	0 to 1,000 PPM	100 PPM	500 PPM	N/A	N/A
CH ₄ ²	1% VOL	0 to 100% VOL	10% VOL	50% VOL	N/A	N/A
O ₂	0.1% VOL	0 to 30.0% VOL	19.5% VOL	23.5% VOL	N/A	N/A
H ₂ S	1 PPM	0 to 200 PPM	10 PPM	15 PPM	10 PPM	15 PPM
CO	1 PPM	0 to 250 PPM	25 PPM	200 PPM	25 PPM	200 PPM
Cl ₂	0.1 PPM	0 to 9.9 PPM	0.5 PPM	1.0 PPM	0.5 PPM	1.0 PPM
HCN	1 PPM	0 to 30 PPM	5 PPM	10 PPM	5 PPM	10 PPM
NH ₃	1 PPM	0 to 100 PPM	25 PPM	35 PPM	25 PPM	35 PPM
NO	1 PPM	0 to 100 PPM	25 PPM	75 PPM	25 PPM	75 PPM
NO ₂	0.1 PPM	0 to 9.9 PPM	3.0 PPM	5.0 PPM	3.0 PPM	5.0 PPM
PH ₃	0.01 PPM	0 to 3.0 PPM	0.3 PPM	1.0 PPM	0.3 PPM	1.0 PPM
SO ₂	0.1 PPM	0 to 9.9 PPM	2.0 PPM	5.0 PPM	2.0 PPM	5.0 PPM

¹ Soil Vapor and Fuel Vapor only.

² Land Surveyor version only.

Optional Accessories

Table 1-3 lists the optional accessories available for the Innova Series gas monitor. Part numbers for all accessories are in Appendix A, Parts List and Accessories.

Table 1-3 Innova Series Optional Accessories

Accessory	Description
NiCd battery charger	Charges NiCd batteries while still in the monitor. Provides a full charge over an 8-hour period, then drops to a sustaining rate. Includes an alkaline recognition feature that prevents you from attempting to recharge alkaline batteries.
Optional hoses and probes	Lengths of hose up to 100 feet are available (except Cl ₂ versions). Two optional 30-inch probes (aluminum with dust filter or fiberglass with hydrophobic filter) are available.
Dilution fitting	Used to provide sufficient oxygen to allow proper response of the hydrocarbon (LEL/ppm) sensor when sampling inert environments.
Moisture trap	Glass-bodied with a pleated paper filter that collects excess water that is drawn into or condensed in the sample hose.
Auxiliary hydrophobic filter	A filter with a water-impervious membrane that connects between the sampling hose and the Innova's inlet fitting.
Remote Buzzer	Repeats all audible alarms of the Innova. Plugs into the remote alarm jack (CHGR). Includes clip to attach to lapel or other convenient place.
Carrying case	A case that holds the Innova and the most commonly used accessories. The case also has space to hold the NiCd battery charger.
Confined space kit	This carrying case can contain all equipment and the most commonly used accessories necessary to safely and accurately calibrate and use the Innova.
Calibration kit	A kit consisting of a carrying case containing gas cylinders, valves, and appropriate fittings to calibrate the Innova.
Data retrieval kit (Innova View)	Windows 95/98/NT compatible software necessary to access the data stored in the Innova (includes serial cable).

START UP & OPERATION

Preparing for Start Up

1. To remove the battery compartment cover, place the Innova upside down, turn the large screw counterclockwise until it is loose in its socket, then pull up.
2. Install four “D” size batteries according to the diagram inside the battery compartment. Make sure that the battery polarities are correctly oriented.



NOTE

Make sure the slide switch at the bottom of the battery compartment is set to “**ALK**” for **alkaline** or “**NI-CAD**” for **NiCd batteries**, see Chapter 6, Maintenance, Figure 6-1, Innova Battery Compartment.

3. Replace the battery compartment cover and turn the screw clockwise. Tighten snugly to compress the gasket and seal the battery compartment.



CAUTION

Some toxic gas sensors require up to 15 minutes to stabilize, after you install the batteries. If your Innova includes a toxic gas sensor(s), do not turn on and use the Innova during this period. If the unit is started up immediately after installing batteries, the “BIAS” message may appear, see Chapter 6, Maintenance, for instructions on installing or recharging batteries.

4. Verify that the hydrophobic filter and cotton ball are in good condition and installed properly in the probe body.



NOTE

For transformer versions, connect the dilution fitting directly to the disconnect coupler fitting on the front of the monitor, then connect the 10-inch probe to the dilution fitting.

5. Attach the probe to the female disconnect coupler fitting on the sample hose.
6. Attach the other end of the hose to the female disconnect coupler on the front of the instrument.



WARNING

Operation of instrument without probe/filter assembly attached will result in pump damage and possible impaired performance. Do not operate without probe/filter assembly attached.

Starting Up the Innova

Perform the following steps to start up the Innova and adjust internal circuits to fresh air readings (demand zero). Please read this entire section before turning on your Innova.



WARNING

Perform the following procedure in a “fresh air” environment (environment known to be free of combustibles and toxic gases and of normal oxygen content).

1. If you are using NiCd batteries, make sure the batteries are fully charged before you continue this procedure.
2. Press and hold the **ON/OFF** button for one second. The Innova begins the warm-up period. Several messages appear during the warm-up period, starting with the model and software version. Other screens displayed are:
 - Battery capacity on a scale from E (empty) to F (full capacity) for new alkaline or a fully charged battery pack.
 - Datalogging time left.
 - Settings for High, Warning, STEL, and TWA alarms.
 - The CAL DUE # DAYS indicates when the Innova is due for calibration according to the schedule you accepted in the user program when enabled.



NOTE

During the warm-up period the Innova determines if the toxic sensors are properly biased. If the sensors require additional biasing, the screen continuously displays “**BIAS**” with alarms instead of the gas reading. Once the readings fall within acceptable limits, a fixed time-out is initiated. During this time-out, the display will alternate between “**BIAS**” and the sensor(s) reading. If an air adjust is performed during this time-out period, it will not adjust the sensor(s) that are experiencing the ‘bias time-out’ but will adjust the other sensors.

3. When the warm-up is complete, the buzzer will beep, lights will flash several times, and display will read **“WARM UP COMPLETE”**.



NOTE

If the bump test is set to **“BUMP TST ENABLED”** the display will cue the operator to perform an **“AIR ADJUST”** and then apply gas, see Performing a Bump Test on Power-Up at the end of this chapter for instructions.

4. Hold down the **AIR** button for 3 seconds until the display counts down and the bar graph starts to scroll, then the display will read **“DONE”** once the “fresh air” reading for all active sensors is complete (20.9% for oxygen, 0 for all other sensors).



NOTE

After you **“AIR ADJUST”**, a **“XXX”** sensor failure may appear on the display screen, see Chapter 3, Alarms, Sensor Alarms, to respond to these messages.

Normal Operation

Normal operation is defined as any time after the warm-up period is complete and the Innova is not alerting you to an alarm or failure.

After warm up is complete, the Innova simultaneously displays the current gas concentration for all active sensors and the NORM icon. This display screen is defined as the normal screen. The sensor labels will alternate between the gas type and unit of measure.

During normal operation, the Innova Series gas monitor simultaneously monitors for all target gases for your configuration of the Innova.

Monitoring Gases

To monitor for the target gas(es), expose the probe to the area to be monitored. You can leave the Innova monitoring for an entire workday. The Innova monitors and displays all applicable gas conditions at the same time.



CAUTION

If your Innova includes an Ammonia (NH₃), Chlorine (Cl₂), Sulfur Dioxide (SO₂), Hydrogen Cyanide (HCN), Nitric Oxide (NO), Nitrogen Dioxide (NO₂), Phosphine (PH₃) sensor, avoid moisture accumulation. The target gas is absorbed by moisture. Inspect the probe’s hydrophobic filter and cotton ball frequently if you use the Innova in an environment where moisture might accumulate.

While in normal operation, press any button to illuminate the display screen back light.



NOTE

If the Comfort Alert is enabled, the Innova will beep and/or blink every 3 minutes to remind the operator that the unit is turned on and functioning. This feature can be disabled or enabled by the operator, see Chapter 4, Alarms, Comfort Alert, for activating/deactivating this feature.

Changing Combustible Ranges

The **RANGE** button is used to change the range of combustible gas detected. The available ranges depend on the version of the instrument, see Chapter 1, Introduction, Table 1-2. When changing to ppm range the reading is displayed in the bottom row. If toxic sensor(s) are present the combustible ppm reading will overwrite the toxic readings. If a toxic sensor(s) goes into an alarm condition, the instrument will auto range back to the next combustible range, and allow the toxic sensor(s) to be displayed.

To change the combustible gas range, press and release the **RANGE** button. The unit will beep once and switch to the alternate range (e.g. % LEL to ppm).

See Appendix C, Innova Land Surveyor, for operation of the **RANGE** button for Land Surveyor models.

If, while operating in the ppm range, the gas concentration exceeds the full scale range, the Innova will automatically switch to the % LEL (or % VOL if so configured) range.

Turning Off the Innova

Press and hold the **ON/OFF** button for 3 seconds. A power off message on the display screen counts down from 3 seconds. The Innova sounds a pulsing tone, and the backlight automatically turns on during the power off sequence.

To cancel the power off command, release the **ON/OFF** button before the display screen goes blank.



NOTE

The STEL, TWA, maximum, and minimum (for O₂) readings are automatically reset on power down unless the Lunch Break mode is enabled, see Chapter 4, User Program, Lunch Break Option for more detail.



CAUTION

If the Innova will not be used for more than 4 weeks, remove the batteries from the instrument. Failure to remove the batteries prior to storage could result in damage to the instrument.

If your Innova uses rechargeable NiCd batteries, the batteries must be fully charged before each use. When using alkaline batteries, it is best to install fresh batteries before each use, see Chapter 6, Maintenance, to recharge NiCd batteries or replace alkaline batteries.

Performing a Bump Test on Power-Up

When the bump test option is set to **“BUMP TST ENABLED”** the display alerts the operator to perform a bump test after the warm-up cycle is complete, see Chapter 4, User Program, Bump Test on Power-Up Option.

To perform the bump test:

1. Assemble the calibration kit, see Chapter 5, Calibration.
2. Turn on the Innova and wait for it to complete the warm-up cycle. The display will read **“AIR ADJUST NOW”**. The screen will blink on and off with alternating lights, prompting the operator to perform a fresh air adjust.
3. Press and hold the **AIR** button for three seconds until **“DONE”** appears. Once the Innova has been air adjusted, the display will begin counting down, and prompt the operator to **“APPLY GAS”**, alternating with **“BUMP TEST”**. An audible beep will sound.



NOTE

If an air adjust is not performed within 30 seconds, a **“BUMP TEST INCOMPLETE”** message appears and the buzzer beeps on and off for three seconds. The Innova will return to the normal operating mode.

4. Attach the tubing from the regulator to the probe tube, the Innova will draw gas from the cylinder.
5. The Innova should respond to the detected gas and beep to indicate that a Bump Test is being performed. All gas levels for standard gases are displayed as in the normal operating mode.



NOTE

If no gas is detected during the **“APPLY GAS”** countdown, a **“BUMP TEST INCOMPLETE”** message appears and the buzzer beeps on and off for 3 seconds. The Innova will return to normal operating mode.

Once gas is detected a countdown is initiated. During this single beep countdown the user should visually verify the sensors are responding correctly.



NOTE

Bump test peak readings are recorded. Events are recorded as **“BUMP TEST COMPLETE”** if the Innova detected gas, and **“BUMP TEST ABORTED”** if the Innova did not detect gas.

A **“BUMP TEST COMPLETE”** message will be displayed. Then the screen will alternate between **“REMOVE GAS”** and the gas readings.

6. Remove the tubing from the probe.

Once the instrument detects that the gas has been removed the screen display an **“ALARMS SILENCED”** message. The alarms will be silenced for a blind 30 second count.

After the 30 second count has elapsed an **“ALARMS ACTIVE”** message will display briefly, audible alarms will be enabled and the Innova will return to the normal operating mode.



NOTE

If the Innova does not respond properly during the bump test, follow the instructions in Chapter 5, Calibration, or Chapter 6, Troubleshooting sections of this manual.



NOTE

For instruments having a toxic sensor other than CO or H₂S, calibration gases are only available in single-gas cylinders. Therefore a multi-step bump process has been programmed into the bump test routine. First, the standard sensors are bumped using a multi-gas mixture. Then the first Toxic sensor is bumped using a single-gas cylinder and repeated if your unit has a second toxic sensor.



WARNING

Avoid using a gas mixture containing H₂S for bump testing an instrument with Cl₂, NH₃, NO₂ or PH₃ sensors.

ALARMS

This chapter describes Innova alarm indications, display messages, and response for the following types of alarms:

- Gas Alarms
- Battery Alarms
- Sensor Alarms
- Pump Alarms
- Datalog Alarms
- Temperature Alarms

Gas Alarms

This section describes alarm indications, display messages, and response to Low, High, STEL, and TWA gas alarms. The backlight automatically turns on during all gas alarms.

Gas Alarm Indications

Table 3-1 lists the indications for each type of gas alarm.

Table 3-1 Alarm Indications (Gas Alarms)

Alarm	Display	Light/Buzzer
Low Gas Alarm	Reading flashes	slow flashing/pulsing (once/second)
High Gas Alarm	Reading flashes	fast flashing/pulsing (twice/second)
Decreasing O ₂ Alarm	Reading flashes	fast flashing/pulsing
Increasing O ₂ Alarm	Reading flashes	fast flashing/pulsing
STEL Gas Alarm	STEL icon	flashing/pulsing
TWA Gas Alarm	TWA icon	flashing/pulsing

Responding to Gas Alarms

1. Follow the established procedure for the type of gas alarm (Low, High, STEL or TWA). If a procedure is not in place, establish one that is appropriate for your application.
2. Reset the alarm circuit. The Innova resets the circuit according to the alarm reset setting “**AUTO RESET**” or “**MANUAL RESET**”, see Chapter 4, User Program, Alarm Latch option to enter the program and display and/or update the setting.
 - If the alarm reset setting is **auto reset**, the Innova resets the applicable alarm circuit after the gas reading falls below the alarm setting (or rises above for decreasing O₂).
 - If the alarm reset setting is **manual reset**, press the → **ON/OFF** button to reset the alarm circuits after the gas reading falls below the alarm setting (or rises above for decreasing O₂).

Battery Alarms

This section describes alarm indications, display messages, and response for the following battery alarms: Low Battery and Replace Battery. The backlight automatically turns on during all battery alarms

Battery Alarm Indications.

Table 3-2 Alarm Indications (Battery Alarms)

Alarm	Display	Light/Buzzer
Low Battery	LOW BATTERY	double flash/beep (every two minutes) battery icon flashes
Battery Failure (ALK)	REPLACE BATTERY	constant flash/beep battery icon steady
Battery Failure (NiCd)	RECHARGE BATTERY	constant flash/beep battery icon steady

Responding to Battery Alarms

This section describes response to Low Battery and Replace/Recharge Battery alarms.

1. For low battery alarm, proceed to step 2 as soon as possible. The Innova will continue to function properly for approximately 1/2 hour until the Replace/Recharge Battery screen and alarm sounds. For battery failure alarm, turn off the Innova immediately. It is not functioning as a gas detection device.

2. You must replace the alkaline or recharge the NiCd batteries within your monitor before putting it back into operation, see Chapter 6, Maintenance, for procedures to replace or recharge your batteries.

**WARNING**

Always replace or recharge batteries in a “fresh air” environment (environment known to be free of combustible and toxic gases and of normal oxygen content).

Sensor Alarms

This section describes alarm indications, display messages, and response to sensor failure alarms. The backlight automatically turns on during all failure alarms.

Sensor Alarm Indications

Table 3-3 lists the indications for each type of failure alarm.

Table 3-3 Alarm Indications (Failure Alarms)

Alarm	Display	Light/Buzzer
Sensor Failure	XXX	Continuous

Responding to Sensor Alarms

A sensor failure alarm can occur during normal operation or calibration. Alarms that occur during calibration are described in Chapter 5, Calibration.

1. Examine the display screen to determine which sensor is failing. The failing sensor displays “**XXX**” instead of the gas reading for a sensor that has failed an air adjust, Calibration, or gas missing sensor.
2. Perform an air adjust, if the sensor(s) continues to fail, perform a calibration, see Chapter 5, Calibration.
3. If the sensor(s) continue to fail, replace the sensor(s), see Chapter 6, Replacing Sensors.
4. You can enter the Innova user program and change the sensor status setting to “**OFF**”. All information for an absent sensor is removed from the normal screen and recorded as XXX in the datalog.

**WARNING**

The Innova does not display gas readings, initiate alarms, compute averages, or store data for “OFF” sensor(s).

Pump Alarm

This section describes alarm indications, display messages, and response to sensor, memory, and pump failure alarms. The backlight automatically turns on during all failure alarms.

Pump Alarm Indications

Table 3-4 lists the indications for each type of failure alarm.

Table 3-4 Alarm Indications (Failure Alarms)

Alarm	Display	Light/Buzzer
Pump Failure	PUMP FAILED alternating with PRESS→ TO CLEAR alternating with gas readings. X in place of spinning icon	alternating/beeping (every second)

Responding to a Pump Alarm

1. Check the hose, probe, and filter for debris.
2. Press the → **ON/OFF** button to reset the alarm circuit and return to the normal screen with the pump icon spinning.
3. If the pump restarts, and the monitor functions normally, the problem was momentary. If the indications remain, turn the monitor off, then investigate the probe, hose, or internal flow system for obstructions, dirty filter, or loose sensor(s) inside instrument.



WARNING

Operation of instrument without probe/filter assembly attached will result in pump damage and possible impaired performance. Do not operate without probe/filter assembly attached.

Datalog Alarm

This section describes the alarm indication, display message, and response for the datalog full alarm. A datalog full alarm occurs when the datalog becomes full and the datalog full command was accepted as **“STOP ON FULL”**.

Datalog Alarm Indications

Table 3-5 lists the indications for the datalog full alarm.

Table 3-5 Alarm Indications (Datalog Full Alarm)

Alarm	Display	Light/Buzzer
Datalog Full	LOGGING STOPPED	flashing/pulsing (every 30 seconds)

Responding to the Datalog Alarm

Perform one of the following procedures to reset the datalog alarm.

- Download the data, save and clear the log when prompted.
- Enter the Datalog Features Menu, and update the datalog full command to **“OVRWRITE ON FULL”**, see Chapter 4, User Program, Log Memory Manager option.
- Enter the Datalog Features Menu and clear the datalog, see Chapter 4, User Program, Clear Log Memory.

Temperature Alarm

The Innova has an alarm to alert the user that the unit is being operated at a temperature that exceeds its operating specification of -20°C to +45°C (-4°F to +113°F). If the temperature is outside this range, the following message appears every 30 seconds and the sensor readings may be inaccurate: **“TEMP WARNING”** alternating with the gas readings.

The buzzer beeps and lights flash twice every 30 seconds, and the condition will clear automatically when the temperature returns to within the operating limits.



NOTE

The temperature alarm is user enabled or disabled, with the default setting **“disabled”**, see Chapter 4, User Program, Temperature Alarm.

USER PROGRAM

This chapter includes an introduction to the Innova User Program and step-by-step procedures to run the program.

About the User Program

The Innova User Program allows you to view and update factory-set parameters and display several items, such as the battery voltage, datalog status, current temperature, time, and date.

The menu-driven program has three main menus:

- Display Menu
- Advanced Features Menu
- Datalog Features Menu

The user navigates through the user program by using the three buttons:

→ **ON/OFF**

↑ **AIR**

↓ **RANGE.**

- The right arrow (→) is used to **accept** within the menu.
- The up arrow (↑) and down arrow (↓) are used to **scroll** either forward or backwards through the menus.



NOTE

The Innova has a time-out feature. If no buttons are pressed for 10 seconds while in the Display Menu, Advanced Features Menu or Datalog Features Menu the display will flash and buzzer will beep for 10 seconds. If no buttons are pressed during this time, the Innova will return to the normal operating mode.

Display Menu

In the Display Menu the following may be viewed:

- Battery Capacity
- Peak Readings (Option to Clear)
- STEL Levels (Toxic Sensors Only)
- TWA Levels (Toxic Sensors Only)
- Temperature
- Date and Time
- Operator ID (Option to Change)
- Location ID (Option to Change)
- Exit

To enter the Display Menu:

1. Press and hold the ↓ **RANGE** button for 3 seconds. The display will show “**DISPLAY MENU**” and count down from 3 seconds. Your first screen will display the “**BATTERY CAPACITY**”.
2. To scroll to the next screen, use the ↑ button. To scroll backwards through the menu, press the ↓ button. Continue to scroll through the screens to display the desired information, clear Peak Readings, or change an Operator or User ID.
3. To exit the program, press either ↑ or ↓ until you get to the ‘**EXIT**’ display, then press → to exit to the normal operating mode.



NOTE

When Peak values are displayed, after 3 seconds the display reads “**PRESS → TO CLEAR**”, so the user can clear peak values if desired.

To change a User or Operator ID:



NOTE

Operator and Location must first be entered before a selection can be made, see Edit Operator, Location, and Instrument ID's Chapters.

1. For the Operator ID and Location ID screens, to change the selection press the → button, and then use ↑ or ↓ to designate a new selection.
2. Press the → button to accept the selected ID.

Accessing Password-Protected Menus

A password may be used to add extra security to the following menus:

- Advanced Features protected by “PASSWORD”
- Datalogging Menu protected by “LOGWORD”
- Calibration Menu protected by “CALWORD”

See Create/Edit CalWord/PassWord/LogWord for details on creating a password. If enabled, a code must be entered before the user may enter these menus.

To enter a PassWord, LogWord, or CalWord:

1. Press and hold \uparrow and \downarrow for 3 seconds. The message “**FEATURES MENU**” appears on the display and counts down from 3 seconds, and then displays “**BEGIN CAL**”. Press \downarrow to scroll to “**ADVANCED FEATURES**” or “**DATALOG MENU**”.
2. Stop scrolling at the desired screen and press \rightarrow to accept. The display now reads “**PASSWORD**”, “**LOGWORD**”, or “**CALWORD**” and “* * *” (if protection has been enabled). The cursor is on the first asterisk.



NOTE

If the “***” does not appear when entering any of the three menus, security protection is not enabled.

3. Press \uparrow or \downarrow to scroll to the correct character.
4. Press \rightarrow to accept. The cursor moves to the next character.
5. Repeat steps 4 and 5 until all three characters are accepted. If your entry is correct, you will advance to the next screen. If your entry is incorrect, you will return to the original screen. Begin at step 2 to re-enter your password.

Advanced Features Menu

The Advanced Features Menu allows you to change the following parameters of the instrument.

The menu is as follows:

- Edit Alarms
- O2 Alarm Configuration
- Alarm Latch Option
- Lunch Break Option
- Backlight Delay Selection
- Calibration Interval Selection
- Bump Test Option
- Sensor Select
- Setting Auto Cal Gas Values
- Comfort Alert Options
- Temperature Alarm
- Change Cal Word
- Change Password
- Change Logword
- Exit

To enter the Advanced Features Menu:

1. Press and hold both the \uparrow **AIR** and \downarrow **RANGE** buttons for 3 seconds. The screen displays “**FEATURES MENU**” and counts down from 3 seconds.
2. The first screen displayed after the countdown is “**BEGIN CAL**”. Press the \downarrow button, then press the \rightarrow button. If prompted by “**PASSWORD**” and “***”, enter a password as described in the previous section, Accessing Password-Protected menus. When entered correctly, or if PassWord is not enabled, you are now at the first option “**EDIT ALARMS**” in the Advanced Features Menu.



NOTE

The Innova has a time-out feature. While in the Advanced Features Menu, if a button is not pressed within 10 seconds the display will flash and the buzzer will beep for 10 seconds. If no button is pressed during the 10 seconds, the Innova will return to normal operating mode.

EDIT ALARMS

This allows the user to increase or decrease the High and Low Alarms for each gas. See Chapter 1, Introduction, Table 1-2, Sensor Specifications for factory default settings.

1. Press → to enter the HC screen. The high alarm reading will flash.
2. Press ↑ or ↓ to increase or decrease the alarm setting. If you choose to keep the alarm as is, press → to move to the next alarm setting.
3. Continue step 2 until you have set all gas alarms. After the last gas alarm is set, the display automatically returns to the “**EDIT ALARMS**” screen.



NOTE

You will scroll through the following gas alarms, appropriate to your version of Innova: HC, O₂, TOXIC1, TOXIC2.

4. Press ↑ or ↓ to continue scrolling through the Advanced Features Menu.

O₂ ALARM CONFIGURATION

This option allows you to set the oxygen alarms (High and Low) to either increasing or decreasing.

Options you can choose are:

- **ONE INC/ONE DEC** - The warning alarm is set to decreasing at 19.5% VOL and high alarm increasing at 23.5% VOL.
- **TWO ALARM/DECREASE** - Both alarms are set to decrease. Warn at 19.5% VOL and High at 18.0% VOL.
- **TWO ALARM/INCREASE** - Both alarms are set to increase. Warn at 22.5% VOL and high at 23.5% VOL.

The factory default setting is “**ONE INC/ONE DEC**”.

To enter this menu from the Advanced Features Menu:

1. Press → to accept “**O₂ ALARM CONFIG**”.
2. Press ↓ or ↑ to scroll through the settings. Press the → to accept the setting.
3. Press ↓ to continue scrolling through the Advanced Features Menu.

ALARM LATCH OPTION

This option changes the alarm setting to either “**AUTO RESET**” for automatically resting the alarm or “**MAUNAL RESET**”, in which case an alarm must be manually reset. The factory default setting is “**AUTO RESET**”.

1. Press → to accept “**ALARM LATCH**”.
2. Press ↓ or ↑ to scroll between settings. Press → to accept the setting.
3. Press ↓ to continue scrolling through the Advanced Features Menu.

LUNCH BREAK OPTION

The lunch break option allows the user to either reset averages (STEL and TWA) or retains averages when the Innova is turned off. The factory default setting is “**RESET AVERAGES**”.



NOTE

If the lunchbreak menu is set to “**RETAIN AVERAGES**”, the Innova will retain the STEL and TWA averages when turned off. If the lunchbreak menu is set to “**RESET AVERAGES**”, the Innova will reset the averages when turned off.

To change the lunch break menu from the Advanced Features Menu:

1. Press → at the screen “**LUNCH BREAK**”.
2. Press ↓ or ↑ to scroll through the settings. Press → to accept the setting.
3. Then press ↓ to continue scrolling through the Advanced Features Menu.

BACKLIGHT DELAY SELECTION

The backlight delay feature sets the number of seconds the backlight is illuminated after any button is pressed. The factory default is setting is 5 seconds. Your options are in 5 second increments up to 60 seconds, and 2, 3, 5, or 10 minutes.

To change the backlight delay setting from the Advanced Features Menu:

1. Press → at the screen “**BKLIGHT DELAY**”.
2. Press ↓ or ↑ to scroll through the settings. Press → to accept the setting.
3. Then press ↓ to continue scrolling through the Advanced Features Menu.

CAL INTERVAL SELECTION

This sets the number of days between calibrations.



NOTE

The number of days left until calibration is displayed during the warm-up cycle. When the Innova is due for calibration, display reads “**CAL OVERDUE**” and buzzer and lights, pulse and flash after the warm-up cycle is complete.

Your options are no cal reminder, 1 to 6 one-day increments and 1 to 26 one-week increments. The factory default setting is “**NO CAL REMINDER**”, which means the calibration reminder function is turned off.



NOTE

For **optimum** performance, calibrate the Innova before every use.

To change the calibration reminder setting from the Advanced Features Menu:

1. Press → at the screen “**CAL INTERVAL**”.
2. Press ↓ or ↑ to scroll through the settings.
3. Press → to accept the setting.
4. Then press ↓ to continue scrolling through the Advanced Features Menu.

BUMP TEST ON POWER-UP OPTION

The bump test option enables or disables the Innova to cue the user to apply gas for a bump test immediately after the Innova warm-up cycle is complete. The factory default setting is “**BUMP TST DISABLED**”. A bump test is sometimes necessary, to ensure the Innova is detecting gases before each use.

To change the bump test setting from the Advanced Features Menu:

1. Press → at the screen “**BUMP TEST**”.
2. Press ↓ or ↑ to scroll between “**BUMP TST DISABLED**” to “**BUMP TST ENABLED**”.
3. Press → to accept the setting.
4. Then press ↓ to continue scrolling through the Advanced Features Menu.

SENSOR SELECT

The sensor select function turns the HC and O2 sensor(s) on or off. Both toxic 1 and toxic 2 sensor(s) may be turned off or changed to monitor another gas type provided the corresponding sensor(s) are installed in the proper location.



WARNING

The Innova does not display gas readings, initiate alarms, compute averages, or store data for “OFF” sensor(s).

To change the sensor select setting from the Advanced Features Menu:

1. Press → at the screen “**SENSOR SELECT**”. All four gases and their settings will display. The cursor and reading will flash for HC.
2. Press ↑ or ↓ to change the setting to “**ON**” or “**OFF**”. If you choose to keep the setting, as is, press → to move on to the O2.
3. Repeat step 2 for O2, press → to move on to the Toxic 1 sensor.
4. For the toxic sensors press ↑ or ↓ to select or change the sensor type, press → to move on to Toxic 2.
5. Continue step 4 for Toxic 2.
6. Press ↓ to continue scrolling through the Advanced Featuring Menu.



NOTE

You will scroll through the following sensor selections, appropriate to your version of Innova: HC, O2, Toxic 1, Toxic 2.

SETTING AUTOCAL GAS VALUES

This function allows you to set the auto calibration values to the concentration of the cylinders you are using.



NOTE

The factory default settings for a standard four gas instrument are HC 50%LEL, O2 12.0% VOL, H2S 25 PPM, and CO 50 PPM. These are the values that match **Thermo** GasTech’s multi-gas cylinders.

To change the value(s) from the Advanced Features Menu:

1. Press → at the screen “**AUTOCAL GAS VAL**”. All four gases and their values will display. The cursor and reading will flash for HC (if installed and ON).
2. Press ↑ or ↓ to change value up or down.
3. Once you’ve reached the desired value, press → to move on to the HC ppm. If you choose to keep the setting, as is, press → to move on to the next sensor.

4. Continue this process through all gases.



NOTE

You will scroll through the following autocal gas values, appropriate to your version of Innova: HC, O2, TOXIC1, TOXIC2.

COMFORT ALERT OPTIONS

The comfort alert is a friendly reminder that the instrument is on. The reminder begins 3 minutes after the last button press and will sound every 3 minutes while in the normal operating mode. The alert has four options:

- Beep Only - Every 3 minutes the buzzer sounds.
- Blink Only - Every 3 minutes the lights flash.
- Blink and Beep- Both buzzer beeps and lights flash every 3 minutes.
- Both Off - Option disabled.

The factory default setting is **“BLINK AND BEEP”**.



NOTE

The 3 minute comfort alert timer is reset after any button is pressed by the user.

To change the setting from the Advanced Features Menu:

1. Press → at the screen **“COMFORT ALERT”**.
2. Press ↓ or ↑ to scroll through the options.
3. Press → to accept the setting. Press ↓ to continue scrolling through the Advanced Features Menu.

TEMPERATURE ALARM

The Innova has an alarm to alerts the user that the Innova is being operated at a temperature that exceeds its operation specification of -4°F to 113°F (20°C to 45°C). When the temperature alarm is activated, the buzzer and lights alternate every 30 seconds. The factory default setting is **“TEMP ALR DISABLED”**.

To change the setting from the Advanced Features Menu:

1. Press → at the screen **“TEMP ALARM”**.
2. Press ↓ or ↑ to change to either **“TEMP ALR DISABLED”** or **“TEMP ALR ENABLED”**.
3. Press → to accept the setting.
4. Press ↓ to continue scrolling through the Advanced Features Menu.

ENTER/EDIT CALWORD, PASSWORD, OR LOGWORD

These options add extra security to the calibration process (CALWORD), Advanced Features Menu (PASSWORD), and Datalog Features Menu (LOGWORD). By changing the default factory setting of “****”, you automatically turn this option on, and password protect that area of the user program. If turned on, a code must be entered before one may continue a process. If “****” is entered, the password security is turned off. The factory default setting for each password is “****”, or disabled.

To add or change the code from the Advanced Features Menu,

1. Press → at the appropriate screen “**CHANGE CALWORD**”, “**CHANGE PASSWORD**” or “**CHANGE LOGWORD**”. The screen will display either three asterisks “****”, or the three digit code, with the cursor on the first character.
2. Press ↓ or ↑ to change the first character of the code. You have the option of “*, 0 through 9”.



NOTE

When entering a CalWord, PassWord, or LogWord all three characters must be a number, 0 through 9. A password containing one or more “*” is not valid, no security protection is implemented if a password contains an “*”.

3. Press → to accept the setting, and move on to the second character. If you do not want to change the first character, press → to move on to the second character.
4. Repeat the process through the third character.
5. Press ↓ to continue scrolling through the Advanced Features Menu.

EXIT

The ‘**EXIT**’ screen exits you from the Advanced Features Menu. Press → at “**EXIT**” to return to the normal operating mode.

Datalog Features Menu

The Datalog Features Menu allows you to change the following parameters of the instrument.

The menu is as follows:

- Adjust Date and Time
- Edit Operator IDs
- Edit Location IDs
- Edit Instrument ID
- Log Memory Manager Option
- Log Averages Selection
- Log Interval Selection
- View Log Status
- Clear Log Memory
- View Log Began
- Exit

To enter the Datalog Features Menu:

1. Press and hold both the \uparrow **AIR** and \downarrow **RANGE** buttons for 3 seconds. The screen displays “**FEATURES MENU**” and counts down from 3 seconds.
2. The first screen displayed after the countdown is “**BEGIN CAL**”. Press the \downarrow button twice. The display will read “**DATALOG MENU**”.
3. Press the \rightarrow button. If prompted by “**LOGWORD**” and “****”, enter a LogWord as described earlier in this chapter. When entered correctly, or if LogWord is not enabled, you are now at the first option “**ADJUST DATE AND TIME**”.



NOTE

The Innova has a time-out feature. While in the Advanced Features Menu, if a button is not pressed within 10 seconds the display will flash and the buzzer will beep for 10 seconds. If no button is pressed during the 10 seconds, the Innova will return to normal operating mode.

ADJUST DATE AND TIME

The date and time are adjustable by the user. The default factory settings are Pacific Standard Time. The innova uses a 24-hour format to display time. For example, 21:30:00 is 9:30 PM.

To change the date and time from the Datalog Menu:

1. Press → at the screen “**ADJ DATE AND TIME**”. The date and time will appear, with the cursor on the month that is flashing.
2. Press ↑ or ↓ to change to the correct month. Once you’ve reached the correct value, press → to move to the day of the month. If you choose to keep the setting, as is, press → to move to the year.
3. Continue this process through remaining date and time settings. Once you’ve completed and pressed → past the seconds, the “**ADJ DATE AND TIME**” screen displays, and your selection has been accepted.

EDIT OPERATOR, LOCATION, AND INSTRUMENT IDS

The IDs are used to allow the user to identify the Operator and Location of personnel operating the Innova. The information is stored in the datalogging memory for retrieval at a later time. The Innova has three IDs the user can update:

- The **Operator ID** screen allows the Innova to reference logged data with 16 different operator codes.
- The **Location ID** screen allows the Innova to reference logged data with 64 different location codes.
- The **Instrument ID** screen allows you to uniquely identify the Innova.

The Operator and location IDs are a two row, 8 characters per row, field. Each character accepts A-Z, a-z, 0-9, asterisk (*), and blank space. The Innova User Program stores up to 16 Operator and 64 Location IDs.

Each Operator ID is uniquely referenced by a number from 1 to 16. Each Location ID is referenced by a number from 1 to 64. You can accept (and record in the datalog) an Operator and/or Location ID by its reference number.

To add or change the Operator and Location ID from the Datalog Menu:



NOTE

The factory default setting for Operator, Location, and Instrument IDs are blank.

1. Press → at the appropriate screen **“EDIT OPER ID”, “EDIT LOC ID”, or “INST ID”**. The first ID screen will appear, you can change this screen by pressing → to accept and start editing this ID or you can press ↑ or ↓ to scroll through the other ID screens. Then press → to accept.
2. Press ↓ or ↑ to change the first character of the ID. You have the option of **“*, 0 - 9, A-Z, a-z, and blank”**.
3. Press → to accept the character or space, and move to the next character. If you do not want to change the first character, press → to move to the next character.
4. Repeat the process through both rows of characters.
5. Press ↓ to continue scrolling through the Datalog Menu.



NOTE

For the Operator ID and Location ID screens, the ID's reference number is displayed on the bottom line. Press the ↑ button to continue scrolling through the various operators and locations you want to display or update. Then press → to edit or update the screen.

LOG MEMORY MANAGER

This instructs the datalog memory to either overwrite the oldest data, **“OVRWRITE ON FULL”**, or stop recording data, **“STOP ON FULL”**, when the memory is full. The factory default setting is **“OVRWRITE ON FULL”**.



NOTE

If you accept **“STOP ON FULL”**, the Innova alerts you with a datalog full alarm when the Innova is no longer recording data, see Chapter 3, Alarms. If you accept **“OVRWRITE ON FULL”**, the Innova begins writing over the oldest data when the datalog is full. The overwritten data is not retrievable.

To change the setting, from the Datalog Features Menu:

1. Press → at the screen **“LOG MEM MANAGER”**.
2. Then press ↑ or ↓ to display the correct setting.
3. Press → to accept the setting.
4. Then press → to continue scrolling the Datalog Features Menu.

LOG AVERAGES

This parameter controls which averages (STEL or TWA) the Innova stores in the datalog. Available selections for each toxic sensor that is active are:

- LOG ALL - Log both STEL and TWA
- LOG TWA ONLY - Log TWA only
- LOG STEL ONLY - Log STEL only
- NO AVE LOGGING - Neither STEL or TWA are logged

The factory default setting is **“LOG ALL”**.

To change the setting for logging STEL and TWA from the Datalog Features Menu:

1. Press → at the screen **“LOG AVERAGES”**.
2. Press ↓ or ↑ to scroll between options until you get to the appropriate screen.
3. Press → to accept the setting.
4. Press ↓ to continue scrolling through the Datalog Features Menu.

LOG INTERVAL

This parameter instructs the Innova how often to record data in the datalog. You have the option of 5, 15, 30, 60, 90, 300, or 900 seconds. The factory default setting is **“LOG EVRY 60 SEC”**.

To change the setting for log interval from the Datalog Features Menu:

1. Press → at the screen **“LOG INTERVAL”**.
2. Press ↓ or ↑ to scroll between options until you get to the appropriate screen.
3. Press → to accept the setting.
4. Press ↓ to continue scrolling through the Datalog Features Menu.

Table 4-1 illustrates approximately how long it takes to fill the datalog for the various datalog interval settings.

**Table 4-1 Datalog Capacity Specifications
(accumulated on time)**

Sample Interval	Capacity (No Alarm Activity)
5 seconds	18 hours
15 seconds	55 hours
30 seconds	111 hours
60 seconds	9 days
90 seconds	13 days
300 seconds	36 days
900 seconds	108 days

LOG STATUS

This is a display screen only, which indicates the number of datalog hours or days left in memory that is not currently occupied.

To display the number of hours or days left, from the Datalog Features Menu:

1. Press → at the screen **“LOG STATUS”**. The screen displays reads **“XX LOG HRS LEFT”** or **“XX LOG DAYS LEFT”** (“XX” for number of hours or days available in memory). The display will automatically go back to the **“LOG STATUS”** screen.
2. Press ↑ or ↓ to continue scrolling the Datalog Features Menu.

CLEAR LOG

To clear the data in the memory, from the Datalog Features Menu:

1. Press → at the screen **“CLEAR LOG”**. The screen displays **“↑ AND ↓ TO CLEAR”**.
2. Press and hold ↑ and ↓ for 3 seconds and release. The display reads **“CLEARING LOG”** and beeps for several seconds. When complete the display indicates **“LOG CLEARED”**.



NOTE

If you do not want to clear the log, press the → button and continue scrolling through the Datalog Features Menu.



CAUTION

You cannot recover data after you clear the log. Download all required data before you clear the log.

LOG BEGAN

This screen displays the date and time when the log was last cleared.

To display this data and time, from the Datalog Features Menu:

1. Press → at the screen **“LOG BEGAN”**. The screen displays the data and time. For example, **“7/12/99 10:00:00”**. The display automatically goes back to the **“LOG BEGAN”** screen.
2. Press ↑ or ↓ to continue scrolling on the Datalog Features Menu.

EXIT

The ‘EXIT’ screen exits you from the Datalog Features Menu. Press → to exit the menu and return to the normal operating mode.

CALIBRATION

This chapter contains instructions to prepare the calibration kit and calibrate the Innova Series gas monitor. For Land Surveyor, Transformer Gas Tester, Soil and Fuel Vapor, see Appendix C for supplemental instructions.



WARNING

Accurate calibration of the Innova Series gas monitor is essential to ensure correct readings of gas and oxygen concentrations. Incorrect or improper calibration can impair the performance of the instrument and place you in potential danger if hazardous conditions exist.

Preparing the Calibration Kit

Perform the following steps to prepare the Innova calibration kit.



WARNING

LEL response will vary for different gases. For best accuracy, LEL calibration should be done using the target gas of the LEL/ppm sensor. (Expected relative combustible responses, listed in Appendix B, Interference Factors, are not verified by UL.)

1. Verify that the calibrating area contains a level surface to set the Innova and calibration kit accessories upon.
2. Turn on the Innova instrument. Enter the Display Menu and verify that the Battery Capacity screen displays at least three bars (see “Display Menu” at the beginning of Chapter 4, User Program for a detailed description).
3. Carefully screw the threaded end of the regulator into the gas cylinder.
4. Attach the sample tubing over the fitting on the regulator.

Calibrating the Innova

The Innova offers two calibration options, automatic and manual.

- The **automatic calibration (AUTO CAL)** displays all active sensors on the display screen at the same time. You can calibrate all active sensors simultaneously using a multi-gas cylinder available from **Thermo GasTech**. The concentrations set in the Auto Cal Gas Value screen must match the multi-gas mixture, see Chapter 4, User Program, Setting Auto Cal Gas Values.
- During the **manual calibration (MAN CAL)** only one active sensor is displayed on the screen at a time, only one sensor is calibrated during a manual calibration. It is recommended to use a single gas cylinder for manual calibrations. During a manual calibration you may manually change the concentration of the gas before the gas is applied. The default value is that set in the Auto Cal Gas Values screen, see Chapter 4, User Program, Setting Auto Cal Gas Values.

Auto Calibration



WARNING

Calibrate the Innova in a “fresh air” environment (environment known to be free of combustibles and toxic gases and of normal oxygen content).



NOTE

If you use the automatic adjustment method to calibrate the sensor, make sure the gas cylinder contains the same concentrations of the target gas as the values set in the “**AUTOCAL GAS VAL**” menu, see Chapter 4, User Program, Setting Auto Cal Gas Values.

1. Hold down the **AIR** button for 3 seconds until the display counts down and the bar graph starts to scroll, then the display will read “**DONE**” once the “fresh air” reading for all active sensors is complete (20.9% for oxygen, 0 for all other sensors).



NOTE

After you complete the fresh air adjustment, a “**XXX**” may appear on the display screen in place of a sensor reading. The buzzer and lights will be on steady, see Calibration Alarms section at the end of this chapter to respond to this message.

2. Press and hold \uparrow and \downarrow for 3 seconds. The message **“FEATURES MENU”** appears on the display and counts down from 3 seconds, and then displays **“BEGIN CAL”**.
3. Press \rightarrow to accept and begin a calibration. If a CalWord has not enabled, the **“AUTO CAL”** screen is displayed. Skip the next section and proceed with Calibrating with the Auto Calibration (cont.).

**NOTE**

If prompted by **“CALWORD”** and **“****”**, enter a password as described in the next section.

Entering a CalWord

A password may be used to add extra security to the Calibration with a **“CALWORD”**, see Chapter 4, User Program, Create/Edit CalWord/PassWord/LogWord. If turned on, a code must be entered before the user may perform a calibration.

To enter a CalWord (if activated):

1. Press and hold \uparrow and \downarrow for 3 seconds. The message **“FEATURES MENU”** appears on the display and counts down from 3 seconds, and then displays **“BEGIN CAL”**.
2. Press \rightarrow to accept. The display reads **“CAL WORD”** and **“* * *”**. The cursor is on the first asterisk.
3. Press \uparrow or \downarrow to scroll to the correct character.
4. Press \rightarrow to accept. The cursor moves to the next character.
5. Repeat steps 3 and 4 until all three characters are accepted. If correct, the next display reads **“AUTOCAL”**. If the CalWord is incorrect, the display reads **“BEGIN CAL”** message. Begin at step 2 to start over.

Auto Calibration (cont.)

4. Press \rightarrow to accept **“AUTO CAL”**. The screen displays **“BEGIN AUTOCAL”** alternating with **“APPLY GAS”** counting down from 30 seconds. If no gas is detected during this period, the screen returns to **“BEGIN CAL”**.
5. Attach the tubing from the regulator to the probe tube, the Innova will draw gas from the gas cylinder.
First, the display will read **“CAL IN PROCESS”**. Then the screen displays **“CAL TIME LEFT”** (counting down from 75 seconds) alternating with the gas readings.



NOTE

During calibration, datalogging is disabled but calibration events are recorded in the log.

6. When calibration is complete, the display reads **"AUTO CAL PASSED"** and then alternates between **">ACCEPT, ABORT"** and the gas readings. The gas labels alternate with **"PASS"**. Press → to accept. The display will show **"CAL ACCEPTED"**, and then alternate between **"REMOVE GAS"** and the gas readings.

If you choose to abort, press ↓ to scroll to **"ABORT"** then → to accept the abort option.

The display will read **"CAL ABORTED"** and then alternate between **"REMOVE GAS"** and the gas readings.



NOTE

A **"WEAK"** or **"FAIL"** flag may appear in place of the **"PASS"** flag in the case of a weak or failed sensor. See the instructions in the Calibration Alarms section, later in this chapter for corrective action.

7. Remove the tubing from the probe. After fresh air has been detected, the display will alternate between **"ALARMS SILENCED"**, and the readings, and then return to the normal operating mode, after an **"ALARMS ACTIVE"** message is displayed.
8. Unscrew the regulator from the cylinder, leave the components of the calibration kit assembled for convenience and place in the storage case.

Calibration of Toxic Gases other than H₂S & CO or for 0-100% Vol TC Sensor

These calibration gases are only available in single-gas cylinders. Therefore a multi-step calibration process has been programmed into the Auto Calibration routine. First, the standard sensors are calibrated using a multi-gas mixture. Then the first sensor is calibrated using a single-gas cylinder, and repeated if your unit has a second sensor.

1. Begin the calibration process by performing an Auto Calibration. The non-standard sensor(s) will be ignored during the multi-gas calibration.

2. When the multi-gas Auto Calibration is complete, a double beep prompts the user to begin the non-standard sensor calibration(s). The default gas concentration is displayed with the ADJ icon. Change the concentration if the gas cylinder does not match the concentration displayed.
3. Once the concentrations match, Press → to begin the calibration.
4. Apply the calibration gas and follow the prompts to complete the calibration process. When the first non-standard sensor is complete, and a second non-standard sensor is present, a double beep prompts the user to begin the second sensor calibration. Repeat steps 2, 3 and 4.



WARNING

Avoid using a gas mixture containing H_2S for calibrating an instrument with Cl_2 , NH_3 , NO_2 or PH_3 sensors.

Manual Calibration



WARNING

Calibrate the Innova in a “fresh air” environment (environment known to be free of combustibile and toxic gases and of normal oxygen content).

1. Hold down the **AIR** button for 3 seconds until the display counts down and the bar graph starts to scroll, then the display will read “**DONE**” once the “fresh air” reading for all active sensors is complete (20.9% for oxygen, 0 for all other sensors).



NOTE

After you complete the fresh air adjustment, a “**XXX**” may appear on the display screen in place of a sensor reading. The buzzer and lights will be on steady, see the Calibration Alarms section at the end of this chapter to respond to this message.

2. Press and hold ↑ and ↓ for 3 seconds. The “**FEATURES MENU**” appears on the display and counts down from 3 seconds. Then displays “**BEGIN CAL**”.
3. Press → to accept and begin calibration. If a Calword has not enabled, the “**AUTO CAL**” screen is displayed.



NOTE

If prompted by “**CALWORD**” and “*******”, enter a password, see Entering CalWord earlier in this chapter.

4. With the “**AUTO CAL**” message displayed. Press the ↓ to advance to the “**MAN CAL**” screen. Press → to accept “**MAN CAL**”.
5. The screen displays the first active sensor. Press the → to accept or press ↓ to advance to the next gas depending on what sensor you want to calibrate. To accept the desired selection, press →.
6. The default gas concentration is displayed with the ADJ icon and a double beep to indicate you may change the default concentration. The default concentration is set in the Auto Cal Gas Value, see Chapter 4, User Program, Setting Auto Cal Gas Values.
7. Press ↑ or ↓ to adjust the value to match the concentration of the calibration gas as read on the cylinder label.
8. Press → to accept the displayed concentration. The display reads “**BEGIN MAN CAL**” alternating with “**APPLY XX GAS**” (where XX is the gas selected) and counts down from 45 seconds. If no gas is detected during this period, the screen returns to “**BEGIN CAL**”
9. Attach the tubing from the regulator to the probe tube, the Innova will draw gas from the gas cylinder.

When gas is detected, the display will read “**CAL IN PROCESS**” for XX seconds, with the SPAN icon on. Then the screen displays “**CAL TIME LEFT**” (counting down) alternating with the gas reading.



NOTE

During calibration, logging is disabled but calibration events are recorded in the log.

10. When calibration is complete, the display reads “**MAN CAL PASSED**” and then alternates between “**>ACCEPT, ABORT**” and the gas reading. The gas label alternates with “**PASS**”.
11. Press → to accept. The display will show “**CAL ACCEPTED**”, and then alternate between “**REMOVE GAS**” and the all active sensors gas readings.



NOTE

If the calibration gas used interferes with any of the other sensors a non-zero reading may result, this does not affect the calibration of those sensor(s).

12. If you choose to abort, press ↓ to scroll to “**ABORT**” then → to accept the abort option. The display will read “**CAL ABORTED**” and then alternate between “**REMOVE GAS**” and all active sensor gas readings.

**NOTE**

The “**WEAK**” or “**FAIL**” flag may appear in place of the “**PASS**” flag in the case of a weak or failed sensor. See the instructions in the Sensor Failed Alarms section later in this chapter for corrective action.

13. Remove the tubing from the probe. After fresh air has been detected, the display will alternate between “**ALARMS SILENCED**”, and the readings, and then return to the normal operating mode, after an “**ALARMS ACTIVE**” message is displayed.
14. Unscrew the regulator from the cylinder, leave the components of the calibration kit assembled for convenience and place in the storage case.

Calibration Alarms

The Innova may alert you to one or more of the following alarms during calibration:

- Sensor Failed Alarm
- Weak Sensor
- Calibration Incomplete

Sensor Failed Alarm

If you attempt to air adjust or calibrate a faulty sensor, the Innova alerts you with a Sensor Failed Alarm.

INDICATIONS

- The backlight turns on automatically.
- The gas reading is replaced by XXX.
- Lights and Buzzer are steady.

RESPONDING TO A SENSOR FAILED ALARM

1. Complete the calibration procedure for the remaining sensors (if applicable), then return to the normal screen. The normal screen will continue to notify you of the sensor failure with a message.
2. Turn off the Innova, then verify that the sensor is installed properly, see Chapter 6, Maintenance, Replacing Sensors. Verify that the calibration gas value is correct in the Auto Cal Gas Valve Screen.
3. If the calibration gas value is correct, and the sensor is installed properly, turn the instrument on and repeat the air adjust and calibration procedures.
4. If the Fail condition persists, replace the sensor, see Chapter 6, Replacing Sensors, then calibrate the new sensor.



NOTE

You can enter the Innova User Program, Advanced Features Menu, and change the sensor status setting to **“OFF”**. All information for an **“OFF”** sensor is removed from the normal screen and recorded as a blank in the datalog.

Weak Sensor Warning

If the sensor that you are calibrating is nearing the end of its useful life, the Innova alerts you with a Weak Sensor message.

The gas flag will show **“WEAK”** at the conclusion of the calibration period.

RESPONDING TO A WEAK SENSOR

1. If you are manually calibrating the Innova, verify that you are correctly adjusting the gas concentration to match the concentration of the calibration gas. If using the Auto Cal method, verify that the gas concentration in the calibration gas cylinder matches the Auto Cal Gas Value, see Chapter 5, User Program, Setting Auto Cal Gas Values.



NOTE

A weak sensor is still functioning properly and can continue to be used. However, it is near the end of its useful life, and should be replaced as soon as possible, see Chapter 6, Maintenance, Replacing Sensors, for replacement instructions.

MAINTENANCE

This chapter contains maintenance information to ensure proper operation and reliability of the Innova Series gas monitor.



WARNING

Perform all procedures in a “fresh air” environment (environment known to be free of combustibles and toxic gases and of normal oxygen content).

Preventive Maintenance

The following are daily, monthly, quarterly, and “as required” preventive maintenance suggestions to ensure the reliability of the Innova Series gas monitor.



NOTE

In instances where the Innova is in continual or everyday use, **Thermo GasTech** recommends that you perform preventive maintenance procedures more often than suggested in the following sections.

Daily

BATTERIES

The Innova should always contain fully-charged NiCd batteries or sufficiently powered alkaline batteries before each day’s use. You can verify the capacity of the batteries using the Display Menu. To verify battery capacity:

1. Press and hold the **RANGE** button, for three beeps, then release the button.

If the display shows less than three bars, recharge the NiCd batteries or replace the alkaline batteries as described later in this chapter.

2. Press the ↑ or ↓ buttons to scroll to exit.
3. Press → to return to the normal operation mode.

CALIBRATION

For **optimum** efficiency of the monitor, calibrate the Innova **before** each use. If multiple calibrations over a period of days indicate that only a minimum of adjustments are required, the frequency of calibration can be changed to weekly or monthly, depending on how often the monitor is used, and how demanding the monitoring environment is.



NOTE

At the very least, “challenge” the normal operation of the oxygen (O₂) sensor (if applicable) before every use.

Exhale over the inlet of the probe as you watch the display. The O₂ reading should **decrease**. When the O₂ reading decreases to **19.5%**, the alarm should activate. This confirms normal operation of the O₂

SAMPLE-DRAW SUBCOMPONENTS

Verify the proper operation of the flow alarm circuit by holding your finger over the inlet of the probe for a few seconds. The pump shuts off, “**PUMP FAILED**”, and “**PRESS → TO CLEAR**” alternate with the gas readings display, the spinning icon changes to an “**X**”. The audible alarm sounds every second alternating/beeping. Press → to restart the pump circuit. The icon will change from an “X” or failed condition, and the pump will restart.

Monthly/Quarterly

CALIBRATION

Calibrate the sensors at least every one to three months. Calibration frequency depends on the frequency of use and also the environmental conditions in which you use the Innova.

As Required

ALARM CIRCUITS

Periodically verify that all visual and audible alarms function properly.



WARNING

Verify alarm circuits in a “fresh air” environment (environment known to be free of combustibles and toxic gases and of normal oxygen content).

To verify the alarm circuits, use a concentration of the proper gas sample that is greater than the preset warn or alarm levels. Verify that the LEDs illuminate and the buzzer sounds. Also verify that the display reading in alarm flashes during the alarm sequence.

SAMPLE-DRAW SUBCOMPONENTS

Periodically check the probe, hoses, internal filter, and tubing for obstructions that can accumulate over time. *This is especially important if you use the Innova in a dusty or dirty environment.* Replace the cotton and hydrophobic filter elements if they become contaminated or discolored.



WARNING

Operation of instrument without probe/filter assembly attached will result in pump damage and possible impaired performance. Do not operate without probe/filter assembly attached.

Troubleshooting



NOTE

See Chapter 3, Start Up & Operation, for any of the various alarm indications that you may encounter while the Innova Series gas monitor is in normal use.

The troubleshooting section on the following pages describes symptoms and probable causes and recommends action for problems you may encounter with the Innova.

Table 6-1 Troubleshooting

Condition	Symptom(s)	Probable Cause(s)	Recommended Action
Unable to recharge NiCd batteries	<ul style="list-style-type: none"> • The battery charger does not indicate that the batteries are receiving a charge. • After recharging, the batteries do not have a sufficient charge. 	<ul style="list-style-type: none"> • The battery selector switch is set to ALK. • The batteries are not installed or alkaline batteries are installed. • The batteries are defective. • The battery charger is defective. 	<ol style="list-style-type: none"> 1. Verify that the battery selector switch is set to NI-CAD. 2. Verify that NiCd batteries are installed. 3. Replace the batteries. 4. Attempt to recharge the batteries with a different battery charger (same type). If the condition clears, the battery charger is defective. 5. If the difficulty continues, contact Thermo GasTech, for further instruction.
Unable to use the battery charger as a continuous operation adapter	<ul style="list-style-type: none"> • You cannot operate the Innova with the battery charger/continuous operation adapter in place. 	<ul style="list-style-type: none"> • The battery selector switch is set to ALK. • The batteries are not installed or alkaline batteries are installed. • The battery charger is supplying a voltage that is too high. • The battery charger is defective. 	<ol style="list-style-type: none"> 1. Verify that the battery selector switch is set to NI-CAD. 2. Verify that NiCd batteries are installed. 3. If you are using the battery charger as a continuous operation adapter for longer than an 8-hour period, disconnect then reconnect the battery charger to restart the charging timer. 4. Replace the batteries. 5. Use a different battery charger (same type) as a continuous operation adapter. If the condition clears, the battery charger is defective. 6. If the difficulty continues, contact Thermo GasTech, for further instruction.

Table 6-1 Troubleshooting (Continued)

Condition	Symptom(s)	Probable Cause(s)	Recommended Action
Unable to calibrate a sensor (except O ₂ sensor)	<ul style="list-style-type: none"> • You cannot set the sensor's "fresh air" reading to zero. • Sensor shows "xxx". 	<ul style="list-style-type: none"> • The gas cylinder is empty or out-dated. • The sensor is defective. 	<ol style="list-style-type: none"> 1. Verify that the gas cylinder contains an adequate and fresh supply of the calibrating gas. 2. Replace the sensor as described later in this chapter. 3. If the difficulties continue, contact Thermo GasTech, for further instruction.
Unable to calibrate a sensor (O ₂ sensor only)	<ul style="list-style-type: none"> • You cannot fresh air the O₂ reading to 20.9. 	<ul style="list-style-type: none"> • The O₂ sensor is defective. 	<ol style="list-style-type: none"> 1. Replace the O₂ sensor as described later in this chapter. 2. If the difficulties continue, contact Thermo GasTech, for further instruction.

Recharging NiCd Batteries



WARNING

Recharge the batteries only in a “fresh air” environment (environment known to be free of combustible and toxic gases and of normal oxygen content).

Check NiCd battery capacity by using the Display Menu, see Chapter 4, User Program.



CAUTION

For optimum battery capacity, the batteries should be fully depleted before you recharge them. Repeated recharging of partially discharged batteries will reduce the battery capacity and operating time of the batteries.

Use only the battery chargers listed in Appendix A, Parts Lists, to recharge the batteries.

1. Verify that the battery selector switch is set to **NI-CAD**.
2. Verify that the voltage listed on the battery charger is the same as the AC outlet (115V or 220V), then plug the charger into the outlet.
3. Plug the other end of the charger into the **CHGR** jack at the side of the Innova.
4. Verify that the charger's amber light goes on. Allow the batteries to charge for at least 8 hours. Once the batteries are fully charged, the green light on the charger goes on (the amber light remains on).



NOTE

If the switch position is in the NI-CAD position, and alkaline batteries are installed, the battery charger will not charge alkaline batteries. If you attempt to recharge alkaline batteries, the amber light on the battery charger will flash.

A completely depleted battery recharges in approximately eight hours. The battery charger automatically cuts the charging current to a sustaining rate when the batteries are fully recharged. You can leave the charger plugged in indefinitely.

Replacing Components

**WARNING**

Replace components in a “fresh air” environment (environment known to be free of combustible and toxic gases and of normal oxygen content).

Replacing Batteries

**WARNING**

When replacing batteries, use only the batteries supplied by Thermo GasTech (refer to Appendix A, Parts List). They are a special, high capacity type and are required to maintain agency certification of your Innova Series.

- Duracell MN1300 (Alkaline)
- SAFT 410907-104 (NiCd)

To maintain Cenelec certification of your Innova Series monitor, the hex head screw must be installed to secure the battery lid in place.

1. Turn off the Innova by pressing and holding the **ON/OFF** button while the Innova sounds three beeps.
2. Turn the captive screw at the middle of the battery compartment door counterclockwise, then remove the door.
3. Remove all four spent batteries.
4. Verify that the **ALK/NI-CAD** switch is set to the proper setting, see Chapter 6, Maintenance, Figure 6-1 Innova Battery Compartment.

**WARNING**

Never mix NiCd batteries together with alkaline batteries, this can cause internal damage to the monitor.

5. Install four new batteries (refer to the raised picture in the battery compartment for the proper orientation of the batteries).

**NOTE**

Always replace **all** four batteries at the same time

6. Install the battery compartment door and tighten screw until snug against gasket.

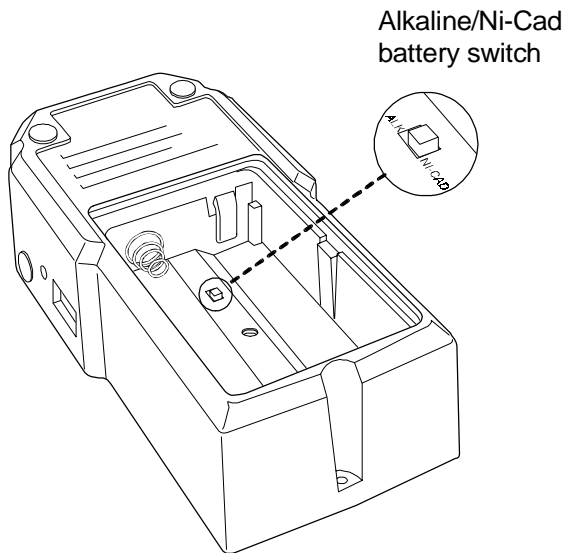

Figure 6-1 Innova Battery Compartment



WARNING

If applicable, follow all federal, state, or local regulations regarding the disposal of alkaline and NiCd batteries.

Some toxic gas sensors require up to 15 minutes to stabilize, after you install the batteries. If your Innova includes a toxic gas sensor(s), do not turn on and use the Innova during this period. If the unit is started up immediately after installing batteries, the “BIAS” message may appear, see Chapter 6, Maintenance, for instructions on installing or recharging batteries.

Replacing Sensors



WARNING

Recalibrate the Innova whenever you replace a sensor.

If applicable, follow all federal, state, or local regulations regarding the disposal of electrochemical sensors. The toxic sensors contain sulfuric acid. The O₂ sensor contains an alkali solution.

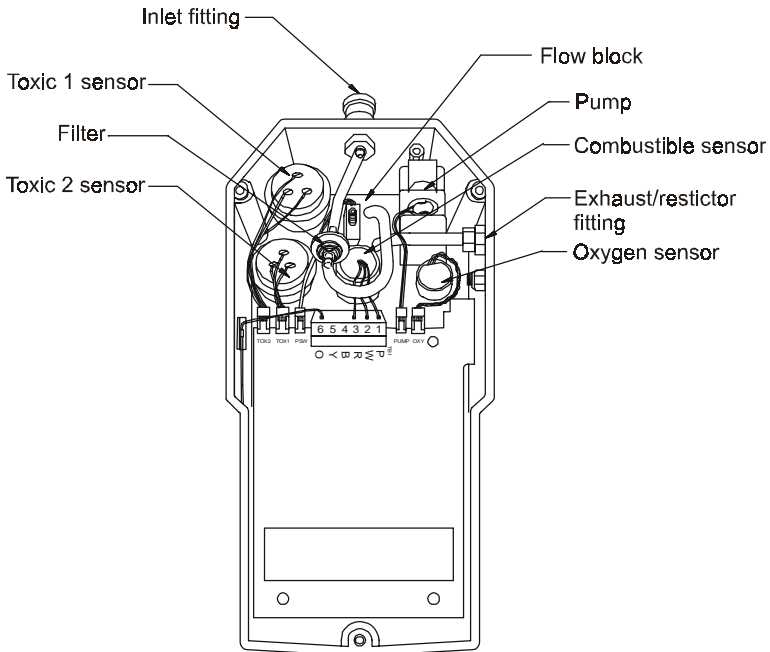

Figure 6-2 Innova Series Sensor Locations and Connection Assignments

1. Turn off the Innova.



CAUTION

To avoid damage to internal circuitry, remove the batteries before opening the main housing.

2. Open the Innova, then separate the two halves.
3. Locate the sensor you want to replace in the flow block, see Figure 6-2.

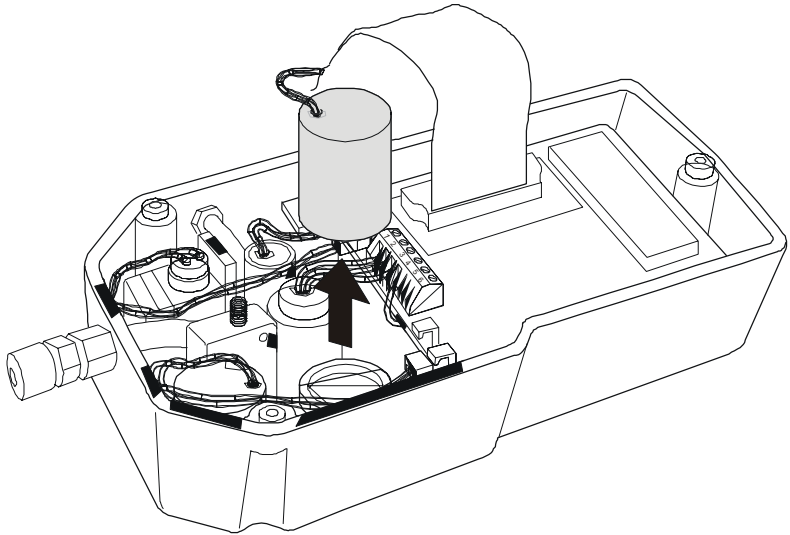

Figure 6-3 Removing a Sensor from the Innova



NOTE

Figure 6-2 illustrate sensor assignments for the standard Innova. The sensor assignment for your Innova may be different depending on the Innova model you are using. For models that have less than four sensors, empty sensor cavities are filled with sensor plugs.

4. Disconnect or unplug the sensor's connection to the Innova.



CAUTION

If you use a tool to loosen the sensor from the flow block, be careful not to damage the sensor housing or the flow block.

5. Using your fingers, tilt the sensor from side to side to loosen it, then pull the sensor straight out of its flow block cavity, see Figure 6-3.
6. Insert the replacement sensor into the cavity, then apply downward pressure on top of the sensor until it is firmly seated in the cavity. For toxic sensors, make sure not to bend or damage the sensor pins.
7. Reconnect the sensor's connection to the Innova main board.

For the combustible gas sensor, connect the purple, white, and red wires to the proper terminals (**P**, **W**, **R**) on the terminal block (**TB1**).

For the remaining sensors, plug the sensor wire connector into the applicable socket (**OXY**, **TOX1**, or **TOX2**).

8. Close the Innova housing and re-install batteries.

**CAUTION**

Some toxic gas sensors require up to 15 minutes to stabilize, after you install the batteries. If your Innova includes a toxic gas sensor(s), do not turn on and use the Innova during this period. If the unit is started up immediately after installing batteries, the “BIAS” message may appear, see Chapter 6, Maintenance, for instructions on installing or recharging batteries. Calibrate the Innova before you use it again.

Replacing the Pump

**CAUTION**

To avoid damage to internal circuitry, remove the batteries before opening main housing.

1. Turn off the Innova, then separate the halves.
2. Locate the pump in the flow block, see Figure 6-2.
3. Disconnect the pump wire connector from the main board socket labeled **PUMP**.
4. Remove the nut that secures the pump bracket to the pump, then remove the bracket.
5. Remove the pump from the flow block by rocking it back & forth.

**CAUTION**

When you insert the new pump, do not place pressure on the pump motor. The pump motor is the dark-colored circular component at the top of the pump.

6. Before installing the new pump, apply a thin film of petroleum jelly lubricant or O-ring grease to the outside of the barbs. Be careful not to get lubricant into the end of the barbs, as this could clog the pump.

**CAUTION**

Do not use lubricant that contain silicone, as this can poison the combustible sensor.

7. Place the pump bracket in its previous position, then secure the bracket to the pump with the nut you removed in step 4.
8. Reconnect the pump wire connector to the main board socket labeled **PUMP**, close and secure the Innova housing, and re-install batteries.

Replacing the Internal Filter



CAUTION

To avoid damage to internal circuitry, remove the batteries before opening main housing.

1. Turn off the Innova, remove batteries, and then separate the halves.
2. Locate the internal filter, see Figure 6-2. It is connected to the inlet fitting by a small polyurethane tube.
3. Disconnect the polyurethane tubes from the slip-on barbs on the filter.
4. Push the tubes onto the barbs on the new filter, close and secure the Innova, and re-install batteries.

Replacing the Probe's Hydrophobic Filter

1. Unscrew the probe body's two halves. Be careful not to lose the o-rings that seal the filter.
2. Remove the filter and cotton ball from the probe half that mounts to the Innova (you may need to use a small screwdriver to pry the filter loose).
3. Install the new filter and cotton ball in place of the filter and cotton ball you removed.
4. Make sure the O-rings are in place, then reassemble the probe halves.

Appendix
A

PARTS LIST

Table A-1 lists replaceable parts and accessories for all Innova Series.

Table A-1 Parts List and Accessories

Part No.	Description
06-1255	Tubing, polyurethane, 5/16 in. OD x 3/16 in. ID
10-0491	Screw, hex head
13-0110	Shoulder strap, adjustable
20-0650	Carrying case, Innova Series instrument
20-0651	Case, confined space kit (case only)
30-0042	Pump
30-0044	Kit, rebuild pump (30-0042/30-0042-01)
33-0152-01	Filter, Hydrophobic (for 80-0187 probe)
33-0160	Filter, internal
33-1031	Cotton ball, pkgs. of 24 (for 80-0187 probe)
49-1201	Battery, alkaline, D size
49-1501-01	Battery, NiCd, D size
49-2149	Charger, NiCd batteries, dual-rate, 230 VAC
49-2150	Charger, NiCd batteries, dual-rate, 115 VAC
49-2151	Charger, NiCd batteries, dual-rate, 12 VDC
52-2033	Remote audible alarm, with lapel clip
52-2033-01	Remote audible alarm, with 20-foot cord and magnet
61-0123	Sensor, combustibles (LEL/ppm)
65-0612	Sensor, oxygen (O ₂)
65-0613	Sensor, oxygen (Fuel Vapor only)
65-2417	Sensor, sulfur dioxide (SO ₂)
65-2426-01	Sensor, carbon monoxide (CO)
65-2426-02	Sensor, hydrogen sulfide (H ₂ S)

Table A-1 Parts List and Accessories

Part No.	Description
65-2431-01	Sensor, chlorine (Cl ₂)
65-2431-02	Sensor, hydrogen cyanide (HCN)
65-2431-03	Sensor, nitrogen oxide (NO)
65-2431-07	Sensor, ammonia (NH ₃)
65-2431-08	Sensor, phosphine (PH ₃)
65-2431-10	Sensor, nitrogen dioxide (NO ₂)
71-6416	Quick Reference Card
71-6417	Operator's Manual
77-0043	Kit, Cenelec (includes allen wrench and hex head screw)
80-0187	Probe with hydrophobic filter
80-0187-04	Probe, fiberglass, 30-inch, with hydrophobic filter
80-0211	Moisture trap
80-0405	Dilution fitting, 50%
80-0504	Hose, teflon, 3 feet (for Cl ₂ /Fuel & Soil Vapor)
80-0505	Hose, polyurethane, 5 feet
80-0511	Hose, polyurethane, 10 feet
80-0516	Hose, polyurethane, 15 feet
80-0520	Hose, polyurethane, 20 feet
80-0525	Hose, polyurethane, 25 feet
80-0530	Hose, polyurethane, 30 feet
80-0550	Hose, polyurethane, 50 feet
80-0599	Hose, polyurethane, 100 feet
81-0002	Cylinder, 2% H ₂ (17 liter)
81-0007	Cylinder, 40% LEL hexane (17 liter)
81-0012	Cylinder, 50% LEL CH ₄ (17 liter)
81-0064	Cylinder, 50 PPM CO (17 liter)
81-0078	Cylinder, 100% N ₂ (17 liter)
81-0151	Cylinder, 25 PPM H ₂ S (58 liter)
81-0153	Cylinder, 50% LEL CH ₄ / 40% CO ₂ /10% N ₂ (17 liter)

Table A-1 Parts List and Accessories

Part No.	Description
81-0154	Cylinder, 50% LEL CH ₄ /25 PPM H ₂ S/50 PPM CO/12% O ₂ (58 liter)
81-0155	Cylinder, 50% LEL CH ₄ /50 PPM CO/12% O ₂ (103 liter)
81-0170	Cylinder, 5 PPM SO ₂ (58 liter)
81-0175	Cylinder, 25 PPM NO (58 liter)
81-0180	Cylinder, 5 PPM NO ₂ (58 liter)
81-0190	Cylinder, 5 PPM Cl ₂ (58 liter)
81-0191	Cylinder, 25 PPM NH ₃ (58 liter)
81-0192	Cylinder, 10 PPM HCN (58 liter)
81-0193	Cylinder, 0.5 PPM PH ₃ (58 liter)
81-0226-01	Cal kit, O ₂
81-0226-02	Cal kit, CH ₄
81-0226-03	Cal kit, CO
81-0226-04	Cal kit, CH ₄ (Land Surveyor)
81-0226-05	Cal kit, Hexane (Soil Vapor)
81-0226-06	Cal kit, Hexane/O ₂ (Fuel Vapor)
81-0226-07	Cal kit, H ₂ (Transformer Gas Tester)
81-0226-08	Cal kit, H ₂ /O ₂ (Transformer Gas Tester)
81-0227-01	Cal kit, H ₂ S
81-0227-02	Cal kit, Cl ₂
81-0227-03	Cal kit, HCN
81-0227-04	Cal kit, NH ₃
81-0227-05	Cal kit, NO
81-0227-06	Cal kit, NO ₂
81-0227-07	Cal kit, SO ₂
81-0227-08	Cal kit, PH ₃
81-0227-09	Cal kit, CH ₄ /O ₂ /CO
81-0227-10	Cal kit, CH ₄ /O ₂ /CO/H ₂ S
81-0227-11	Cal kit, CH ₄ /O ₂ /CO/Cl ₂
81-0227-12	Cal kit, CH ₄ /O ₂ /CO/HCN

Table A-1 Parts List and Accessories

Part No.	Description
81-0227-13	Cal kit, CH ₄ /O ₂ /CO/NH ₃
81-0227-14	Cal kit, CH ₄ /O ₂ /CO/NO
81-0227-15	Cal kit, CH ₄ /O ₂ /CO/NO ₂
81-0227-16	Cal kit, CH ₄ /O ₂ /CO/SO ₂
81-0227-17	Cal kit, CH ₄ /O ₂ /CO/PH ₃
81-0227-18	Cal kit, CH ₄ /O ₂ /H ₂ S/HCN
81-0227-19	Cal kit, CH ₄ /O ₂ /H ₂ S/NO
81-0227-20	Cal kit, CH ₄ /O ₂ /H ₂ S/SO ₂
81-0228-01	Cal kit, CH ₄ /O ₂ /Cl ₂ /NO
81-0228-02	Cal kit, CH ₄ /O ₂ /Cl ₂ /PH ₃
81-0228-03	Cal kit, CH ₄ /O ₂ /HCN/NH ₃
81-0228-04	Cal kit, CH ₄ /O ₂ /HCN/NO
81-0228-05	Cal kit, CH ₄ /O ₂ /HCN/PH ₃
81-0228-06	Cal kit, CH ₄ /O ₂ /NH ₃ /NO ₂
81-0228-07	Cal kit, CH ₄ /O ₂ /NH ₃ /PH ₃
81-0228-08	Cal kit, CH ₄ /O ₂ /NO/NO ₂
81-0228-09	Cal kit, CH ₄ /O ₂ /NO/PH ₃
81-0228-10	Cal kit, CH ₄ /O ₂ /NO ₂ /PH ₃
81-0228-11	Cal kit, CH ₄ /O ₂ /SO ₂ /PH ₃
81-0228-12	Cal kit, CH ₄ /O ₂ /CO (Land Surveyor)
81-0228-13	Cal kit, CH ₄ /O ₂ /H ₂ S (Land Surveyor)
81-1063	Regulator, demand flow (34/58/103 liter cylinders)
81-1064	Regulator, demand flow (17 liter cylinders)
81-6500	Confined space kit (non H ₂ S)
81-6501	Confined space kit (any H ₂ S version)
82-0200	1/8" hex wrench
82-5032	Cable, serial
82-5071	Data retrieval kit

INTERFERENCE FACTORS

The following factors interfere with the accurate gas measurement capability of the Innova:

- Filament poisoning
- Rich mixtures
- Oxygen-deficient mixtures
- Oxygen-enriched mixtures
- Interfering gases
- Response to various combustible gases

Filament Poisoning

Silicone vapors and chlorine and fluorine compounds, such as chlorinated hydrocarbons, can damage the HC sensor and interfere with accurate LEL readings.

Such compounds, even in small proportions, should be avoided. Verification checks on known gas samples are necessary, if the possibility of exposure to these compounds exists.

High Concentration of Combustible Gas

With rich mixtures of combustible gases, the instrument displays the following indications (refer to Table B-1)

Table B-1 Indications with High Combustible Gas Concentrations

Cause	Indication
Mixtures up to 100% LEL	Reading displayed.
Mixtures between LEL and Upper Explosive Limit (UEL)	100% displayed.
Mixtures above the UEL	The reading increases to 100% LEL, then comes back down. Very rich mixtures read close to zero.

Oxygen-Deficient Mixtures

Samples containing less than 10% oxygen may give low LEL readings by starving the combustible gas reaction in the sensor. Such mixtures will also cause a low oxygen alarm. As a rule, 10% oxygen or more gives a full reading on any combustible gas up to the LEL.

Oxygen-Rich Mixtures

Samples containing combustible gases that have more than normal proportion of oxygen will give a normal reading. However, they should be avoided because the flame arrestor used is not dense enough to arrest flames from combustible gas in oxygen. Such mixtures will also cause a high oxygen alarm.



WARNING

Do not attempt to use the Innova on samples of combustible gas in oxygen; for example, oxy-acetylene mixtures. Instead, use sample mixture in air.

Interfering Gases

The CO sensor responds to some other gases besides CO. The CO sensor has a charcoal filter that prevents interference from H₂S and some of these other gases. However, continuous exposure may saturate the filter and break through as CO indication. Hydrogen, ethylene, and acetylene will pass quickly through the filter, and thus are strong interferences, while heavier olefins and aromatic hydrocarbons will break through in time, making sensor replacement necessary.

Relative Combustible Response

The Innova is normally calibrated with methane gas, but responds to a variety of hydrocarbons (refer to Table B-2).

Table B-2 Relative Response of New Innova Series LEL/ppm Hydrocarbon Indicator to Various Gases and Vapors

GAS or VAPOR	LEL RANGE			PPM RANGE	
	% LEL VOL	CONVERSION FACTOR:		CONVERSION FACTOR:	
		VS. HEXANE	VS. METHANE	VS. HEXANE	VS. METHANE
Acetone	2.5	0.73	1.7	1.6	0.48
Acetylene	2.5	0.63	1.5	1.2	0.34
Benzene*	1.2	1.0	2.3	1.0	0.30
Butadiene, 1, 3-	2.0	0.52	1.21	0.98	0.29
Carbon Monoxide	12.5	0.39	0.9	5.9	1.8
Chloroform*	NONE	-	-	9.8	3.0
Dimethyl Formamide*	2.2	1.4	3.3	2.7	0.81
Ethyl Acetate*	2.0	0.9	2.1	1.6	0.48
Ethyl Alcohol	3.3	0.70	1.6	2.1	0.64
Heptane	1.05	1.00	2.3	0.99	0.30
Hexane	1.1	1.00	2.3	1.0	0.30
Hydrogen	4.0	0.33	0.7	1.3	0.39
Methane	5.0	0.43	1.0	3.3	1.0
Methyl Chloroform	7.5	0.68	1.6	4.9	1.5
Methyl Ethyl Ketone	1.4	1.09	2.5	1.7	0.52
Pentane	1.5	0.71	1.7	1.0	0.30
Propane	2.1	0.56	1.3	1.3	0.39
Propyl Acetate*	1.7	0.77	1.8	1.4	0.42
Propyl Alcohol, iso-	2.0	0.89	2.1	1.9	0.58
Propyl Alcohol, n-	2.2	0.81	1.9	1.9	0.58
Styrene Monomer	0.9	4.2	9.7	2.7	0.82
Toluene	1.1	1.2	2.9	1.2	0.36
Trichloroethylene	8.0	1.0	2.4	6.8	2.1
Xylenes, isomer mix	.9-1.1	3.0	7.0	1.7	0.52

* These response factors are estimates, based on factors for 6 volt GasTechTor sensor adjusted for characteristics of Innova sensor.

Please note that response varies from one sensor to another and the relative response of a sensor can change with the age of the sensor. These data should be used for estimation purposes only.

Assuming an instrument calibrated directly for hexane or methane, but used to observe a different gas, the equivalent response in % LEL (or ppm) for that gas is secured by multiplying the observed% LEL (or ppm) reading by the LEL (or ppm) scale conversion factor.

SUPPLEMENTAL INSTRUCTIONS

Innova Land Surveyor (LS)

The Innova LS consists of two different models (PPM/% LEL/% GAS and PPM/%LOW/%HI) that permits measurements of methane gas in three ranges of sensitivity:

Table C-1 Ranges for Innova LS

PPM/%LEL/%GAS	PPM/%LOW/%HI
0-10,000 PPM	0-10,000 PPM
0-100% LEL	0-5.0% Gas by VOL [%LOW], equivalent to 0-100% LEL
0-100% GAS by VOL*	0-100% Gas by VOL [%HI]*

* By means of Thermal Conductivity Sensor

Operation

For the PPM/%LOW/%HI, see the text in brackets [].

Operation in the first two ranges is exactly as described in the text of this manual, except that if the PPM reading should exceed its range (10,000 PPM) the range will automatically switch to the % LEL [%LOW] range. If the % LEL [%LOW] reading should exceed 100% LEL, equivalent to 5% methane, the Innova LS will automatically switch to the 0-100% GAS range [%HI] range. The display will show the legend “% GAS” [“%HI”] following the gas reading while in this range.

The % GAS [%HI] range may also be entered manually from the % LEL [%LO] range by pressing the RANGE button twice. If it is likely that high concentrations will be encountered, to prolong the life of the LEL/PPM sensor, start out in the % GAS [%HI] range. The Innova LS does not automatically range down. To exit the % GAS [%HI] range and return to the LEL [%LOW] range press the RANGE button twice. There is a 30 second warm-up period after the transition, during this period the display count from W 30 to W 1 before gas readings are displayed. To manually switch between the ppm and % LEL (%LO) ranges, press the RANGE button once.



NOTE

If the sample is very high in methane content and also very low in oxygen content, the unit may not auto-range upscale. If during sampling the % LEL [%LOW] indication rises rapidly and then decays, manually switch to the % GAS [%HI] range as described above to determine the methane content.

Precautions

Be aware that the methane/air mixtures in the range 5% to 15% by volume are highly explosive. The Innova is Intrinsically Safe, and is not a source of ignition, but there are many common ignition sources such as static electrical discharges or sparks from metal tools that can ignite such mixtures. The relationship between ranges is correct only for methane. Some rough approximations may be made for gases such as propane and butane, but values will not be accurate, and should not be used for safety considerations.



WARNING

Initiate Fresh Air Zero adjustment only in a non-hazardous environment free of combustible or toxic gas content and consisting of normal oxygen content. To do otherwise could cause a serious error in the indicated gas level shown on the display, and result in failure of the Innova LS to properly indicate the degree of hazard. Also, use care not to initiate Fresh Air Zero immediately after a range change, as this can cause an error in the “clean air” baseline.

Land Surveyor Calibration (Auto)

Calibration is as described earlier in this manual, with one exception: the % GAS [%HI] sensor is calibrated separately from the Catalytic (PPM/%LEL or PPM/%LO) sensor. Therefore a multi-step calibration process has been programmed into the Auto Calibration routine. First, the standard sensors are calibrated using a multi-gas mixture. Then TC sensor is calibrated using a multi-gas cylinder, containing 50% CH₄ (Methane), CO₂ (Carbon Dioxide), and N₂ (Nitrogen).

1. A separate air adjust is required for the % LEL and % GAS ranges. Perform an air adjust in the % LEL and % GAS ranges before calibration.
2. Begin the calibration process by performing an Auto Calibration. The TC sensor will be ignored during the multi-gas calibration.
3. When the multi-gas Auto Calibration is complete, a double beep prompts the user to begin the TC sensor calibration. The default gas concentration is displayed with the ADJ icon to indicate you may change the concentration. If the concentration on the gas cylinder does not match the concentration displayed.
4. Press to begin the calibration.
5. Apply the calibration gas and follow the prompt to complete the calibration process.

Land Surveyor Calibration (Manual)

Manual calibrations are performed as described in Chapter 5, Calibration. Once in the manual calibration screen, the location of the sensor(s) are as illustrated below (CH₄/O₂ version shown).

CH4	O2
	TC

1. Press → to accept or ↓ to advance to the next gas depending on what sensor you want to calibrate.

Pump

The Land Surveyor uses a pump capable of drawing a sample from a source that is at a vacuum of up to 60" of water column. If pump replacement is required, the pump listed in the Parts List below must be specified. Parts List

Parts List

See Parts List in Appendix A for a more complete list of replacement parts and accessories.

Replacement Parts

- 30-0042-01 Pump, Land Surveyor
- 61-0124 Sensor, Thermal Conductivity
- 81-0012 Cylinder, 50% LEL CH₄ (17 liter)
- 81-0226-04 Cal kit, CH₄
- 81-0228-12 Cal kit, CH₄/O₂/CO
- 81-0228-13 Cal kit, CH₄/O₂/H₂S
- 81-0153 Cylinder, 50% CH₄/40% CO₂/10% N₂ (% gas range) (17 liter)
- 81-0154 Cylinder, 50% LEL CH₄/25 PPM H₂S/50 PPM CO/12% O₂ (58 liter)
- 81-0155 Cylinder, 50% LEL CH₄/50 PPM CO/12% O₂ (103 liter)
- 81-1063 Regulator, demand flow (34/58/103 liter cylinders)
- 81-1064 Regulator, demand flow (17 liter cylinders)

Innova Transformer Gas Tester (XT)

Overview

The Innova Transformer Gas Tester is factory configured to monitor for total combustibles from the gas space of power transformers. If transformer faults, such as overheating, hot spots, arcing or corona occur, various combustible gases are generated. If left unchecked, gas can accumulate creating a potential for explosion, failure of the transformer, significant remediation costs and loss of electrical service.

The Innova Transformer Gas Tester is designed as an inspection tool to determine if unacceptable levels of gas exist within the transformer. A sample of gas is extracted from the headspace of the transformer by the Innova Transformer Gas Tester with a 1:1 dilution fitting in place. If gas levels exceed acceptable levels, additional inspection, including performing a dissolved gas analysis, is required to determine fault condition and appropriate action. If oxygen detection is required, an optional oxygen range can be provided.

Detection Range

The Innova Transformer Gas Tester has two detection ranges: 0-100% LEL and 0-10,000 ppm combustibles. An optional range of 0-30% oxygen can be provided if requested.

The Innova Transformer Gas Tester is calibrated with 2% hydrogen (50% LEL) in the LEL range.

Alarm Points

The alarm points for the combustibles (LEL) range are preset at 10% LEL (WARN) and 50% LEL (ALARM). PPM combustibles alarms are set at 1000 and 5000 ppm. All alarms are completely user adjustable if alternate alarm points are required. Refer to Chapter 4, Edit Alarms, for alarm adjustment instructions.

The Innova Transformer Gas Tester can also be provided with an optional oxygen channel. The oxygen channel has two user adjustable alarms, one that activates at 19.5% decreasing oxygen and one that activates at 23.5% increasing oxygen.

Dilution Fitting

The Innova Transformer Gas Tester includes a dilution fitting to provide the necessary dilution ratio to mix one part sample with one part air.

Description

The catalytic detection method requires oxygen in order to function properly. In an inert gas environment, it is necessary to provide oxygen by the use of a dilution attachment on the inlet fitting to oxidize the combustible gas.

The dilution fitting consists of a small tee fitting which plugs into the inlet fitting of the instrument. It includes two small drilled orifices. One orifice connects to the sample source and the other to atmospheric air. These are proportioned to give a dilution of one part air to one part of sample.

If testing for combustible gas in a inert environment is attempted without the dilution fitting, the Innova will respond briefly as the available oxygen is exhausted in the flow block and the combustible readings will then return to zero, providing an incorrect reading.

For testing oxygen content in transformers, the dilution fitting can be removed. This will allow you to determine if there is oxygen present. This test however, can only be performed with the Innova Transformer Gas Tester with an active oxygen channel.

Operation

Before operating the **Thermo** GasTech Innova Transformer Gas Tester, it is important that you read and understand the Innova Series Operator's Manual. It is also extremely important that you are familiar with the specific transformer that you are testing and know how to safely extract a gas sample.

1. Turn on the Innova Transformer Gas Tester and allow the instrument to warm up.
2. Perform fresh air adjustment as described in Chapter 2, Start Up & Operation.
3. Connect the probe directly to the end of the Innova Transformer Gas Tester.
4. Open the valve on the Tedlar bag by turning the top of the valve counter clockwise two full turns.

5. To remove excess air from the Tedlar bag, connect the tubing from the Tedlar bag to the end of the probe allowing the internal pump to draw the air out of the gas collection bag. When the Innova alarms and indicates “PUMP FAILED”, turn the valve clockwise until it is completely closed, then remove the tubing from the end of the probe.
6. Press the → button to restart the pump.
7. Remove the probe and attach the dilution fitting directly to the inlet fitting of the Innova.
8. Attach the probe to the dilution fitting.
9. Attach the Tedlar bag tubing to the gas sample port of the transformer.
10. Open the valve on the bag two full turns then fill the bag with gas from the head space of the transformer, closing the valve when the bag is full.
11. Remove the gas collection bag.
12. Open the valve on the collection bag and attach the bag directly to the inlet of the probe on the Innova Transformer Gas Tester.
13. View the Innova Transformer Gas Tester display to determine the concentration of combustible gas in the transformer.
14. Remove the gas collection bag from the probe when complete and close valve on bag.



NOTE

When testing for oxygen content, either remove the dilution fitting from the Innova Transformer Gas Tester or place your finger over the small orifice on the dilution fitting before performing test.

Calibration

The Calibration procedure for the transformer gas tester version is identical to the procedure as outlined in the calibration section of this manual. The calibration section of this manual. The calibration gas cylinder is 25% LEL Hydrogen, 12% Oxygen, balance Nitrogen. The Autocal gas value for the LEL range is 50% LEL, to provide the correct reading when the dilution fitting is used. The dilution fitting must be removed for calibration.

Parts List

See Parts List in Appendix A for a more complete list of replacement parts and accessories.

80-0405	Dilution fitting, 50%
81-0013	Cylinder, 1% H ₂ /12% O ₂ in N ₂
81-0227-22	Cal kit, H ₂ /O ₂ (Transformer Gas Tester)
81-1064	Regulator, demand flow (17 liter cylinders)
81-1155	Tedlar bag w/tubing

Soil Vapor (SV) and Fuel Vapor (FV)

Operation

The Soil Vapor Monitor has a combustible sensor only; the Fuel Vapor Monitor has an oxygen in addition to the combustible. The Soil and Fuel Vapor Monitors have two operating modes, “CH4” mode and “ME” mode. When in the “CH4” mode, the Innova functions as a normal instrument, and the unit will respond to all combustible gases, including methane. When in the “ME” (Methane Elimination) mode, the voltage to the combustible sensor is changed, which causes the sensor to respond only to non-methane combustible gases. This allows the user to discriminate between methane and non-methane hydrocarbons.

Table C-2 Sensor Specifications

Sensor	Sensor Type	Detection Range	Warn Setting	Alarm Setting	Accuracy (of reading)	Repeatability (of reading)
Hydrocarbon	Catalytic	0 to 100 % LEL	10 % LEL	50 % LEL	± 5%	± 2%
Hydrocarbon	Catalytic	0 to 1,000 ppm	100 ppm	500 ppm	± 10%	± 5%

Range and Mode Selection

After the Innova has completed its warm-up cycle, the letters “CH4” and “ME” will appear under the gas reading on the display, indicating the mode of operation. If desired, the mode may be changed by pressing the RANGE button twice.

To change the hydrocarbon range from LEL to PPM, press the RANGE button once.



CAUTION

Note that if the mode of operation is changed to “ME” mode, the unit will no longer respond to methane or natural gas. If it is suspected that methane or natural gas may pose a hazard, the unit should first be operated in the “CH4” mode to verify that no methane or natural gas is present.

Calibration

The Innova Soil and Fuel Vapor Monitors are calibrated to hexane, which is representative of fuel vapors and vapors typically found in contaminated soil.



NOTE

The Innova Soil and Fuel Vapor Monitors use a 3 foot teflon-lined hose to minimize absorption of hydrocarbon vapors. Use of longer hose lengths is not recommended.

Parts List

See Parts List in Appendix A for a more complete list of replacement parts and accessories.

61-0123	Sensor, Combustible (LEL/PPM)
65-0613	Sensor, Oxygen (Fuel Vapor only)
80-0504	Hose, 3' teflon-lined
81-0007	Cylinder, 40% LEL Hexane
81-0078	Cylinder, 100% Nitrogen
81-0226-05	Cal kit, 40% LEL Hexane (Soil Vapor)
81-0226-06	Cal kit, 40% LEL Hexane/100% Nitrogen (Fuel Vapor)