

# Low Profile Air Strippers

## Geotech LO-PRO™

Geotech LO-PRO™ Models II and III are highly efficient water treatment systems that can remove up to 99.99% of many volatile organic compounds (VOCs) from water.

Systems are self-contained for use in limited space applications.

### FEATURES

- Patented multi-stage counterflow aeration provides up to 99.99% removal efficiency.
- Features vacuum induced draft design that is more efficient than forced draft and eliminates fluid leakage between trays.
- Low profile modular design requires less floor and head space.
- Lightweight modular polyethylene trays allows the addition or subtraction of trays to meet engineered treatment requirements.
- Stainless steel bubble plate design resists fouling.
- Highly effective on BTEX, MTBE, and Radon.
- Very easy to install and maintain.
- Remote monitoring and troubleshooting capability with the optional Geotech ECM.

### OPERATION

Contaminated water enters the Geotech LO-PRO™ at the top of the unit and cascades onto the first of a series of stainless steel bubble plates. A baffle in the center of each plate redirects the water 180° in each stage as it flows downward, alternating between clockwise and counter-clockwise directions. This action optimizes the residence time of the water in the Geotech LO-PRO™, allowing for efficient contaminant removal.



Geotech LO-PRO™ Model II

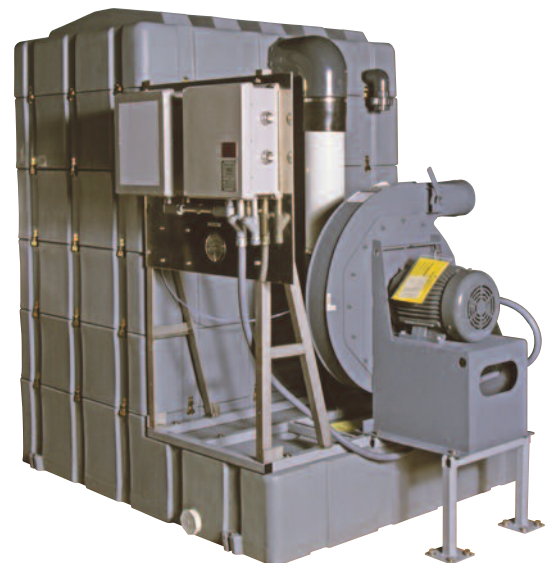

Geotech LO-PRO™ Model III S

**CALL GEOTECH TODAY (800) 833-7958**

**Geotech Environmental Equipment, Inc.**

2650 East 40th Avenue • Denver, Colorado 80205

(303) 320-4764 • **(800) 833-7958** • FAX (303) 322-7242

email: sales@geotechenv.com website: www.geotechenv.com

# Low Profile Air Strippers

## Geotech LO-PRO™

### KEY COMPONENTS OF THE LO-PRO

- 1 Lightweight polyethylene construction
- 2 Threaded coupling for easy assembly
- 3 Stainless steel bubble plates
- 4 Multi-stage counterflow aeration
- 5 Blower
- 6 Blower pressure gauge
- 7 Air inlet
- 8 Sump water level sensor
- 9 Hand operated latches

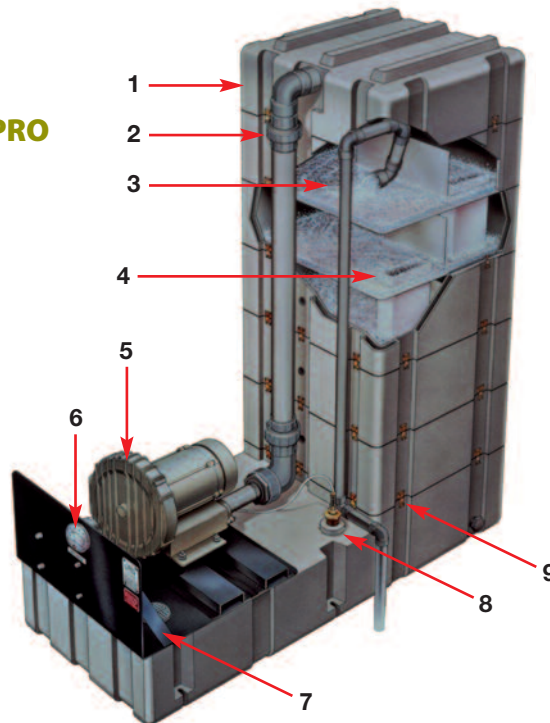

### SPECIFICATIONS

	LO-PRO Model II	LO-PRO Model III
<b>Applications:</b>	For use in non-classified and Class 1, Div. 2 locations	High flow-rate for use in non-classified and Class 1, Div. 2 locations
<b>Dimensions:</b>	5 tray unit: 66"L x 27"W x 75"H Each additional tray adds 10" to height	3 tray unit: 91"L x 60"W x 70"H Each additional tray adds 13" to height
<b>Maximum No. of Trays:</b>	8	5
<b>Material:</b>	Linear Low Density Polyethylene Housing Stainless steel bubble plates	Light Weight Polyethylene Housing Stainless steel bubble plates
<b>Water Flow:</b>	1-20 gpm (4-76 l/min)	1-60 gpm (4-227 l/min)
<b>Air Flow:</b>	Up to 250 CFM (7.1 CMM)	Up to 1100 CFM (31 CMM)
<b>Blower HP:</b>	1-5 HP regenerative blower (TEFC: for use in Class 1, Div. 2 locations)	10-15 HP centrifugal blower (TEFC: for use in Class 1, Div. 2 locations)
<b>Blower Voltage:</b>	208-230/460V, 50 Hz or 60 Hz, 3 phase Single phase available	208-230/460V, 50 Hz or 60 Hz, 3 phase
<b>Options:</b>	High pressure switch assembly, low pressure switch assembly, Geotech ECM controls and telemetry, motor starter package, sump water level sensor, additional trays, CFM gauge and valve assembly, transfer pumps. Explosion-proof blower.	High pressure switch assembly, low pressure switch assembly, Geotech ECM controls and telemetry, motor starter package, sump water level sensor, additional trays, CFM gauge and valve assembly, transfer pumps. Explosion-proof blower.

**CALL GEOTECH TODAY (800) 833-7958**

**Geotech Environmental Equipment, Inc.**

2650 East 40th Avenue • Denver, Colorado 80205  
 (303) 320-4764 • **(800) 833-7958** • FAX (303) 322-7242  
 email: sales@geotechenv.com website: www.geotechenv.com