

Q-RAE PLUS

PGM-2000/2020

MULTI-GAS MONITOR



SHORT FORM

OPERATION & MAINTENANCE

MANUAL

Document Number: 015-4011-000
Revision B, April 2005



*** READ BEFORE OPERATING ***

The instrument manual must be carefully read by **all** individuals who have responsibility for using, maintaining, or servicing this product. The product will perform as designed only if it is used, maintained, and serviced in accordance with the manufacturer's instructions.

THIS IS A SHORT FORM OF THE MANUAL – THE COMPLETE MANUAL WITH ALL OPERATION AND MAINTENANCE INSTRUCTIONS IS CONTAINED ON THE CD-ROM SHIPPED WITH THIS PRODUCT

CAUTION!

To reduce the risk of electric shock, turn off power before removing the monitor cover. Disconnect the battery before removing sensor modules for service. Never operate this monitor while the cover is removed. Remove monitor cover and sensor modules only in an area known to be non-hazardous.

ATTENTION!

For European Applications

- A. CE 0575  II 2G
DEMKO 02 ATEX 04201X
EEx ia d IIC T4 (with Battery Pack P/N 015-3052)
EEx ia d IIC T3 (with Battery Pack P/N 015-3053)
- B. Recharge batteries only in non-hazardous locations
- C. Do not connect external cable to serial interface jack in hazardous locations.
- D. Use RAE Systems Adapter P/N 500-0072 for connection to communication port and charging jack only in a non-hazardous area.

SPECIAL NOTE

When the QRAE Plus multi-gas monitor is taken out of the transport case and is turned on for the first time, there may be some residual vapors trapped inside the monitor and the initial toxic gas sensors may indicate a few ppm. After running the monitor for several minutes in clean air, the residual vapors should clear and readings should return to near zero.

WARNINGS!

For safety reasons this equipment must be operated and serviced by qualified personnel only. Read and understand the instruction manual completely before operating or servicing.

Use only RAE Systems battery packs, part number 015-305, 015-3052, or 015-3053. *Battery pack 015-3051 is not approved for use in Europe. This instrument has not been tested in an explosive gas/air atmosphere having an oxygen concentration greater than 21%. Substitution of components may impair intrinsic safety. Recharge batteries only in non-hazardous locations.

Do not connect external cable to serial interface jack in hazardous locations.

STATIC HAZARD

Clean only with a damp cloth.

CALIBRATION

The calibration of all newly purchased RAE Systems Instruments should be tested by exposing it to known concentration calibration gases before the instrument is put into service for the first time.

For safety, check the accuracy of the QRAE Plus by exposing the sensors to known concentration calibration gas before each day's use.

READINGS

Any rapid up-scale reading followed by a declining or erratic reading may indicate a gas concentration beyond upper scale limit, which may be hazardous.

AVERTISSEMENTS!

Pour des raisons de sécurité, cet équipement doit être utilisé, entretenu et réparé uniquement par un personnel qualifié. Étudier le manuel d'instructions en entier avant d'utiliser, d'entretenir ou de réparer l'équipement.

Utiliser seulement l'ensemble de batterie RAE Systems avec numéro de série 015-3051, 015-3052, ou 015-3053. *Le batterie avec numéro de série 015-3051 est interdit pour usage en Europe. Cet instrument n'a pas été essayé dans une atmosphère de gaz/air explosive ayant une concentration d'oxygène plus élevée que 21%. La substitution de composants peut compromettre la sécurité intrinsèque. Ne charger les batteries que dans l'emplacements désignés non-dangereux.

Connectez pas le cable externe au port parallel dans un environnement non-dangereux.

DANGER RISQUE D'ORIGINE ELECTROSTATIQUE

Nettoyer uniquement avec un chiffon humide.

LA CALIBRATION

La calibration de toute instruments de RAE Systems doivent être testé en exposant l'instrument a une concentration de gaz connue par une procédure dietalonnage avant de mettre en service l'instrument pour la première fois.

Pour une securite maximale, la sensibilité du QRAE Plus doit être verifier en exposant l'instrument a une concentration de gaz connue par une procédure dietalonnage avant chaque utilisation journalière.

LES LECTURES

Toute lecture rapide et positive, suivie d'une baisse subite au erratique de la valeur, peut indiquer une concentration de gaz hors gamme de détection qui peut être dangereuse.

1. General Information

The Q-RAE Plus is a programmable multi-gas monitor designed to provide continuous exposure monitoring of toxic gases, oxygen and combustible gases for workers in hazardous environments. There are two models available: **PGM-2000**, a pumped unit, and **PGM-2020**, a diffusion unit.

Table 1. QRAE Plus Specifications

Dimensions:	3" L x 4.5" W x 1.8" H (7.6 x 11.4 x 4.3 cm)
Weight:	15 oz (525 g) with battery
Detectors:	2 Electrochemical toxic gases sensors 1 Electrochemical oxygen sensor 1 Catalytic/Thermal conductivity sensor for combustibles
Battery:	Rechargeable 3.6V/3000 mAh, Li-ion battery pack with built-in charger – 8 hours of charge time, up to 20 hours run time Alkaline battery adapter (2 AA's)
Operating Time:	Up to 20 hours continuous w/ Li-ion battery pack
Display:	Two-line, 16-character LCD with automatic LED backlight for dim lighting conditions
Keypad:	One operation key. 2 programming keys
Direct Readout:	Up to 4 instantaneous values, sensor name, high and low values for all sensors, TWA and STEL values for toxic, battery voltage and elapsed time
Sampling Pump:	Internal integrated pump with adjustable settings for low or high speed sampling
Alarm Settings:	Separate limits for TWA, STEL, low and high
Alarms:	95 dB buzzer, flashing red LED, vibration alarm, LCD to indicate exceeded preset limits, low battery, or sensor failure
Calibration:	Two-point field calibration for fresh air and standard reference gas Three-point optional oxygen calibration
Attachments:	Rubber boot, belt clip, wrist strap
Protection:	Password protected calibration settings, alarm limits, and data

GENERAL INFORMATION

(Continued)

Intrinsic Safety: UL Class I, Division I, Groups A, B, C, D, and Class II, Division I, Groups E, F, G

(Europe)

CE 0575  II 2G

DEMKO 02 ATEX 04201X

EEx ia d IIC T4 (with Battery P/N 015-3052)

EEx ia d IIC T3 (with Battery P/N 015-3053)

EM Immunity: No effect when exposed to 0.43mW/cm² RF interference (5 watts at 12")

Data Storage: 16,000 points of non-volatile memory (up to 67 hrs of reading 4 sensors at one-min. intervals)

Datalog Interval: Programmable 1- to 36,000-second intervals

External Alarm: Optional, plug-in, pen-size vibration alarm

External Printer: Optional, plug-in, thermal serial printer

Communication: Download data to PC

Upload monitor setup from PC through an RS-232 link to serial port on PC

Temperature: -20°C to 45°C (-4°F to 113°F)

Humidity: 0% to 95% relative humidity (non-condensing)

Table 2. Range, Resolution & Response Time
(t₉₀ for pump-equipped instruments)

Sensor	Range	Resolut.	t ₉₀ (Sec)	Presoak time for 60-s Cal.
LEL	0-100% LEL	1%	15	0 Seconds
VOL	0-100% Vol	1%	20	0 Seconds
O ₂	0-30%	0.1%	15	0 Seconds
CO	0-500 ppm	1.0 ppm	40	0 Seconds
H ₂ S	0-100 ppm	1.0 ppm	35	0 Seconds
SO ₂	0-20 ppm	0.1 ppm	35	0 Seconds
NO	0-250 ppm	1.0 ppm	30	0 Seconds
NO ₂	0-20 ppm	0.1 ppm	25	0 Seconds
Cl ₂	0-50 ppm	0.1 ppm	60	60 Seconds
PH ₃	0-5 ppm	0.1 ppm	60	60 Seconds
NH ₃	0-50 ppm	1.0 ppm	150	90 Seconds
HCN	0-100 ppm	1.0 ppm	200	170 Seconds

2. Operation

2.1. Physical Description

Main components of the Q-RAE Plus multi-gas monitor:

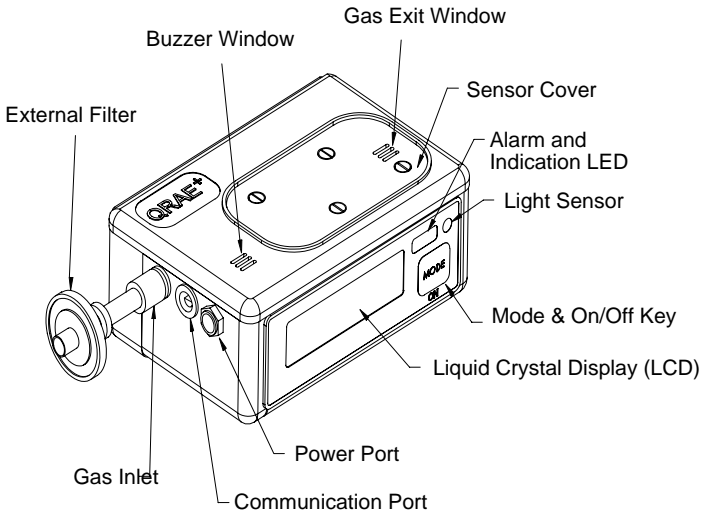

Figure 1. Front View of the Q-RAE Plus

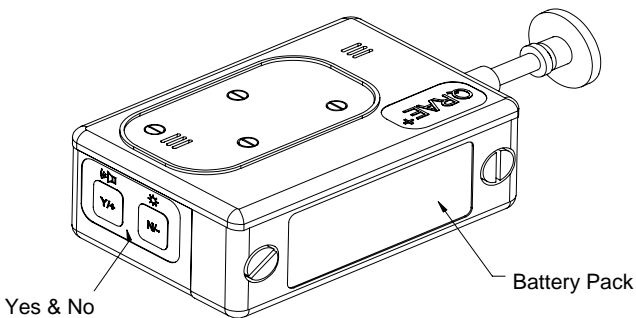

Figure 2. Back View of the Q-RAE Plus

2.2. Operation of Monitor

The functions of the three keys are summarized below.

Table 3. Key Functions

- [MODE]** Hold for 1 second and release to turn ON; hold for 5 seconds to turn OFF; toggle to different displays. Exit program menu tier; exit data entry mode when held for 1 second
- [N/-]** Answer “No” to a question; decrease a number; toggle the backlight on & off.
- [Y/+]** Answer “Yes” to a question; increase a number; test alarm; alarm condition acknowledgment

The Q-RAE Plus monitor has two operation modes:

1. Basic mode is the simplest mode of operation. The monitor alternately displays the instantaneous concentration readings and the sensor names after the monitor is turned on. The user can press the **[MODE]** key to see critical data, battery voltage or enter the PC communication mode. The displays in the main loop of the Basic mode are shown in Figure 3.

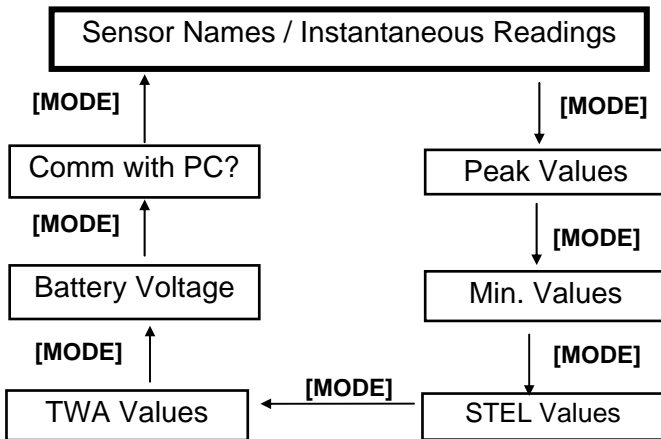
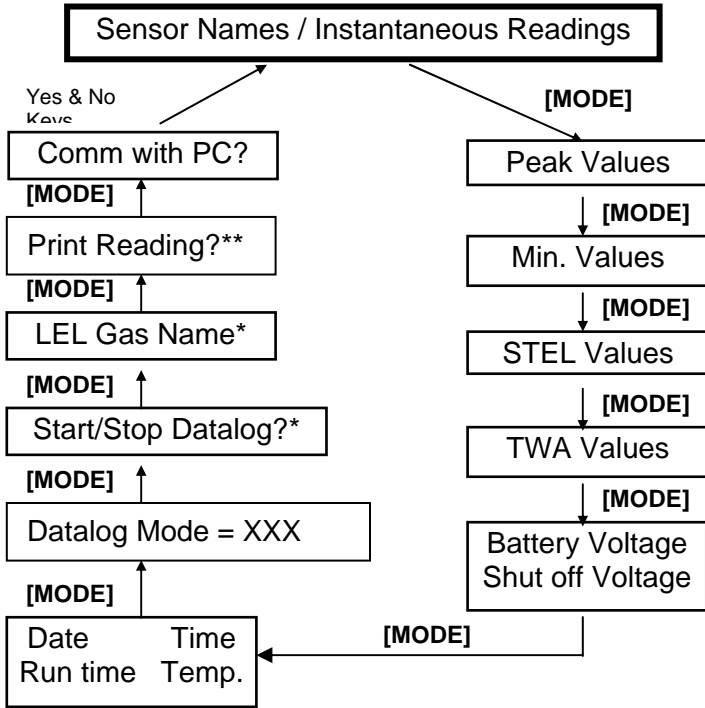

Figure 3. Displays in Basic Mode

2. Advanced mode, shown schematically in Figure 4, displays more information than the Basic mode and allows access to more programming functions. The Programming Mode is explained in detail in Chapter 4 of the long form manual.



* Datalog appears only when unit has datalogging option and is programmed in manual datalog mode. LEL gas appears only when LEL sensor is installed. ** Print Reading appears only if this option is enabled through ProRAE Suite software.

Figure 4. Displays in Advanced Mode

To choose a specific display, press **[MODE]** one or more times until the desired display appears. An “OK!” mark means the unit is in Basic mode and no alarm condition exists. A small “L” means the unit is logging data. Press **[Y/+]** to perform the function of any question displayed.

2.3. Alarm Signals

The Q-RAE Plus will alarm under conditions summarized in Table 4.

Table 4. Alarm Signals and Reset			
Condition	Alarm Signal	Message	Alarm Reset by
Gas exceeds "High Alarm" limit	3 beeps/flashes per sec/ Vibration	Sensor name and "High"	Move away from gas.
Gas exceeds "Low Alarm" limit	2 beeps/flashes per sec/ Vibration	Sensor name and "Low"	Move away from gas.
Gas exceeds STEL	1 beep/flash per sec / Vibration	Sensor name and "STEL"	Move away from gas and wait 15 minutes.
Gas exceeds TWA	1 beep/flash per sec / Vibration	Sensor name and "TWA"	Move away from gas, turn unit OFF and ON
Gas exceeds the sensor range	3 beeps/flashes per sec/ Vibration	Sensor name and "OVR"	Move away from gas.
Unit short circuit or reading over maximum range	3 beeps/flashes per sec/ Vibration	Sensor name and "MAX"	Move away from gas.
Excessive sensor negative drifting	1 beep/flash per sec / Vibration	Sensor name and "NEG"	Perform a fresh-air zero calibration.
Blocked inlet or pump failure	3 beeps/flashes per sec	"Pump"	Unblock the inlet and press [Y/+]; adjust pump threshold.
Excessive LEL gas or LEL sensor OFF	3 beeps/flashes per sec/ Vibration	LEL sensor name and "Off"	Move away from gas and turn the LEL sensor back ON.
Low battery (<3.3V)	1 flash per sec 1 beep per min	"Bat"	Charge the battery.
Memory full	1 flash per sec	"Mem"	Clear the datalog.
Datalog memory write error	1 flash per sec	"Emm"	Turn the unit OFF and then back ON.

Alarm Signal Testing: Under normal non-alarm conditions, the buzzer, vibration alarm, LED, and backlight can be tested by pressing [Y/+] momentarily.



The alarm signals are disabled during PC communication, calibration, and datalog review or when printing to a serial printer. To reduce the risk of exposure to hazardous atmospheres, perform these operations only in areas known to be safe. During these operations, real time monitoring of the gas stops.

 **WARNING!** 

The QRAE Plus, portable gas detector has been designed for the detection of oxygen deficiencies, flammable gas, and toxic vapor levels. An alarm condition indicating the presence of one or more of these potentially life-threatening hazards should be taken very seriously.

In the event of an alarm condition it is important to follow established procedures. The safest course of action is to immediately leave the affected area, and return only after further testing together with other appropriate safety procedures to determine that the area is once again safe for entry.

2.4. Datalogging

This function applies only to datalogging monitors.

The Q-RAE Plus multi-gas monitor calculates and stores the gas readings based on a user-specified datalogging period and the type of measurement. Both average and peak values can be stored for each sensor during each datalogging interval. The datalogging interval can be programmed from one second to 60 minutes. In addition, time stamp, user ID, site ID, serial number, last calibration date, and alarm limits are also stored. All data are retained in non-volatile memory for later download to a PC. There are four options to start/stop datalog operation:

- **Automatic:** start and stop datalogging automatically when the monitor is turned on or off.
- **Manual:** start and stop datalogging in user mode manually.
- **Periodic:** start and stop datalogging daily, based on preset start and stop time (hour and minute).
- **Scheduled:** start and stop datalogging one time at a preset start and stop date and time.

If manual datalog mode has been selected, start and stop datalogging using the keystrokes in Table 4. The other three datalog options will start and stop automatically without any user intervention.

3. Programming & Calibration

The Q-RAE PLUS monitor is built with a microcomputer to provide programming flexibility for a variety of users. Authorized users can calibrate the monitor, change the measurement gas, change the alarm limits, change site ID, user ID, datalogging interval, real time clock, etc.

Note: The real time monitoring of gas concentrations continues while in the programming mode. However, during calibration or review datalog procedures, real time monitoring pauses until the procedures are completed. Datalogging also pauses automatically upon entering programming mode and resumes upon exiting.

3.1. Programming Mode

To enter the programming mode, hold down the **[MODE]** and **[N/-]** keys simultaneously for three seconds. To exit this mode, press **[MODE]** repeatedly until the main concentration display shows.

There are also three security levels to control the access of the Q-RAE Plus programming mode.

- “Level 2” security (factory default) offers complete access to the programming menus without a password.
- “Level 1” security requires a 4-digit password to enter programming menus. The Factory default is “0000”.
- “Level 0” security does not require a password, but offers only limited access to the programming menus.

In Basic mode, calibration is available but modification of the other monitor settings is limited. Refer to Appendix A of the Long Form Manual for a table of the detailed accessibility to the programming functions.

The programming functions are organized in a multiple tier menu structure. The main programming menu in advanced mode is shown below:

Table 5. Programming Menus

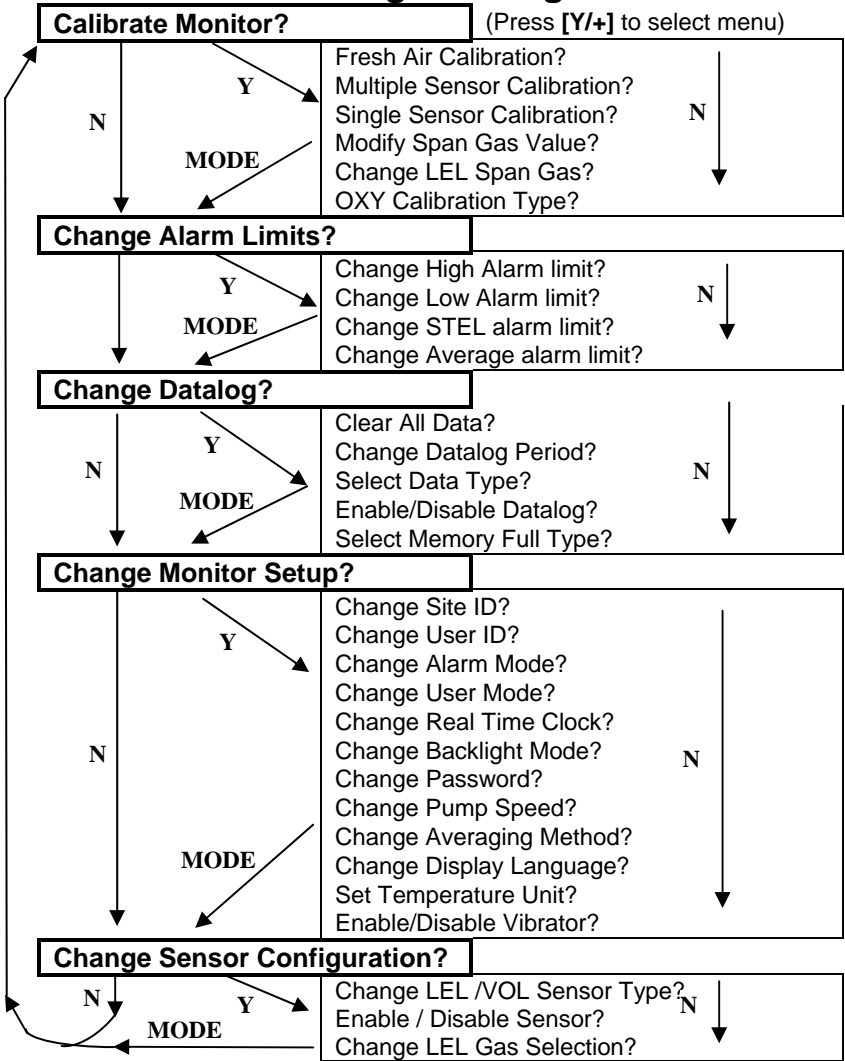

Press [Y/+] to enter any submenu. Press [N/-] skip to the next menu or [MODE] to move up one level. To edit values or select sensors, a flashing digit should appear that can be increased or decreased using the [Y/+] or [N/-] key. Then

press **[MODE]** to move to the next digit or sensor, and hold down **[MODE]** to exit and save any changes.

3.2. Calibration



The calibration of all newly purchased RAE Systems instruments should be tested by exposing the sensor(s) to known concentration calibration gas(es) before the instrument is put into service the first time.

For maximum safety, the accuracy of the QRAE PLUS should be checked by exposing the sensor(s) to known concentration calibration gas(es) before each day's use.

Pumped Instruments

Pumped monitors are preferably calibrated with gas at atmospheric pressure, such as with flowing gas in an open or "Tee", or from a Tedlar gas bag. Alternately, to save gas, connect the monitor directly to the gas bottle using a demand-flow regulator. Direct connection to a cylinder with fixed-flow regulator at 0.5 - 1.0 liters per minute is less accurate than the other methods by a few percent.

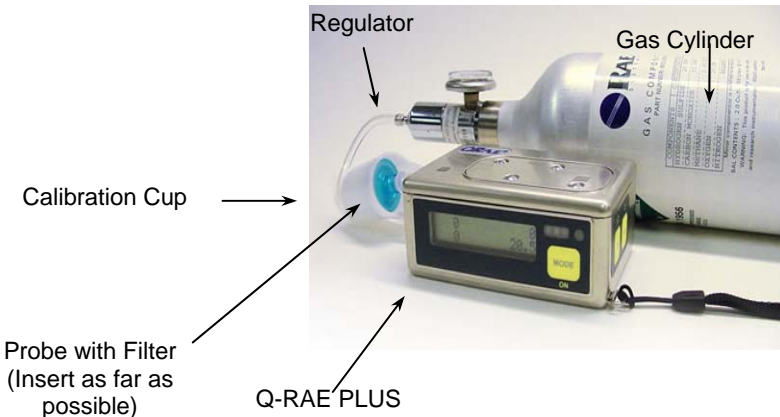

Figure 5. Calibration Connection

Diffusion Instruments

Q-RAE Plus diffusion monitors must be calibrated using a fixed flow regulator with a flow rate between 0.5 and 1.0 liters per minute. Diffusion monitors are supplied with a special calibration adapter that covers the gas diffusion port.

Sensor Calibration Time

Slowly responding sensors listed in Table 2 may require pre-exposure of the sensor to the gas immediately before initiating the calibration sequence. Some firmware versions use a fixed 60-second calibration time; some newer versions automatically apply the full calibration time. After completing the zero calibration, expose the unit to the gas for the pre-exposure time listed in Table 2 if a 60-second countdown time is programmed in the unit.

If the firmware has the full calibration time programmed in, the sensors must be calibrated in the Single Sensor mode to take advantage of this feature. The calibration time is set at 60 seconds in the Multiple Sensor mode and may not be changed.

3.2.1. Zero (Fresh Air) Calibration

This procedure determines the zero point of the sensor calibration curve. Expose the inlet to a clean air source with 20.9% oxygen and without any organic, toxic or combustible gas impurities. This “Zero Air” can be from a cylinder, clean ambient air, or ambient air purified through a charcoal filter.

Initiate “Fresh Air Calibration?” using the keystrokes in Table 5. When the zero calibration is successful, the display should show a reading of “20.9” for the oxygen sensor and “0.0,” or a very small number, for all other sensors.

3.2.2. Multiple Sensor Calibration

This function simultaneously determines the second point of the calibration curve for multiple sensors in the monitor. For slowly responding sensors, preapply the gas for the times shown in Table 2. Initiate Multiple Sensor Calibration according

to Table 5 and then apply a source of mixed standard reference gases*. The display will count down from 60 to 0 seconds, and then show the name of each sensor, the message “cal’ed!” and the calibrated value for each gas. The readings should be very close to the span gas values.

To select other sensors to calibrate, press **[N/-]** after entering Multiple Sensor Calibration. The display shows all the sensors selected for multiple sensor calibration with the cursor blinking at the first sensor location. Press **[Y/+]** or **[N/-]** to select or de-select a sensor as indicated by an asterisk “*”.

CO*	----	H ₂ S*
LEL*	pick	OXY

Note: Oxygen span calibration is normally done during fresh air zero, so oxygen is not selected in this multi-gas calibration. See Single Gas Calibration to calibrate the oxygen sensor.

* **Cross Sensitivity:** some sensors show cross sensitivity to other gases; therefore, it is important to choose the gas mixture carefully to avoid erroneous calibration due to cross sensitivity. For example, H₂ and some organic gases are known to cause a response on the CO sensor, and H₂S responds on the NH₃ sensor.

3.2.3. Single Sensor Calibration

This procedure determines the second point of the sensor calibration curve for a single sensor. Enter Single Sensor Calibration according to Table 5 and press **[MODE]** to select the desired sensor. Preapply the gas for the times shown in Table 2 (if necessary) and press **[Y/+]** to initiate calibration.

Oxygen Sensor Calibration

The O₂ sensor allows 2-point or 3-point calibration type. The 3-point calibration gives greater accuracy for oxygen near 19.5%, a common alarm limit for warning of oxygen depletion. First set this type in Section 3.2.6. Span calibration at 20.9% O₂ is

performed during Fresh Air Zero. Low O₂ calibration at 0% or 19.5% O₂, or both, is done in Single Sensor calibration mode. Upon selecting OXY for Single Sensor calibration (see above) press **[N/-]** for 0% O₂ calibration or **[Y/+]** for 19.5% calibration. To perform both calibrations in the 3-point mode, the single sensor calibration must be re-entered after the first calibration is complete.

Calibration Time Stamp

Whenever span calibration is performed, a time stamp is stored in the non-volatile memory to be included in datalog reports.

3.2.4. Modify Span Gas Value

Use the keystroke procedures in Table 5 to change the concentration of the span gases used for calibration.

The span value for oxygen is 19.5% and can be changed between 19.0% to 20.0%. This value is only used if the monitor is set to 3-point oxygen calibration (see Section 3.2.6 and Section 3.2.3 for more details).

3.2.5. Change LEL Span Gas

This function allows selection of the gas to be used for span calibration of the LEL sensor. The correction factor for the measurement gas is automatically divided by the correction factor for the span gas selected here, to obtain a new factor for the combination of gases. The new factor will be applied to the readings to obtain a true concentration.

Enter the Change Span Gas menu using the keystroke procedures in Table 5. When the question "LEL Span = ? Methane" appears, press **[N/-]** to change the gas and then use the **[Y/+]** and **[N/-]** keys to scroll through a list of gas names until the desired gas appears. Press **[MODE]** to save the selected gas.

3.2.6. OXY Calibration Type

Select 2-point or 3-point O₂ sensor calibration type using the keystroke procedures in Table 5.

3.3. Change Alarm Limits

Alarm limits can be changed using the keystrokes in Table 5. The average type can be set to either “Running Average” or “Time Weight Average” (TWA) under the “Change Averaging Method?” sub-menu of the “Change Monitor Setup?” menu

3.4. Change Datalog

Datalog parameters can be modified using the keystrokes in Table 5. Additional datalog options can be programmed using a PC and downloaded to the monitor (see ProRAE Suite Manual for details). Datalog options include:

1. “Clear All Data?” clears all the stored data.
2. “Change Datalog Period?” the interval between stored measurements can be set from 1 to 3,600 seconds.
3. “Select Data Type?” A choice of peak or average reading in the datalog period will be stored.
4. “Enable / Disable Datalog?” activates or suspends the datalog function, as indicated by an asterisk (*) next to an enabled sensor’s name.
5. “Select memory full type?” allows a choice of “wrap around,” overwriting the oldest data, or “Stop” storing data when memory is full.

3.5. Change Monitor Setup

1. **Site ID** – An 8 digit alphanumeric location identifier to be included on datalog reports.
2. **User ID** – An 8 digit alphanumeric user identifier to be included on datalog reports.
3. **Alarm Mode** – Determines whether the alarm will latch or automatically reset after an alarm situation occurs.
4. **User Mode** – Basic or Advanced Mode controls access to programming menus, information and security levels.

5. **Real Time Clock** – Adjustable date “Feb 07, ‘00” and time “hh:mm” Included on datalog reports.
6. **Backlight Mode** – Manual or automatic. If manual mode is chosen, pressing the **[N/-]** key will turn on the LCD backlight. Automatic mode allows the backlight to turn on when the ambient light falls below a threshold level preset in the monitor.
7. **Password** – A 4-digit numeric character which allows the user to enter the programming mode when needed. The manufacturer’s default password is “0000.”
8. **Pump Speed** – Low or high. The factory default setting is low, which reduces the flow rate by 30%, but increases the battery run time by 10%, and increases the lifetime of the LEL sensor. High speed offers quicker response time. High pump speed is preferred for reactive and slowly-responding gases such as Cl₂, PH₃, NH₃, and HCN.
9. **Averaging Method** – (TWA) Time Weighted Average (*default*) or (AVG), the running average.
10. **Change Display Language** – Select Spanish or English
11. **Temperature Units** – Select Centigrade or Fahrenheit.
12. **Enable/Disable Vibrator** – activate or deactivate the vibration alarm.

3.6. Change Sensor Configuration

This function allows the user to change LEL/VOL Sensor type, change LEL measurement gas, and enable or disable sensors.

Correction Factors

The LEL sensor used in Q-RAE Plus responds to a broad range of gases having different sensitivities. A correction factor can be multiplied by the apparent reading to give the true gas concentration:

True Concentration = Correction Factor x Monitor Reading

Correction factors allow measurement of a specific gas while using a different gas for calibration.

The Q-RAE Plus stores several different correction factors for the LEL sensor in a compound library that can be accessed through the Change LEL Span Gas and Change LEL Gas Selection Menus.

Note: Using the correction factor provides an estimate the target measurement gas. For greatest accuracy, it is necessary to calibrate the LEL sensor directly with the target gas.

3.6.1. Change LEL/VOL Sensor Type

Note: Combination LEL / VOL Sensor is not available in North America.

This programming sub-menu applies only to monitors with the combination LEL/VOL sensor installed. This sensor can be setup to measure combustible gases by percentage of the Lower Explosive Limit (LEL), or it can be set up to measure a variety of gases in percent by volume (VOL) levels up to 100%. The sensor can be set up to automatically switch from %LEL to %VOL when methane is selected for both sensors. Use the Keystrokes from Table 5 to switch between LEL, VOL, and Auto-ranging modes.



Auto-range should be selected only when the methane is used as the calibration and target gas.
--

3.6.2. Enable / Disable Sensor

This function allows the user to selectively enable or disable individual sensors in the Q-RAE Plus monitor. When a sensor is disabled, the unit will not datalog or display gas concentrations of that type. Use the keystrokes in Table 5 to

select or de-select the desired sensors, as indicated by an asterisk (*) next to all enabled sensor names.

3.6.3. Change LEL Gas Selection

This function allows selection of the measurement gas for the LEL sensor. The correction factor for this gas is automatically be divided by the correction factor for the span gas selected previously, to obtain a new factor for the combination of gases. The new factor is applied to the readings to obtain a true concentration.

Enter the Change LEL Gas menu using the keystroke procedures in Table 5. When the question “LEL Gas = ? Methane” appears, press **[N/-]** to change the gas and then use the **[Y/+]** and **[N/-]** keys to scroll through a library of gas names until the desired gas appears. Press **[MODE]** to save the selected gas. The monitor then prompts the user to modify the correction factor if it is incorrect. If the desired gas is not in the library, custom correction factor can be selected from the list and then the factor adjusted. See the Long Form Manual for complete procedures.

4. Maintenance

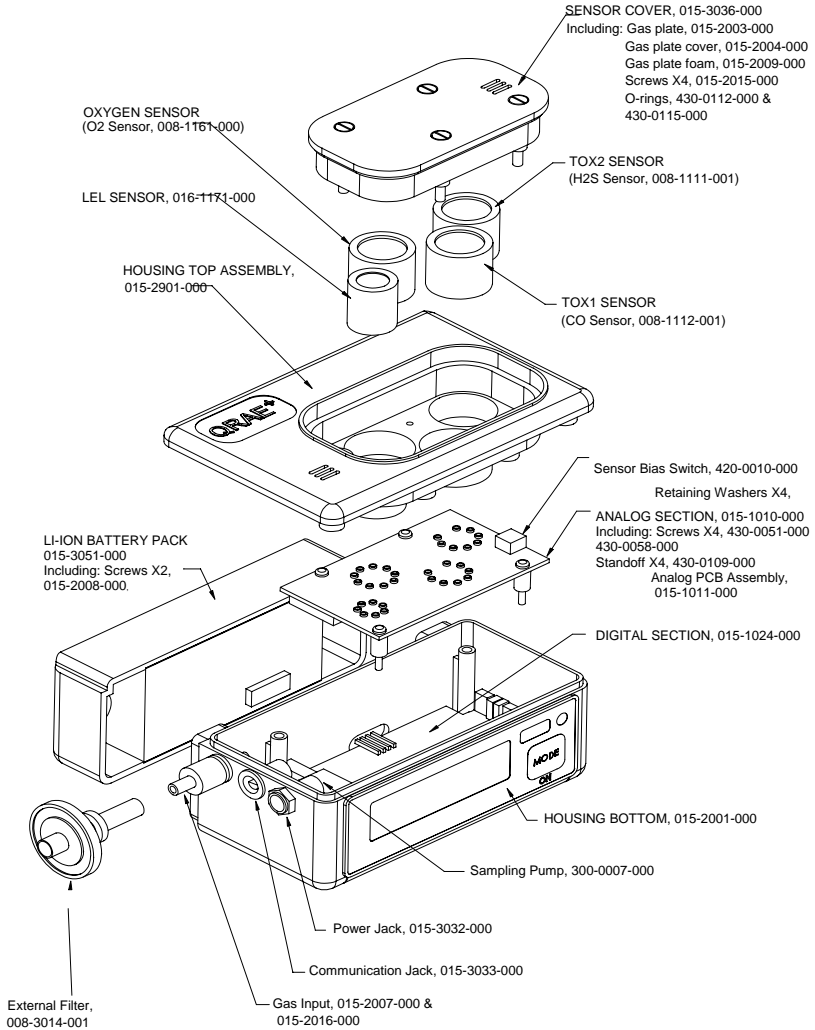

Figure 6. Main Components of Q-RAE PLUS

 **WARNING!** 

Maintenance should be performed only by a qualified person who has proper training and fully understands the contents of this manual.

The following guidelines should be followed when changing components:

1. Turn off the unit and unplug the charger before changing a battery. The battery pack screws can be tightened or loosened using a coin.
2. When changing a sensor, detach the battery first and then open the sensor cover only, not the housing top.
3. Identify the location of a specific sensor and pay attention to the sensor pin orientation when removing and plugging in sensors.
4. The NO and NH₃ sensors require a special 300 mV bias voltage to operate. A “dip switch” located on the PCB next to the Tox 1 and 2 sensor positions must be placed in the “ON” position for the corresponding sensor to enable the bias voltage when an NO or NH₃ sensor is installed. The default setting of bias OFF is used for most sensors.

4.1. Battery Charging Operation

 **WARNING!** 

To reduce the risk of ignition of hazardous atmospheres, recharge battery only in area known to be non-hazardous. Remove and replace battery only in area known to be non-hazardous.

Ne charger les batteries que dans l'emplacements désignés non-dangereux.

The charging circuit of the Q-RAE Plus is built into the monitor. Plug the AC to 12 V DC wall mount transformer adapter (or the automotive charging adapter) into the power source and connect the power jack to the monitor. The charging LED should be red during charging and green when fully charged. Smart charging circuitry protects the battery from overcharge, so removing the charger is not required.

Note: For European markets, Adapter P/N 500-0072 is required.

The battery drains slowly even if the monitor is turned off. After about 25 days, the battery voltage will be low.

4.2. Alkaline Battery Adapter

The AA Alkaline battery adapter supplied by RAE Systems is intrinsically safe!

An alkaline battery adapter accepts two AA batteries and can be used in place of the Li-ion battery pack, as shown below, to provide approximately 6 hours of operation, when there is no time to charge the Li-ion battery pack.

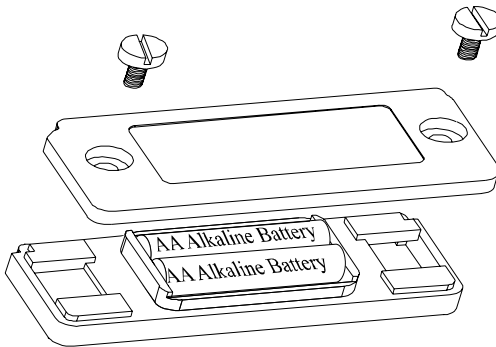

Figure 7. Alkaline Battery Adapter

The internal charging circuit of Q-RAE Plus will automatically detect the alkaline battery adapter and prevent the charging of alkaline batteries.

NOTE: The monitor draws power from the battery pack even when turned off. Severe damage to the circuit board may occur if the battery pack is not disconnected before servicing the unit or replacing sensors or any other components inside.

4.3. External Filter

The external filter is made of PTFE (Teflon[®]) membrane with a 0.2 micron pore size to prevent water and dust from being sucked into the sensor manifold, and to prolong the operating life of the sensors and pump. The external filter should be replaced if it changes color, traps dust or other particulates, or if water has been sucked into it.

For faster response, the user may consider removing the external filter for some reactive gases including Cl₂, PH₃, NH₃, and HCN. However, doing so may shorten the pump and sensor lives.

5. Troubleshooting Tips

To aid diagnosis of the monitor, it has a diagnostic mode that displays critical, low level parameters. Section 5.1 describes the diagnostic mode. Section 5.2 summarizes the frequently encountered problems and suggested solutions.

Turning the Q-RAE Plus monitor on in diagnostic mode, and using the troubleshooting table in section 5.2, the user can narrow problems down to one or two areas and often correct the problem without having to return the monitor for repair.



The diagnostic mode allows the user to set several low-level parameters that are critical to monitor operation. Extra care should be taken when setting these low-level parameters. If the user is not familiar with these parameters and sets them incorrectly, it may cause the monitor to malfunction.

5.1. Diagnostic Mode

To place the monitor in diagnostic mode, first turn the monitor off. Next push and hold the **[Y/+]** and the **[MODE]** keys for at least two seconds. After the unit “beeps”, release both keys and the monitor will turn on in diagnostic mode and will show 1 to 4 numbers with a message “Raw”. These numbers are the raw sensor readings without calculation. If the raw reading is outside the normal range, or does not change when gas is applied, the sensor or the unit may be defective.

Other parameters of the monitor can be reached by pressing **[MODE]** repeatedly until the desired parameter is shown. See the long form manual for details of each parameter function.

Table 6. Displays in Diagnostic Mode	
Key Action	Display
	Sensor raw readings
[MODE]	sensor name
[MODE]	battery voltage, & charge raw count
[MODE]	Adjust LCD contrast
[MODE]	Adjust buzzer frequency
[MODE]	LEL or VOL sensor raw readings
[MODE]	Date, time, battery voltage & temperature
[MODE]	LEL & OXY sensor expiration date
[MODE]	Tox1 & Tox2 sensor expiration date
[MODE]	Adjust pump stall threshold
[MODE]	Serial number
[MODE]	Battery duration time
[MODE]	Communicate with PC?

5.2. Troubleshooting Tips

Problem	Possible Cause	Possible Solution
Cannot turn on power after charging battery	Defective battery. Microcomputer hang-up.	Charge or replace battery. Disconnect then connect battery to reset computer.
No LED or LCD backlight	Wrong mode setting. Defective LED or LCD backlight.	Check and see if the backlight is in automatic or manual mode. Call service center.
Lost password	Forgot.	Use ProRAE Suite to reset the password.
Buzzer inoperative	Bad buzzer	Call authorized service center.
Calibration error message	No standard gas input Low sensitivity to cal gas	Check standard gas flow path or cylinder pressure Change cal gas or sensor
“Voltage too high” message	Battery fuse blown or wrong AC adapter	Check battery and adapter.
“Bat”message	Battery Low	Recharge battery.
High pump noise or no inlet suction	Leaky inlet path Defective pump	Check inlet connection. Replace pump.
Abnormally low reading	Incorrect calibration or calibration error	Make sure the span gas value matches the calibration gas, then re-calibrate.
Reading jumping around	Incorrect gas calibration Low sensitivity to cal gas	Calibrate the sensor. Use different cal gas. Change sensor.
Cannot turn off monitor or corrupted characters	Microprocessor hang-up	Disconnect and re-connect battery to reset computer. Reload the firmware.
Read a small background value	There is actually a small background gas level Sensor zero drift	Do fresh air calibration

RAE Systems, Inc., Main Office

3775 N. First St.
San Jose, CA 95134 -1708

Contact Numbers

Telephone
408.952.8200

Fax
408.952.8480

Instrument Sales
877.RAE.CUSTOMER
(877.723.2878)

Tubes Sales
888.RAE.TUBE
(888.723.8823)

Technical Support
888.723.4800

E-mail

RaeSales@raesystems.com
Tech@raesystems.com

Website

www.raesystems.com
