

# Wavelet Ex V2

WA3888-xx-V2

EXPLOSIVE ENVIRONMENT

QUICK START

GUIDE

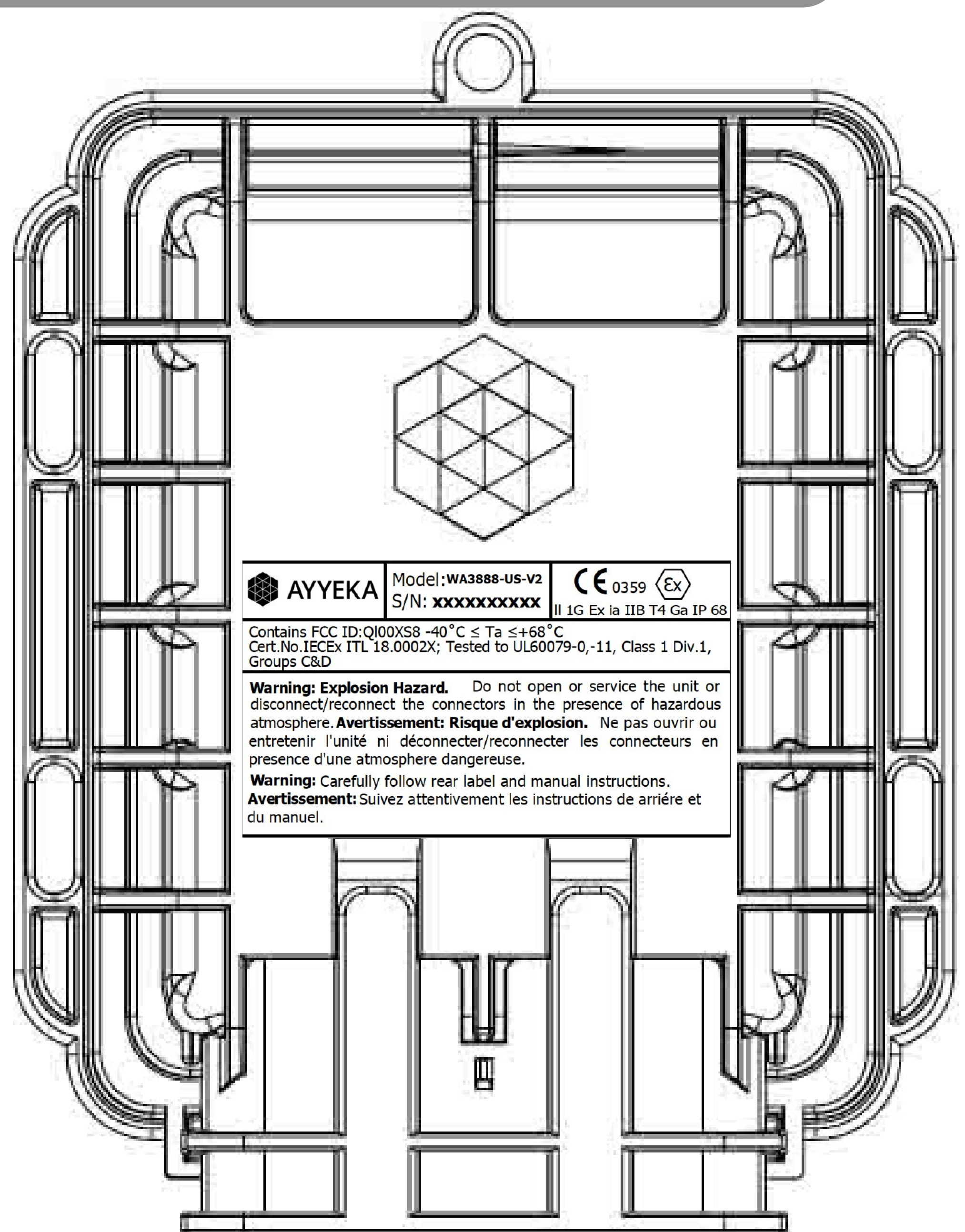
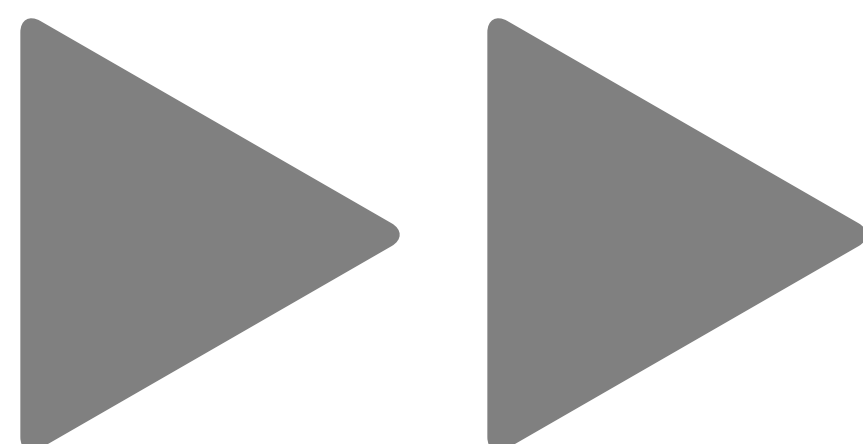

CALL GEOTECH TODAY

(800) 833-7958

Geotech Environmental Equipment, Inc.  
2650 East 40th Avenue • Denver, Colorado 80205  
(303) 320-4764 • FAX (303) 322-7242

email: sales@geotechenv.com • website: www.geotechenv.com

Feb 19, 2023

0100592 Rev 4



It is important that you read the QuickStart Guide in a controlled environment prior to installation.

Set up, activate, and successfully test the entire system (Wavelet Ex, sensors, and antenna connection) indoors, in a controlled environment, before going to the field for installation.



Model:  
**WA3888-US-V2**  
S/N:  
**XXXXXXXXXXXX**

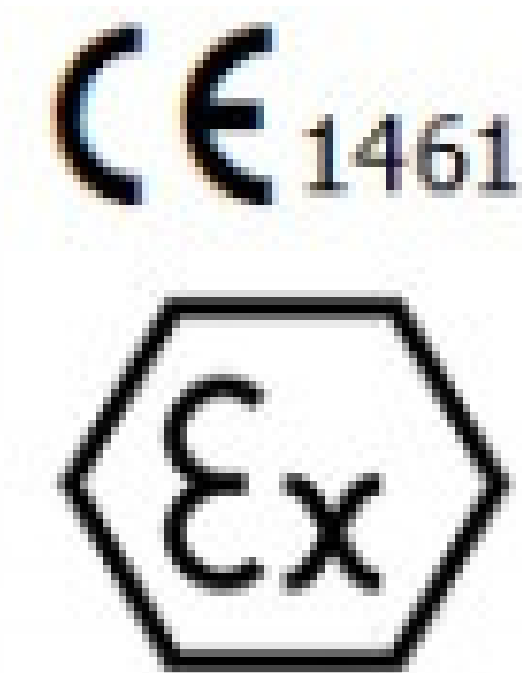

Contains FCC ID:QI00XS8 Groups C&D, Class 1 Div.1,  
Ex ia IIB T4 Ga -40°C ≤ Ta ≤ +68°C IP 68

**Ui** (12VDC Connector P4) = 12.0Vdc maximum

**Ii** (12VDC Connector P4) = 1.65A to 2.2A

**Qi** (Sense Inputs@ Connectors P1, P2, P3) = 200uF

**Li** (Sense Inputs@ Connectors P1, P2, P3) = 2.5mH

**Vo** (12V Supply Pins@ Connectors P1, P2) = 12VDC

**Io** (12V Supply Pins@ Connectors P1, P2) = 350mA

**Co** (Comm' Pins RS232, RS485, SDI Connectors P1) = negligible

**Lo** (Comm' Pins RS232, RS485, SDI Connectors P1) = negligible

**Lo, Co** (External Antenna Connector) = negligible

**Warning: Explosion Hazard.** Do not open or service the unit or disconnect/reconnect the connectors in the presence of hazardous atmosphere. **Avertissement: Risque d'explosion.** Ne pas ouvrir ou entretenir l'unité ni déconnecter/reconnecter les connecteurs en présence d'une atmosphère dangereuse.

**Warning:** Carefully follow the user and Installation manual instructions to maintain safety in Hazardous area locations. As an "X" marked product, installation instructions in the manual require special procedures and precautions to ensure the safety of the personnel performing the operations and to comply with Ex restrictions.

**Avertissement:** Suivez attentivement les instructions du manuel d'installation et de l'utilisateur pour maintenir la sécurité dans les zones dangereuses/ En tant que produit marqué "X", les instructions d'installation du manuel requièrent des procédures et des précautions spéciales pour assurer la sécurité du personnel effectuant les opérations et pour se conformer aux restrictions Ex.

# IMPORTANT



Contact the Ayyeka Support Team for technical assistance:

support@ayyeka.com

+1 (310) 876-8040 (US)

+972-2-624-3732 (IL)

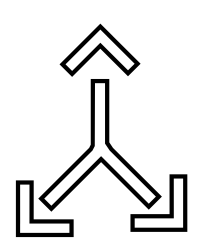

Always coordinate the installation with the local authority before starting installation. Installation should be completed by trained and authorized personnel. If assistance from Ayyeka Support is needed, schedule a request in advance, and make **sure that you get confirmation before the installation.**

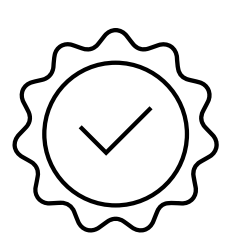

The Ayyeka Limited Warranty covers only Ayyeka-supplied hardware and software for the duration of the warranty period as per the warranty terms and conditions.

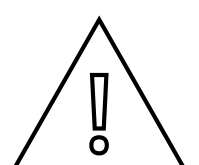

Ayyeka is not liable for damage or injury as a result of handling, installation, or maintenance of its supplied systems.

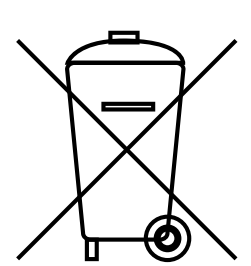

Do not throw away the device because it contains a lithium battery. Dispose of the battery properly according to local laws and regulations.



4G (LTE)/3G/2G cellular network signal is required for proper communication.

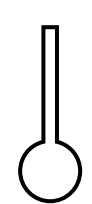

Operating temperature range: -40°C to +68°C (-40°F to +154°F)

# SAFETY MESSAGE

This manual applies Hazard Severity Levels to the safety alerts. These three levels are described in the sample alerts below.

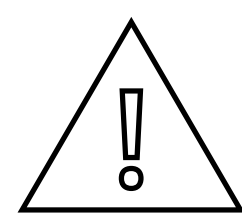

## CAUTION

Cautions identify a potential hazard, which if not avoided, may result in minor or moderate injury. This category can also warn you of unsafe practices, or conditions that may cause equipment or property damage.



## WARNING

Warnings identify a potentially hazardous condition, which if not avoided, could result in death or serious injury.

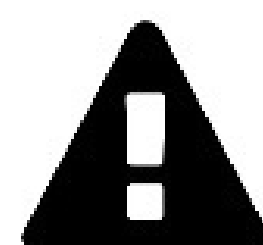

## DANGER

Warnings identify a potentially hazardous condition, which if not avoided, could result in death or serious injury

# SAFETY MESSAGE

Procedures and instructions in this manual may require special precautions to ensure the safety of the personnel performing the operations. Refer to the safety messages listed at the beginning of each section before performing an operation preceded by this symbol.

Failure to follow installation guidelines could result in serious injury or death. Make sure only qualified personnel perform this installation.

Use the equipment only as specified in this manual. Failure to do so may impair the protection provided by the equipment.

Before installing, operating, or maintaining this equipment, it is imperative that all hazards and preventive measures are fully understood. While specific hazards may vary according to location and application, take heed in the following general warnings.



## **WARNING**

Do not open unit or service the unit in the presence of a hazardous atmosphere.



## **WARNING**

Do not disconnect/reconnect the unit after installation while power is on internally and/or externally.



## **WARNING**

Read and follow all instructions for operation and installation to maintain safety in hazardous area locations. As an "X" marked product, special attention is needed to written manufacturer procedures for specific installation instructions to comply with Ex restrictions.

## SPECIAL CONDITIONS OF USE

Marked "X" - Conditions to be explained in instructions and in the Certificate "Special Conditions of Use":

The Ex Wavelet works with an internal battery. There is an optional connection for an external power supply.

An external power supply connection requires that you use a special safety barrier. The external power supply cannot be connected directly to the device.

For operating the device on an external power supply, please consult with an Ex technical expert.

It must be of a suitably certified LPS and SELV Type and output over-voltage and short circuit protected according to the latest edition of Electrical Safety Standard(s) EN/UL/IEC 62368-1 or EN/UL/IEC 60950-1 or the equivalent Standard.

The external supply source must be of output ratings at 12VDC maximum and between 1.65-2.2.

The configured external connection assemblies (combination of connectors and cables) must be pre-assembled in an ordinary, non-classified area - not in the presence of an Explosive Atmosphere. Installation instructions include information on the selection of specific sealed connectors and cables to be used in these assemblies.

The last remaining step in the installation is to be done within the Explosive Atmosphere, but it must be done with the power supply disconnected from the equipment (external source and internal battery supply - via reed switch). Only after all assembly connections are complete may the external power supply be powered on.

Additionally, the equipment connections must not be disassembled for service with the power supply energized. Refer to Manufacturer installation procedures, requirements, and description of components used in constructing the harnesses, and to the User Manual and Installation Guide for Explosive Zone, Ayyeka Ref. 0100592 for external connection assemblies.

A polarized "Protector" guard, which is part of the Explosive Environment requirement, is installed over the unit's external connectors to disable disconnection after the equipment is installed in the Explosive Environment.

The following WARNING is to be marked on the equipment in a visible area, and the Instruction Manual must include explanations of these instructions:



**WARNING**

Explosion Hazard. Do not open or service the unit or disconnect/reconnect the connectors in the presence of hazardous atmosphere.



# INTRINSIC SAFETY

Intrinsic Safety (IS) is an approach to the design of electronic equipment going into hazardous areas that ensures there are no conditions under which the equipment can operate that could cause a release of energy sufficient to ignite a hazardous gas vapor or dust mixture. Devices that meet the low power, current-limited design criteria are deemed Intrinsically Safe (IS).

The Wavelet has been certified and tested to worldwide IECEx (International Electrotechnical Commission Explosive) standards. The IECEx scheme allows demonstrated compliance for use in Zone 0 (equivalent to Class 1, Division 1 in North America) areas in the following countries:

United States, India, Slovenia, Denmark, Germany, Russia, Croatia, Netherlands, Poland, Canada, South Korea, Switzerland, Australia, Italy, South Africa, Finland, Hungary, Singapore, Czech Republic, New Zealand, Romania, China, Malaysia, Turkey, Brazil, Japan, Sweden

# CONTROL DRAWING

The control drawing Assembly No. 0100591 depicted below provides the recommended electrical layout for the installation.

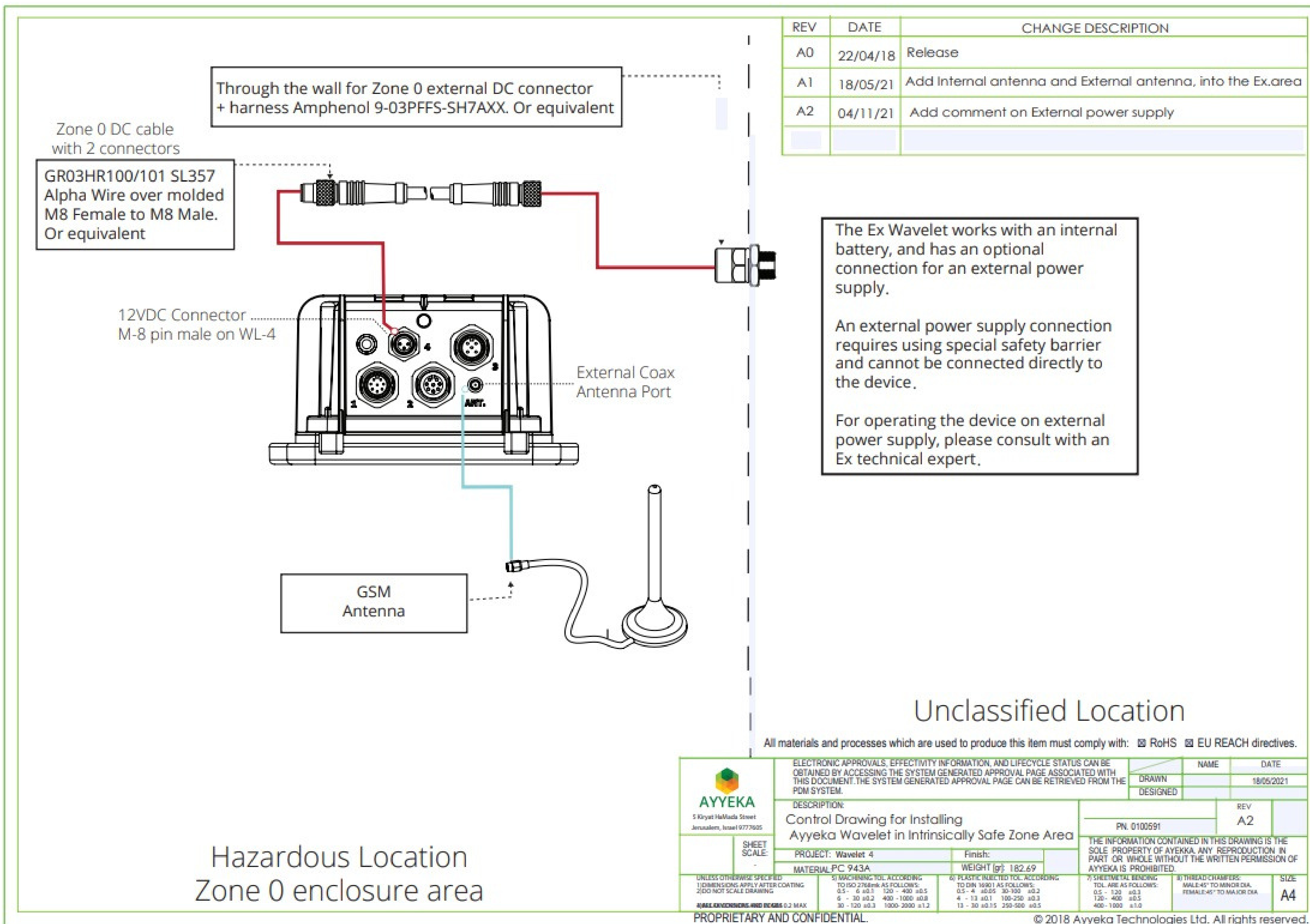

Use the equipment only as specified in this manual and according to the intrinsic safety control drawing. Failure to do so may impair the protection provided by the equipment.

# SCHEMATIC

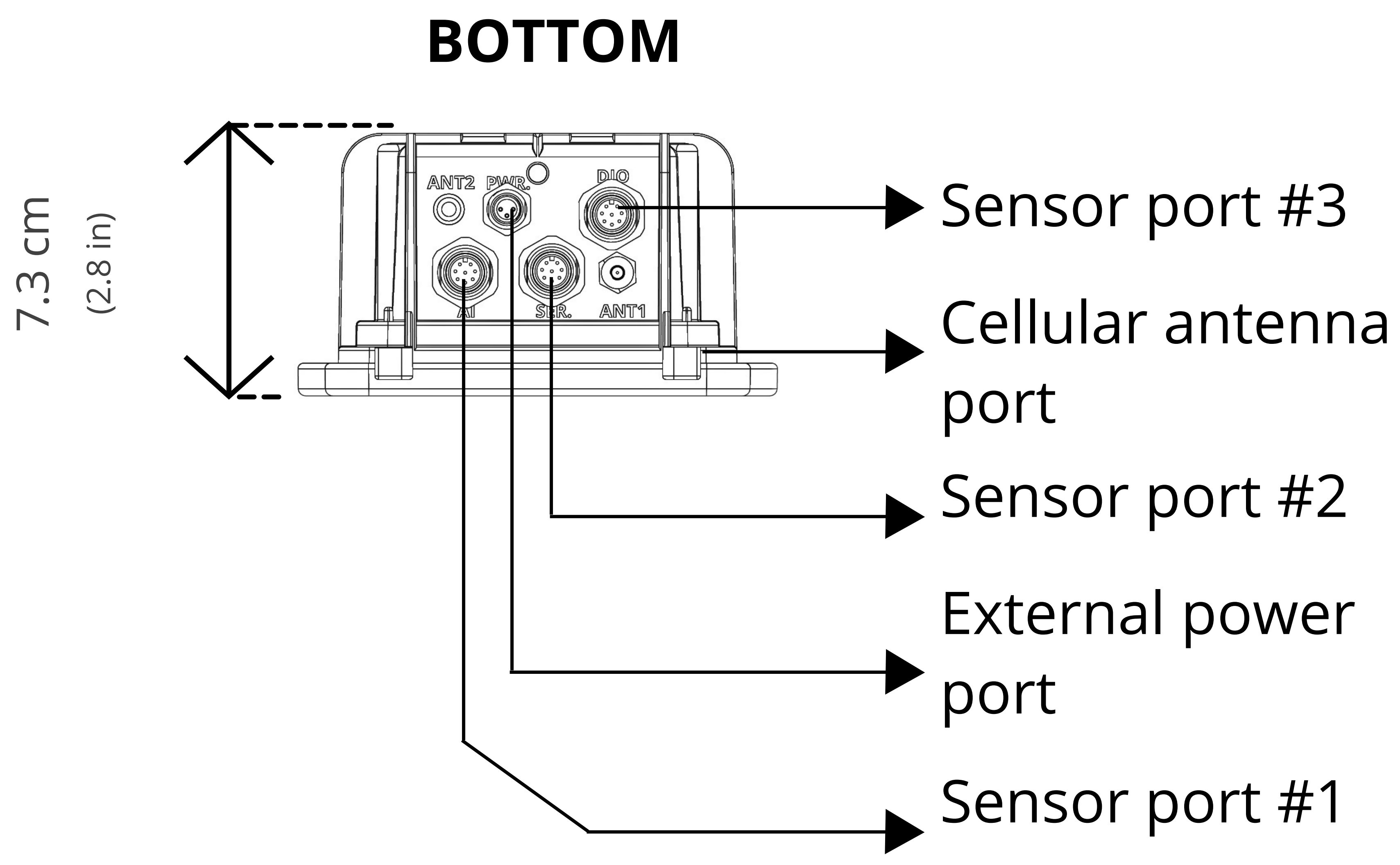
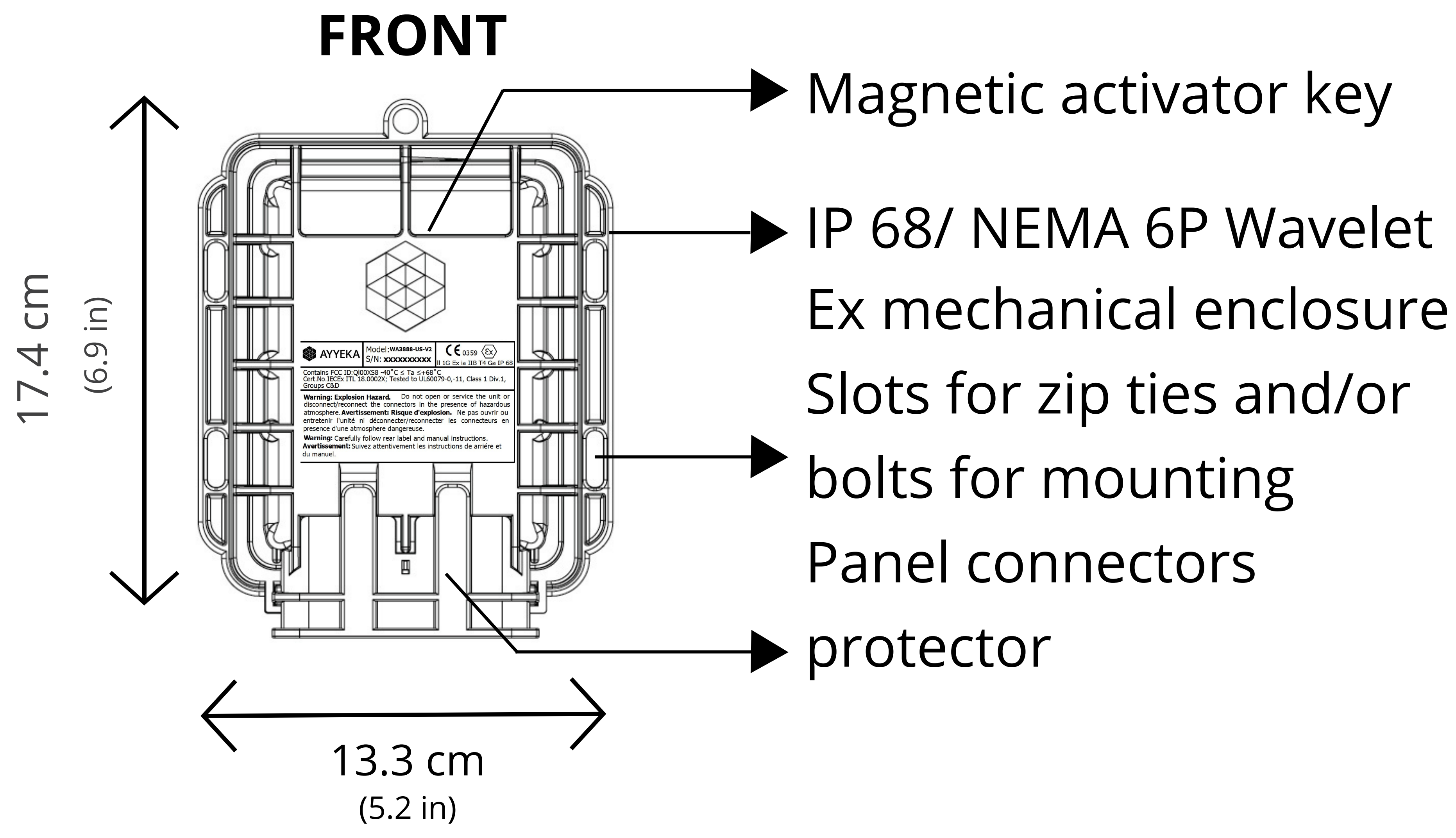

# SCHEMATIC

## INTERNAL UPPER ENCLOSURE

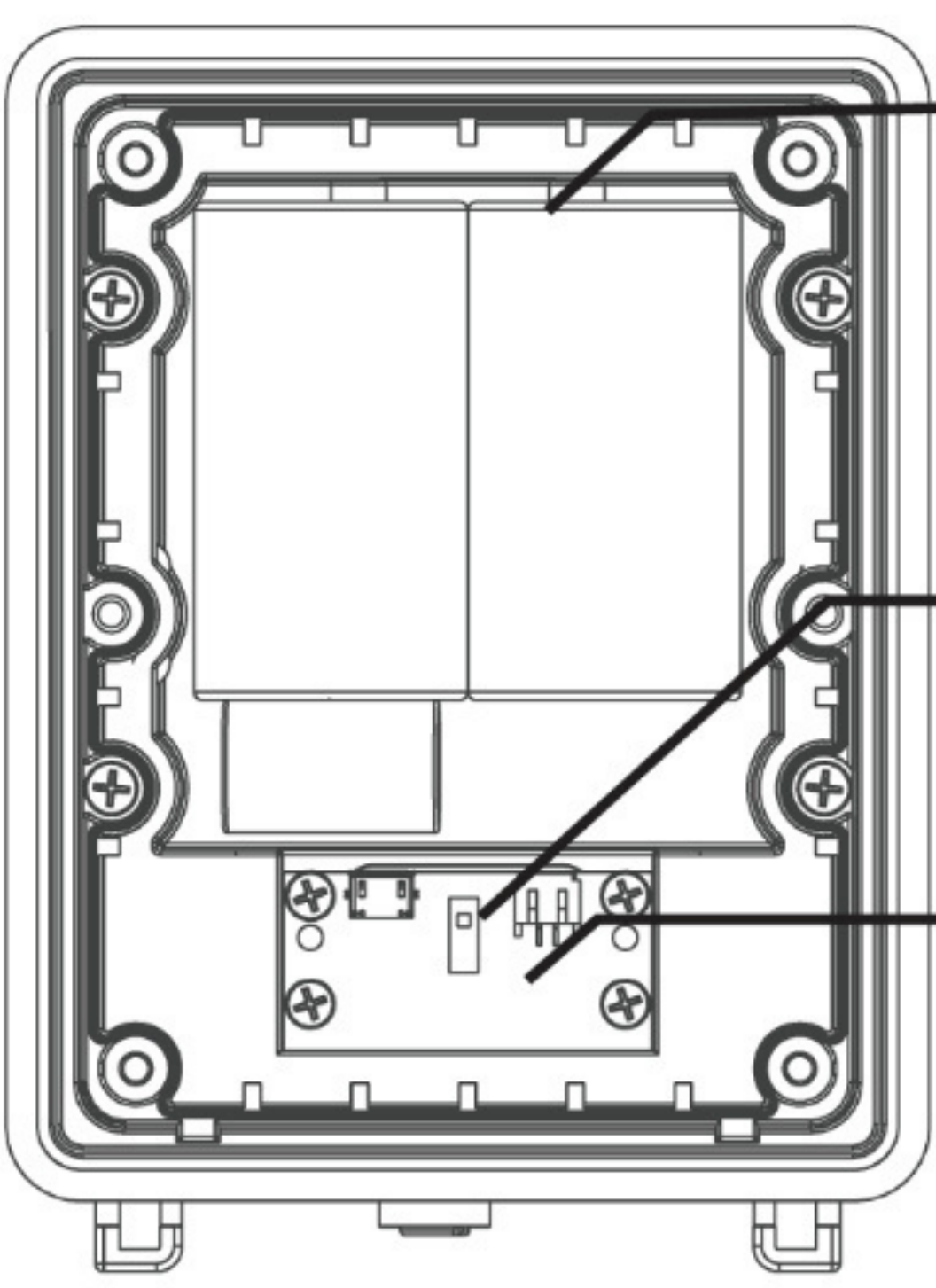

- Military-grade, potted lithium battery pack (field replaceable, non-rechargeable)
- Interface board ON/OFF switch
- Indicator LEDs

## INTERNAL LOWER ENCLOSURE

**NOTE: Potted**

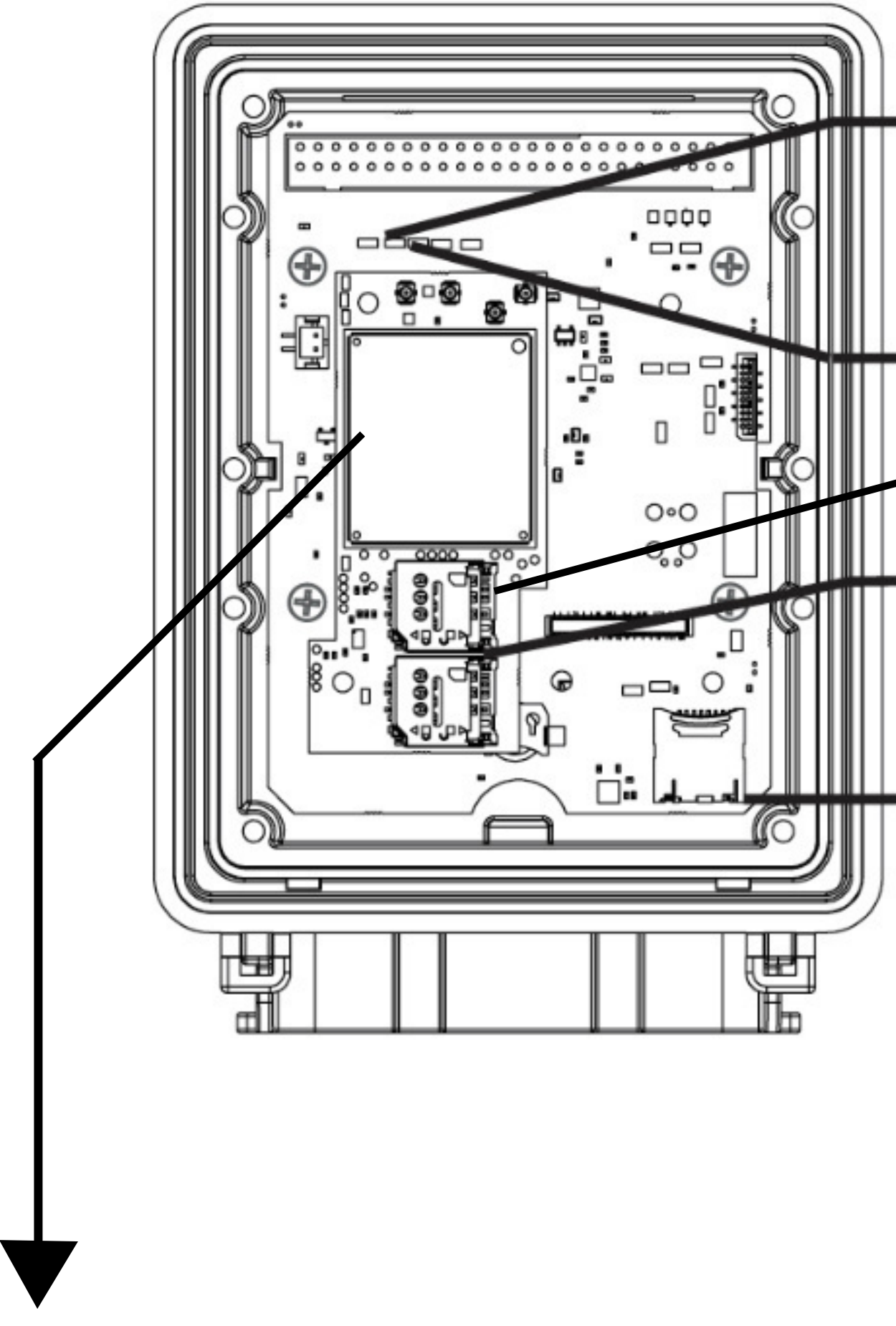

- GSM antenna
- GPS antenna
- SIM card slot #1
- SIM card slot #2
- Memory card

Cellular modem

# COMPONENTS

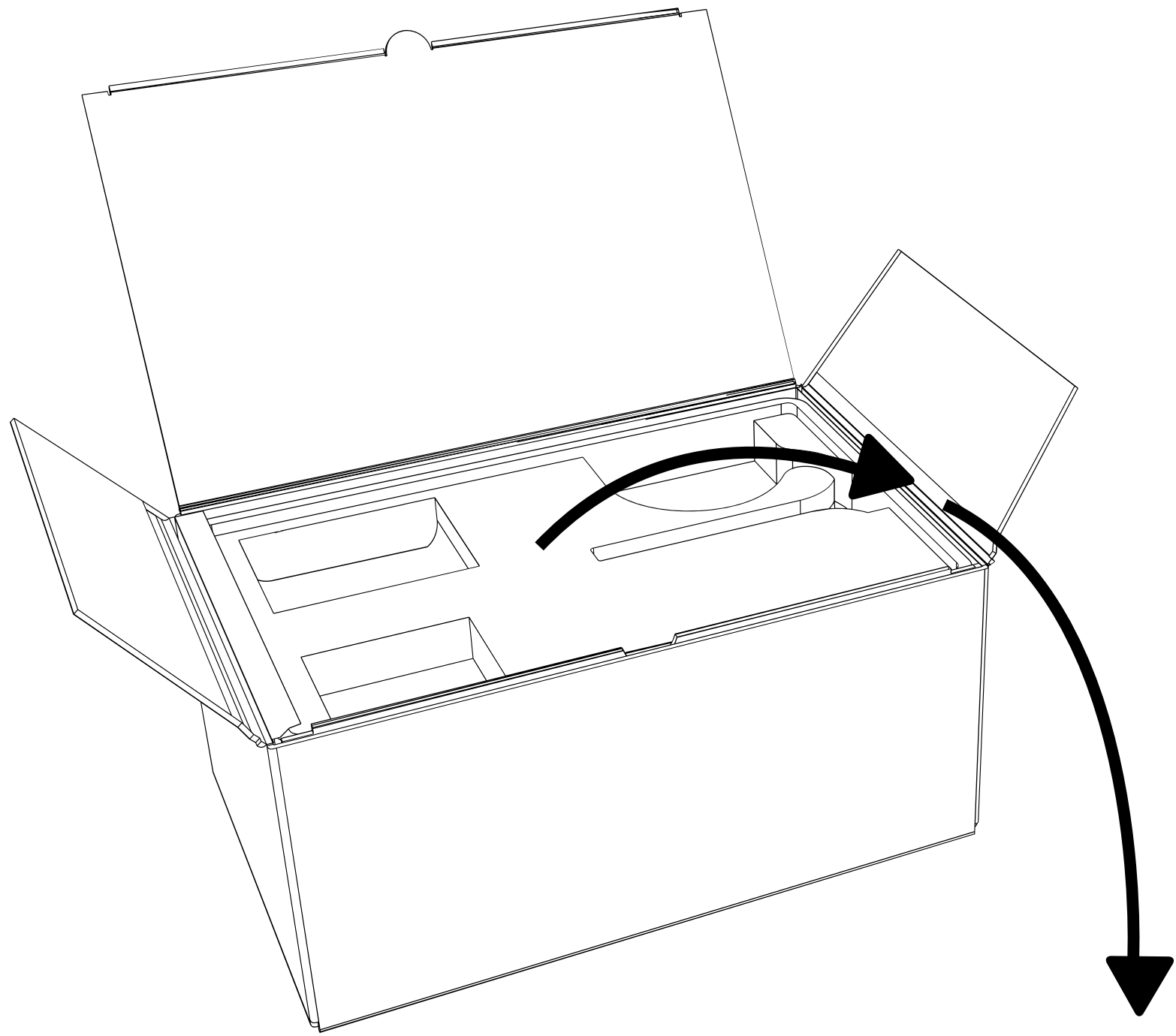

**Wavelet Ex Device**

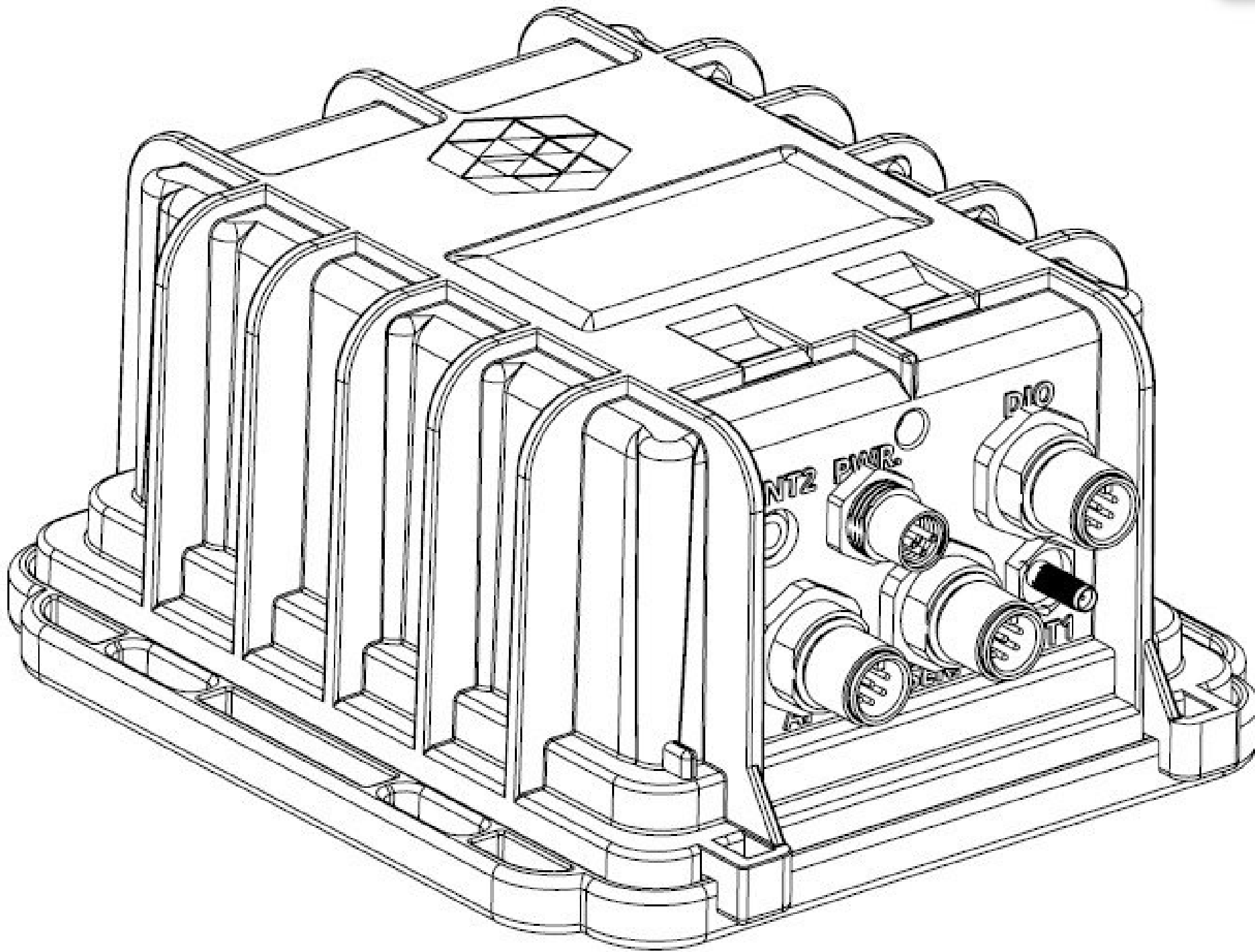

**M12 8-pin female field attachable sensor connectors**  
(Optional; ordered separately)

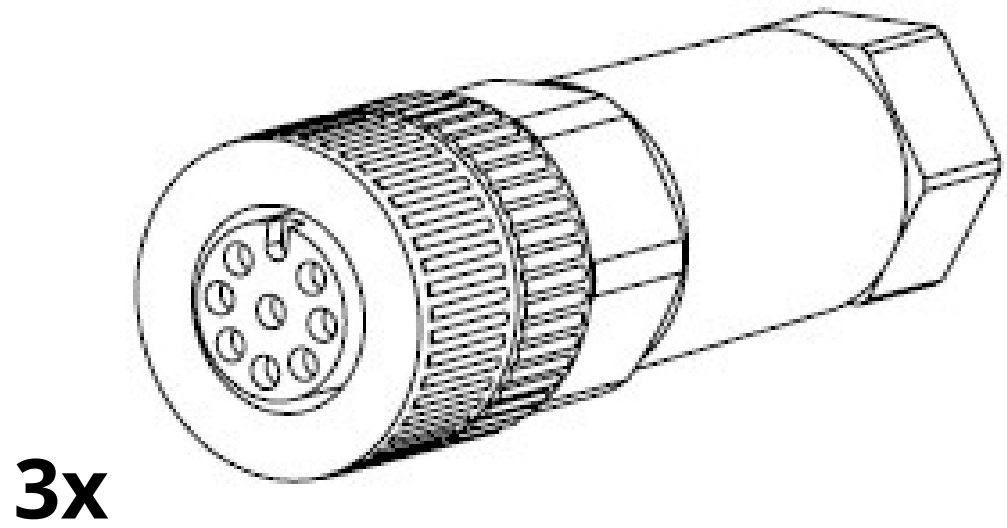

3x

**Magnet Activator Key**

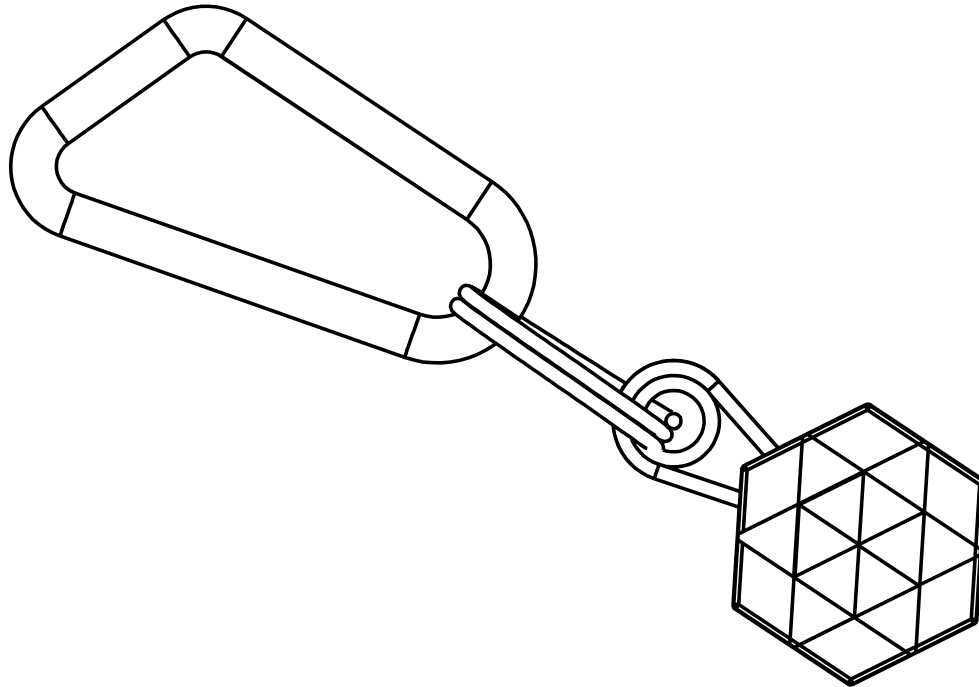

**Panel connectors protector and security screw**

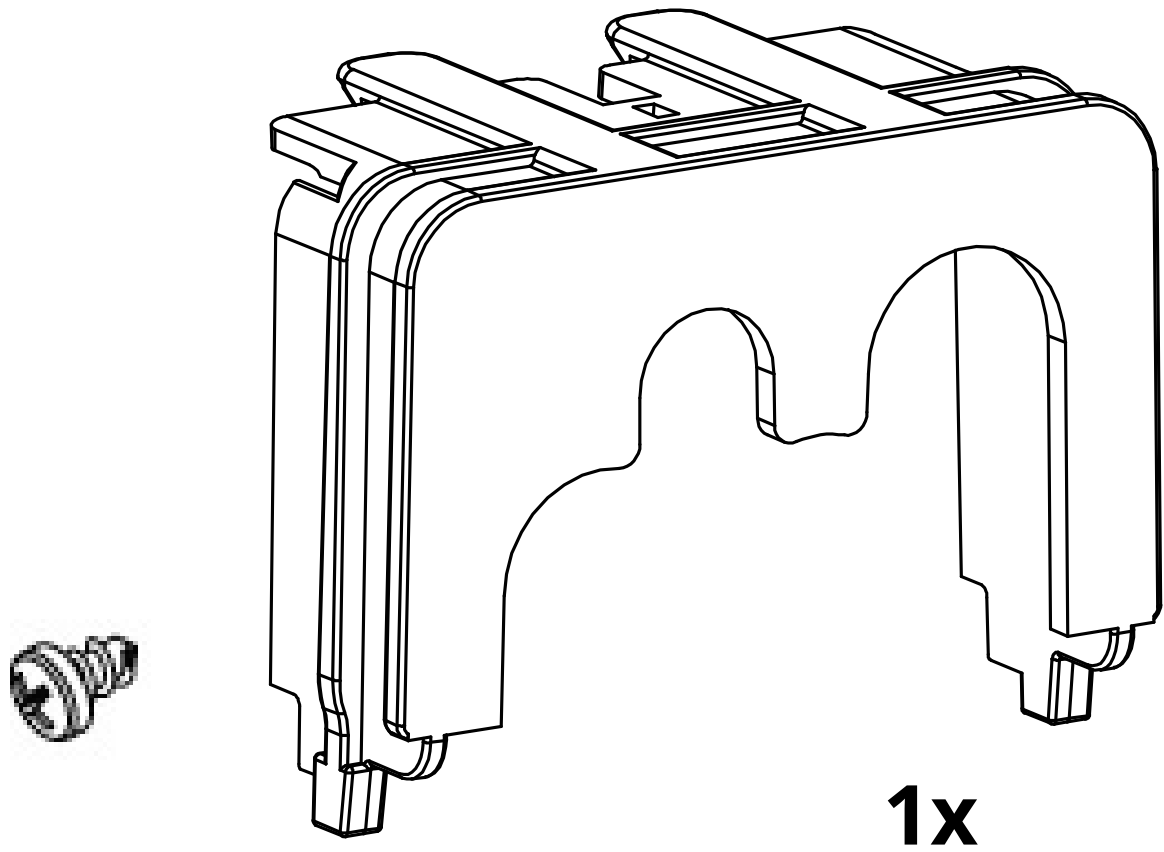

1x

**M8 female field attachable power connector**  
(Optional; ordered separately)

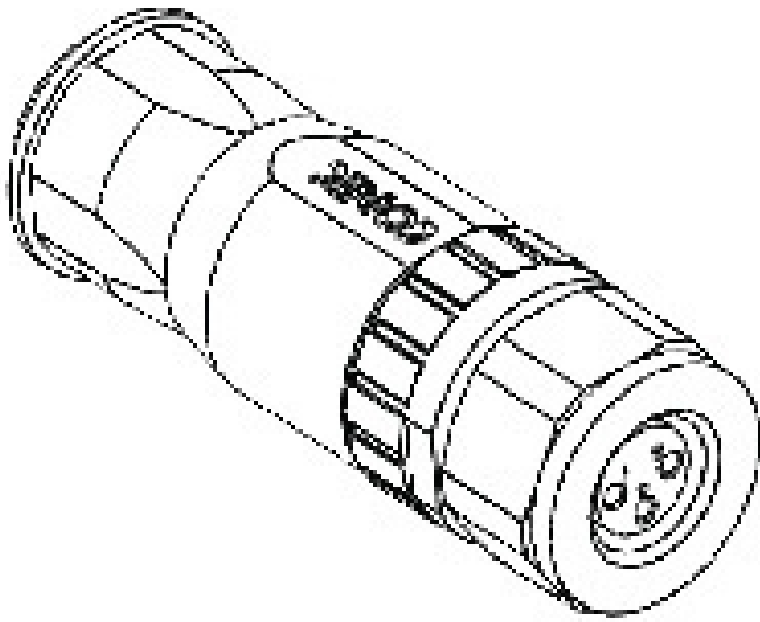

1x

# COMPONENTS

## Cellular antenna and mounting bracket

(REQUIRED and sold separately)

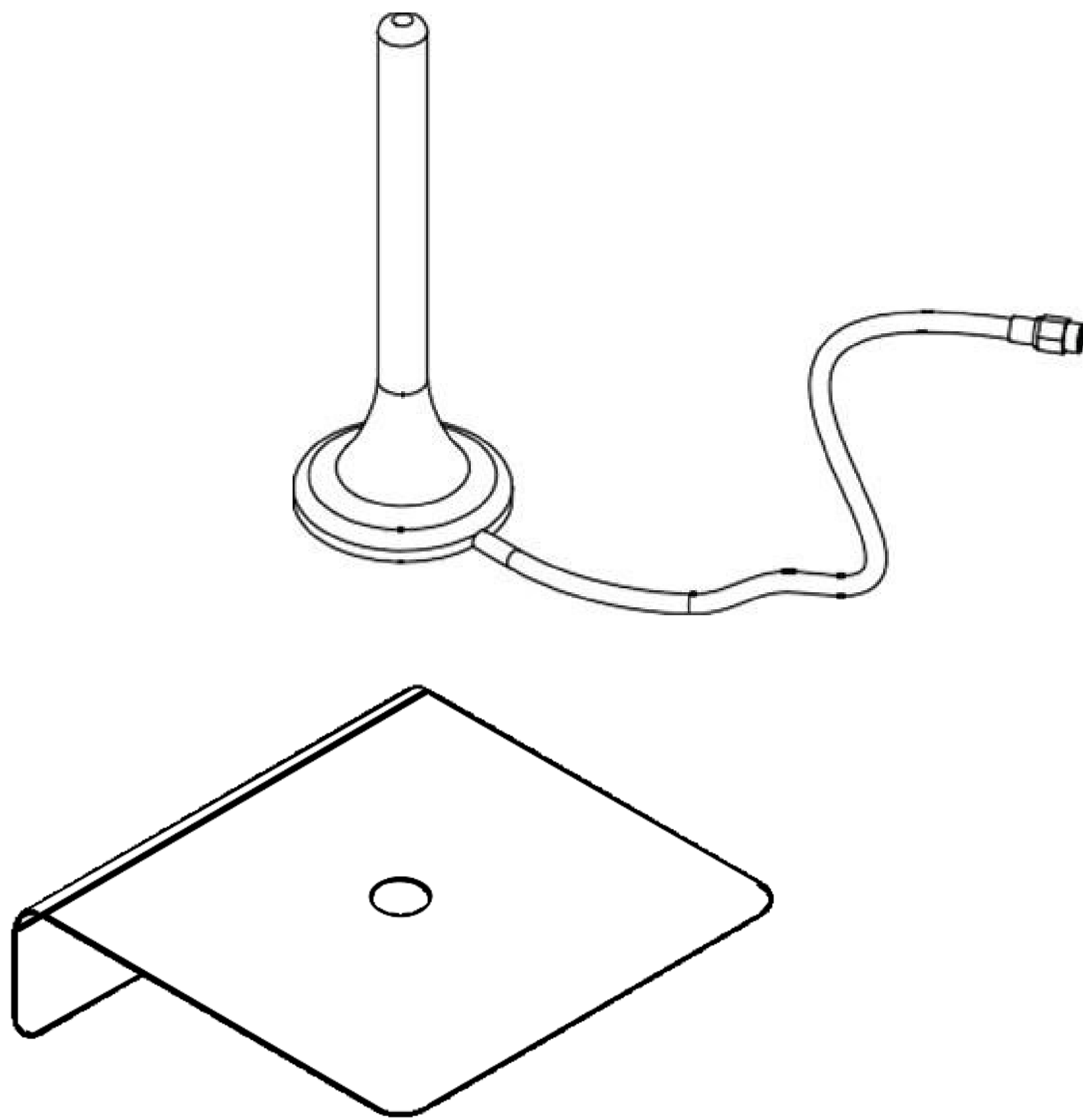

## Zip ties, screws, and anchors

(Optional; sold separately)

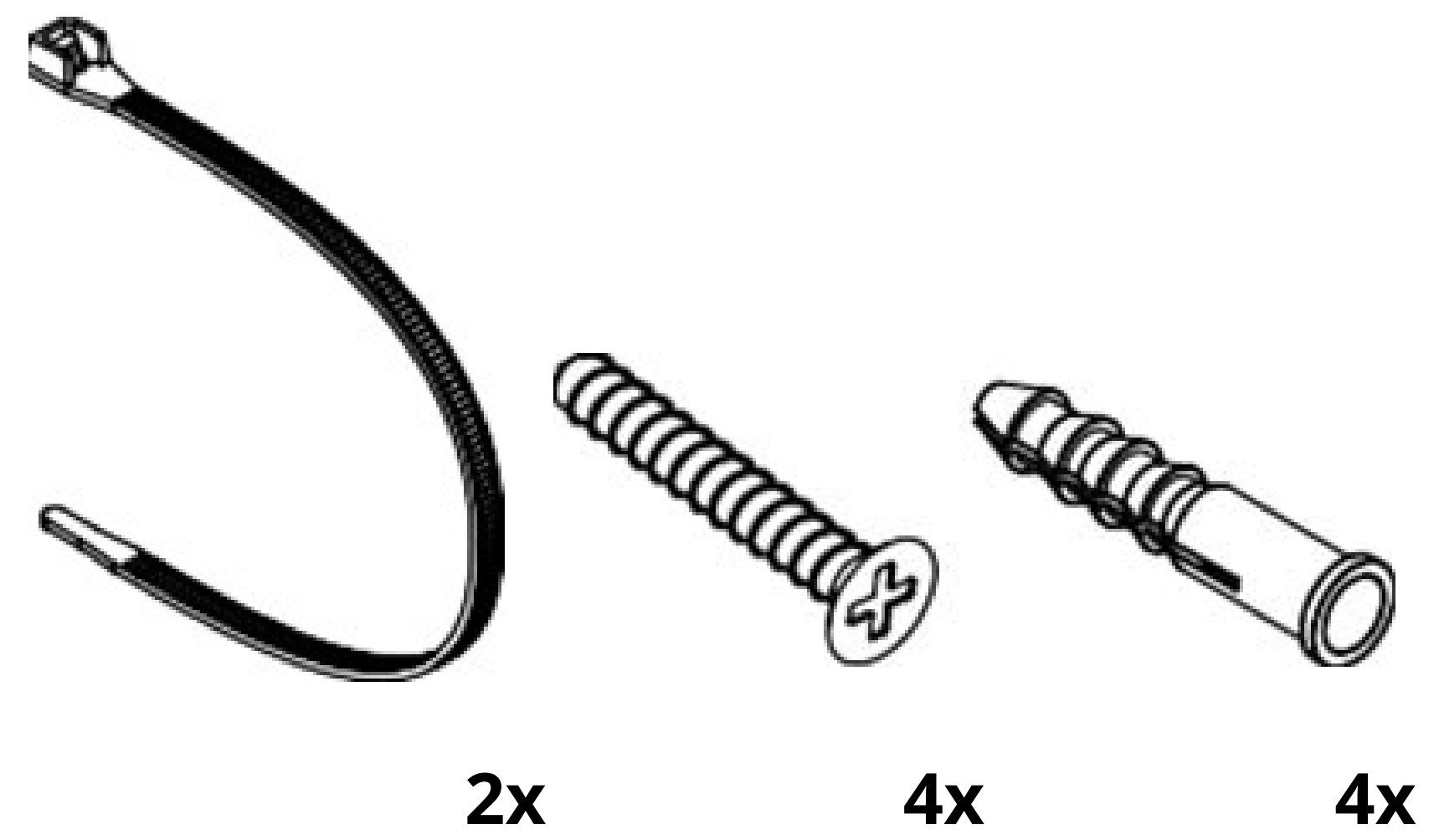

# SENSOR CONNECTION



## WARNING

Connection of sensor(s) to the device must be done in an unclassified zone. Failure to perform this action in an unclassified zone may cause dangerous conditions.

1

Connect the sensor cable(s) assembly with the field attachable connector to the mating panel connector on the device. Turn the adjustable stainless-steel end piece to secure the field attachable connector to the device.

**IMPORTANT:** Use the DEVICE PINOUT sheet at the end of this Guide to know which device port to plug the sensor into. All device ports look identical, but their internal wiring is different. Consequently, the sensor will not work if it is plugged into the wrong port.

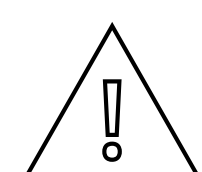
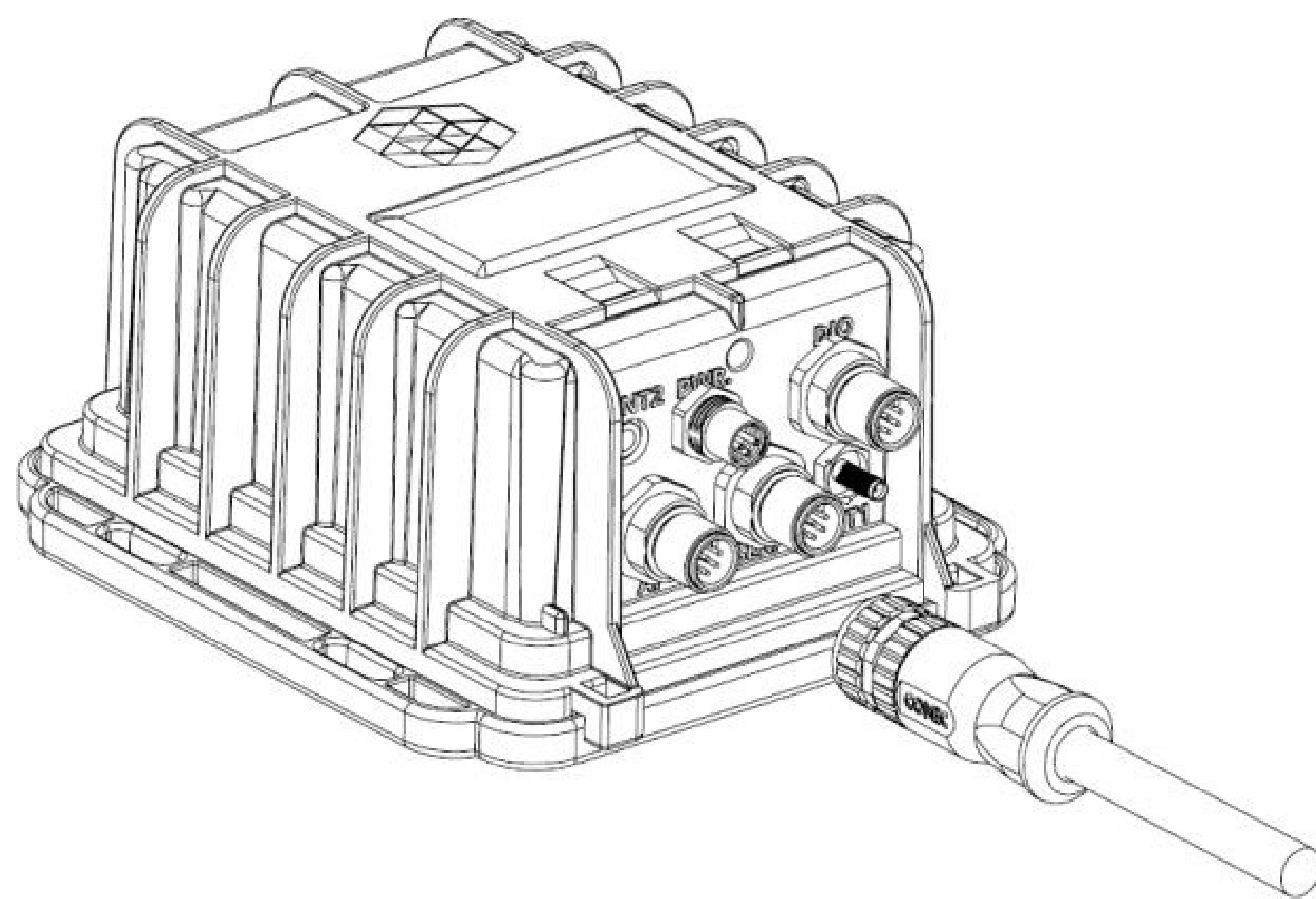

**CAUTION:** Do not turn the black plastic hood of the connector. Turning the black hood may cause the wires to disconnect, break, and/or damage the connector pins.

TURN HERE

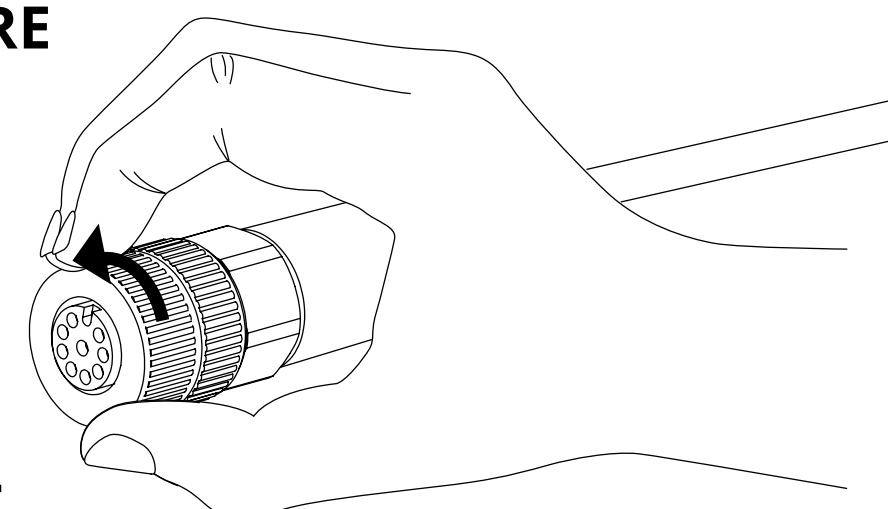

DO NOT  
TURN HERE

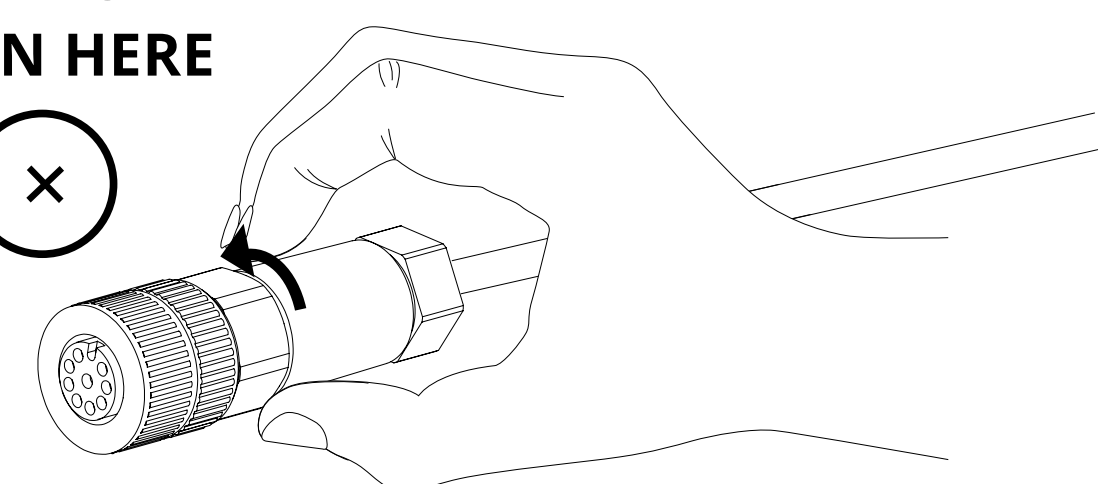
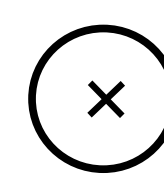

# EXTERNAL ANTENNA CONNECTION

- 2 Connect the Cellular antenna to the antenna port (ANT1).

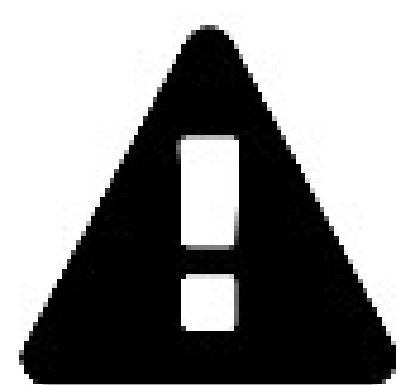
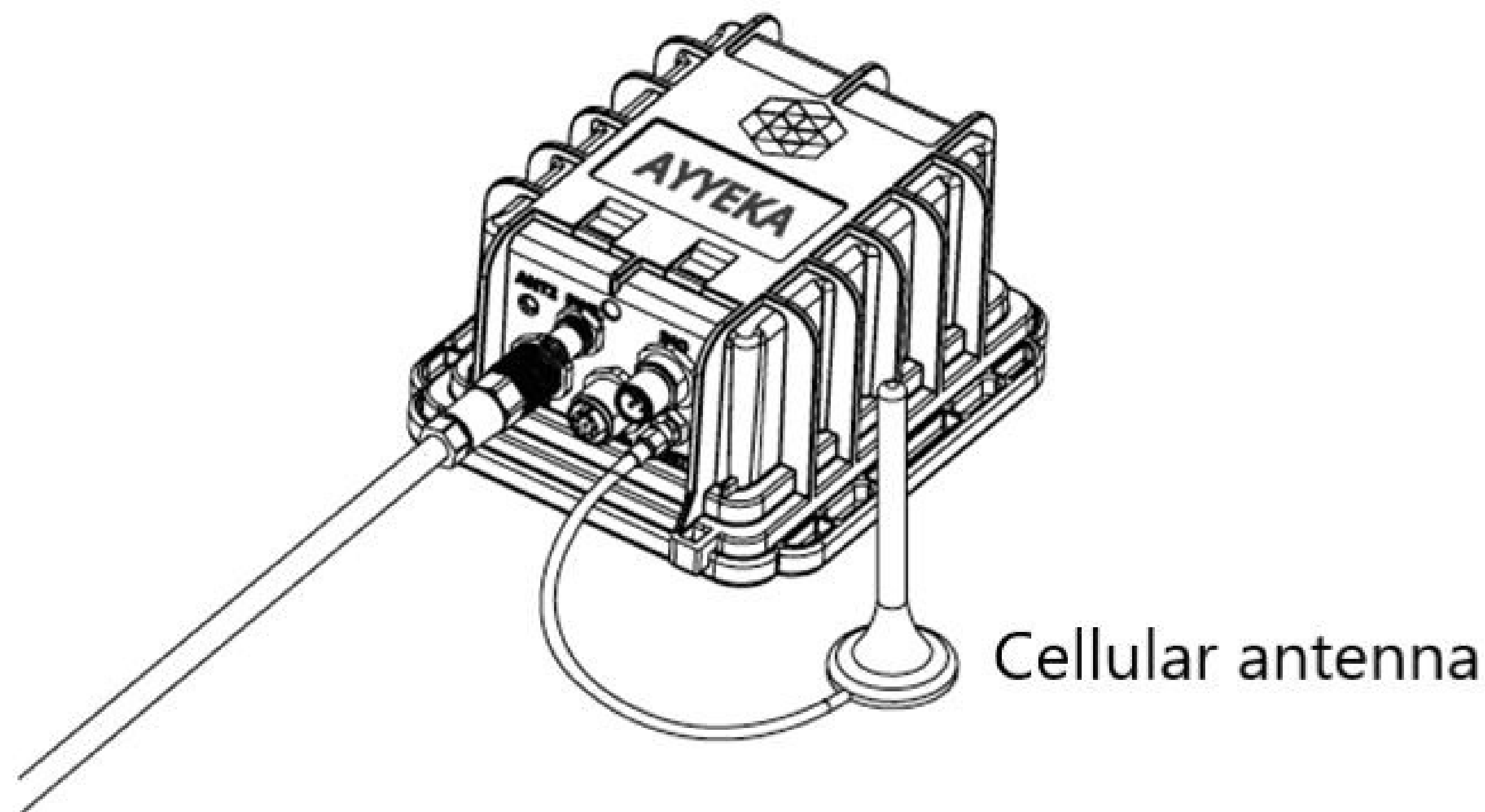

The antenna does not appear in the remaining depictions in this guide, but it must remain connected after it is properly secured to the appropriate panel connectors.



# DEVICE ACTIVATION



## WARNING

The device should first be tested in an unclassified zone. Failure to perform this initial testing action in an unclassified zone may cause dangerous conditions.

3

Place the magnetic device activator key on the embossed logo on the front of the device enclosure and hold for 3 seconds. Device will initiate a 15-minute test mode of high frequency sampling and transmission. The device will then return to its default configuration. You can verify the Wavelet has been activated using the LED on the back panel (see page 18).

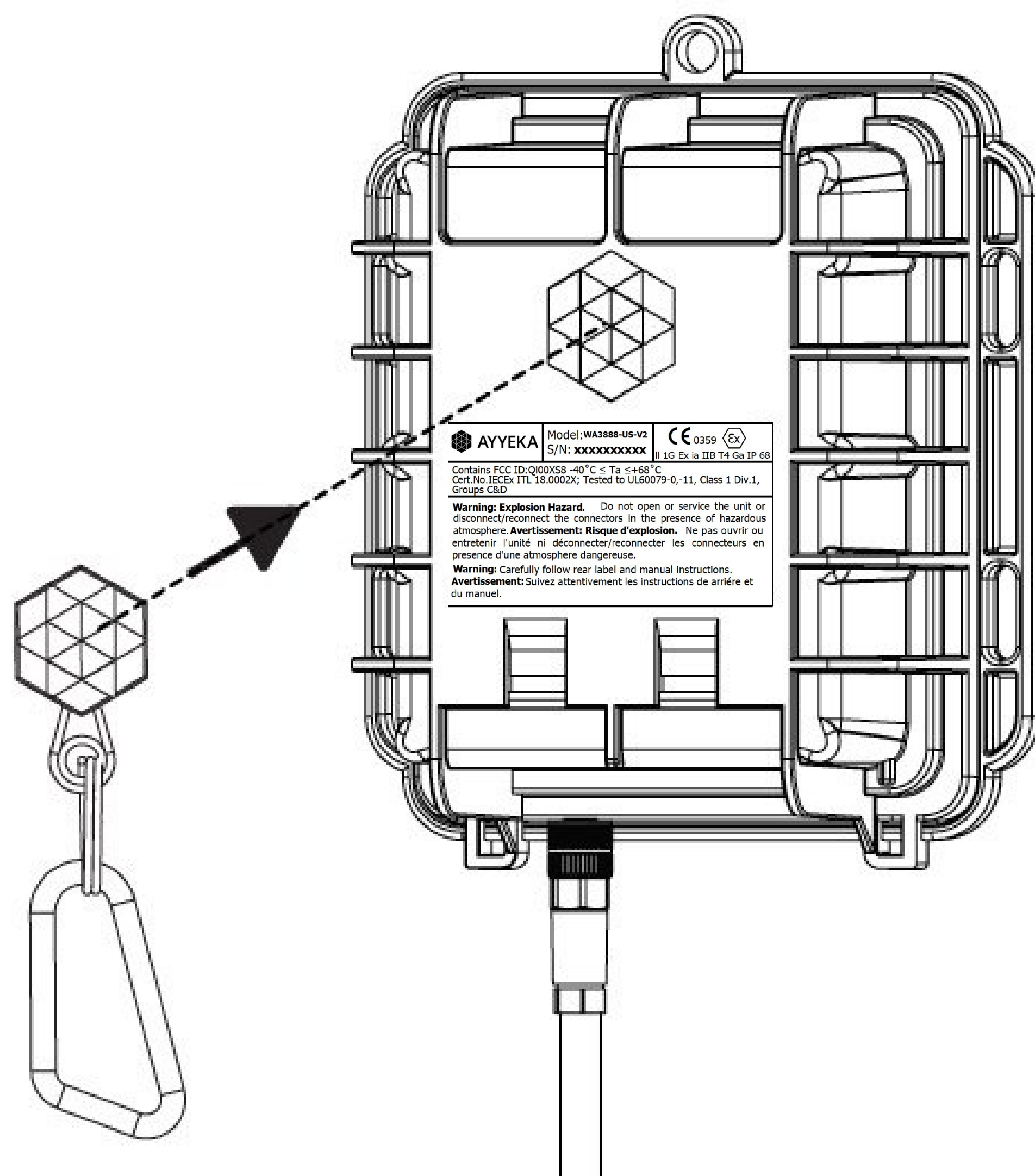

# DEVICE ACTIVATION

The LED light on the back cover of the device indicates the device status.

Function	Description
All LEDs are off	Not connected to network. The LED lights do not blink when the device is sampling.  Note: Device may be powered down (power switch is in the OFF position), in Hibernate mode, or have insufficient battery strength.
Green-Red-Blue-Red-Green LEDs blink sequentially 5x	Device is activated using the magnetic activator key.
Green LED is blinking	Attempting to connect to GSM network.
Green LED remains on	Transmission of data is in progress via GSM. The LED will turn off when the transmission is complete.
Green-Red LEDs blink 5x	GSM communication error. The device failed to transmit.

- 4 Access the user interface at <https://home.ayyeka.com> using your credentials. Expect data to appear within 15 minutes after the test mode is initiated.

# DEVICE ACTIVATION

The screen display should resemble the following:

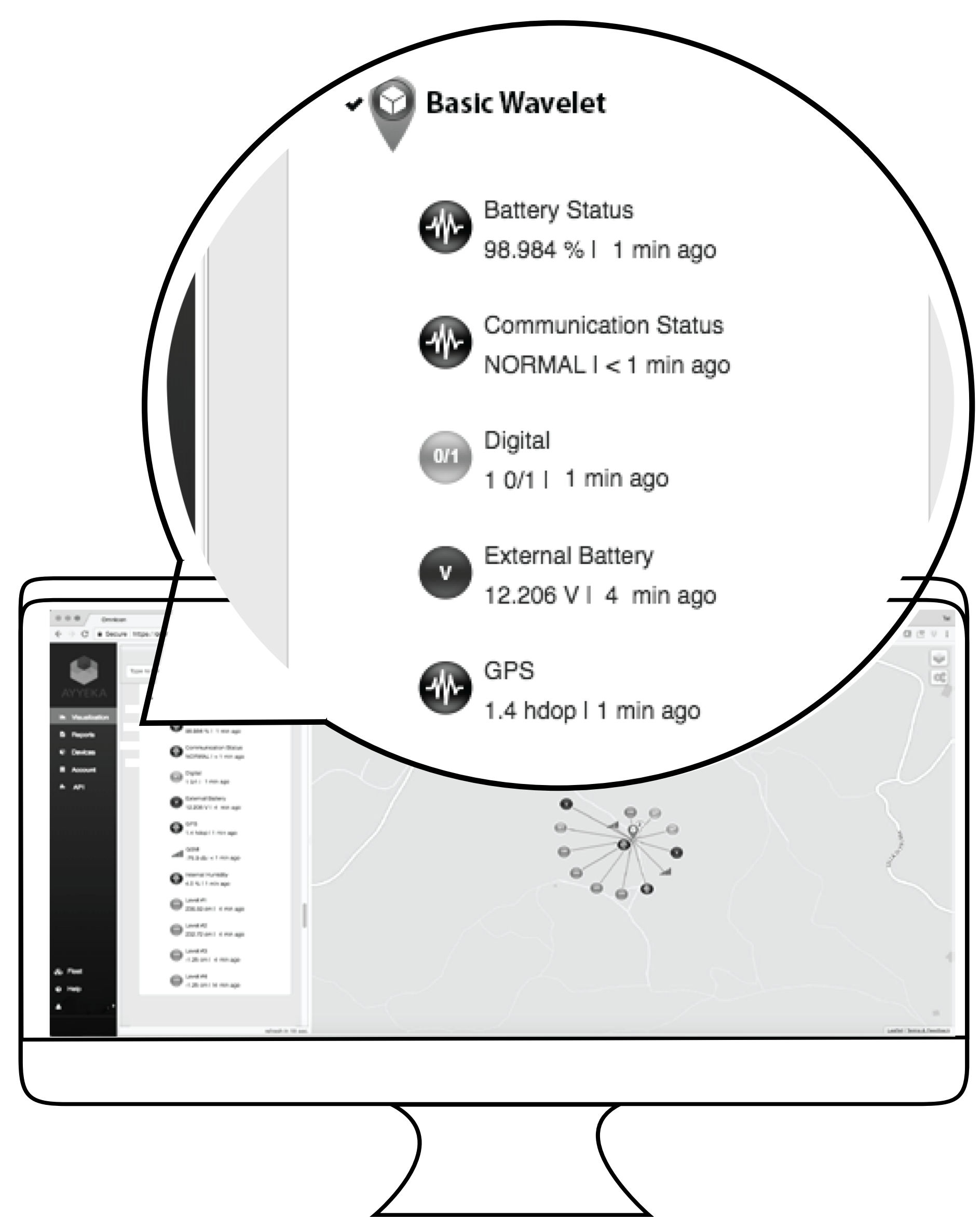
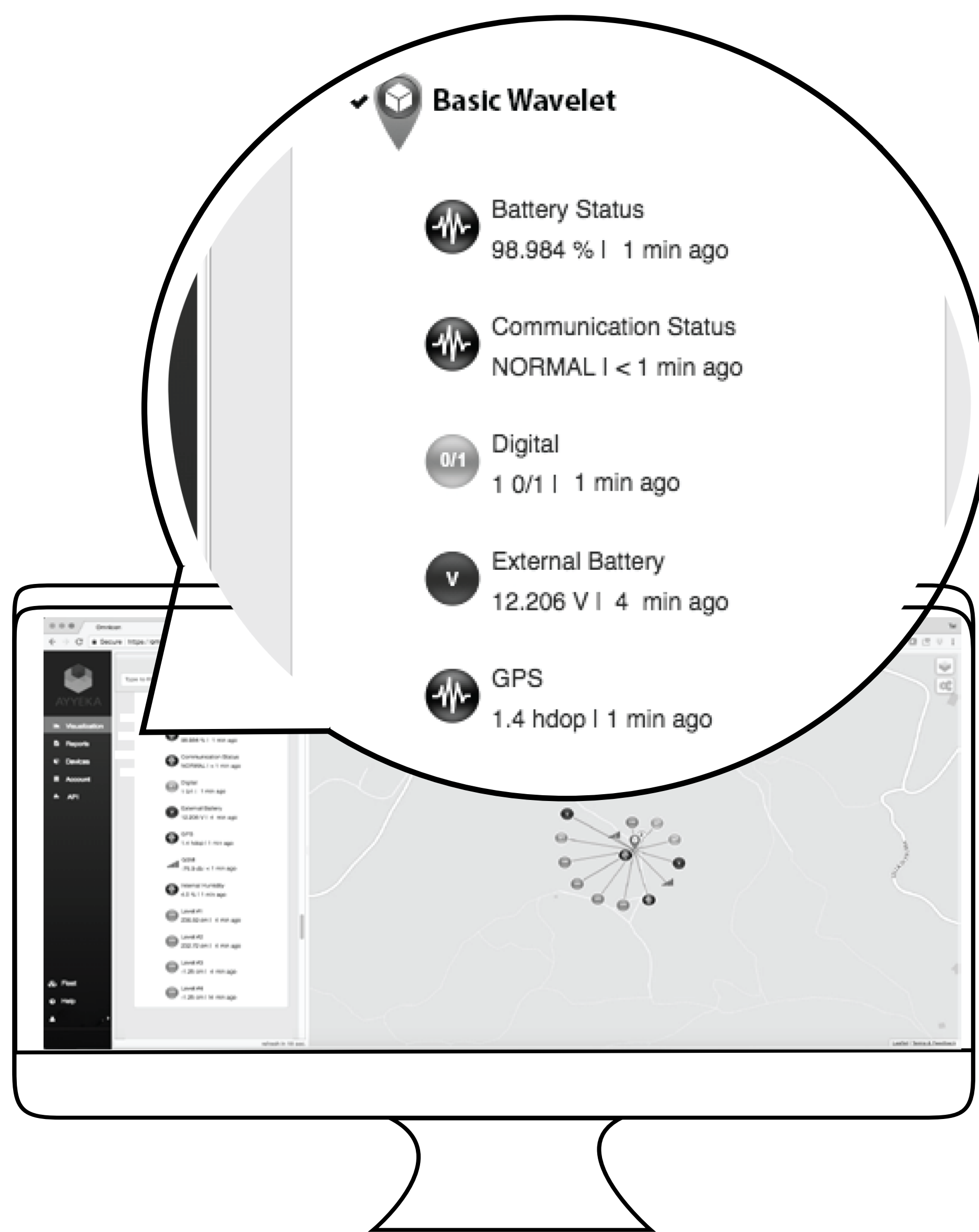

If the device transmits properly, you have completed the installation successfully and can begin collecting and viewing your data!

If data does not transmit properly, change the device installation location and activate again.

If the problem persists, contact the Ayyeka Support Team for help:

[support@ayyeka.com](mailto:support@ayyeka.com)

+1 (310) 876-8040 (US)

+31-40-209-1001 (EMEA)

+972-2-624-3732 (IL)

# AyyekaGo MOBILE APP

5

If you haven't already done so, download the AyyekaGo mobile app for iOS or for Android. Search the App Store or Google Play for "AyyekaGo" or use the QR codes below.

There are two ways to pair your phone with your Wavelet:

1. Select "Get Key Via Web". This will direct you to enter your login credentials for the StreamView user interface.
2. Select "Enter Key Manually". The Mobile Pair Key is found in the StreamView user interface in the Devices tab.

Once connected to your Wavelet device, there are multiple displays screens for different functionality.

The first screen provides essential information, including but not limited to:

- Signal strength
- Cellular carrier
- Confirmation of successful transmission and connection to the server

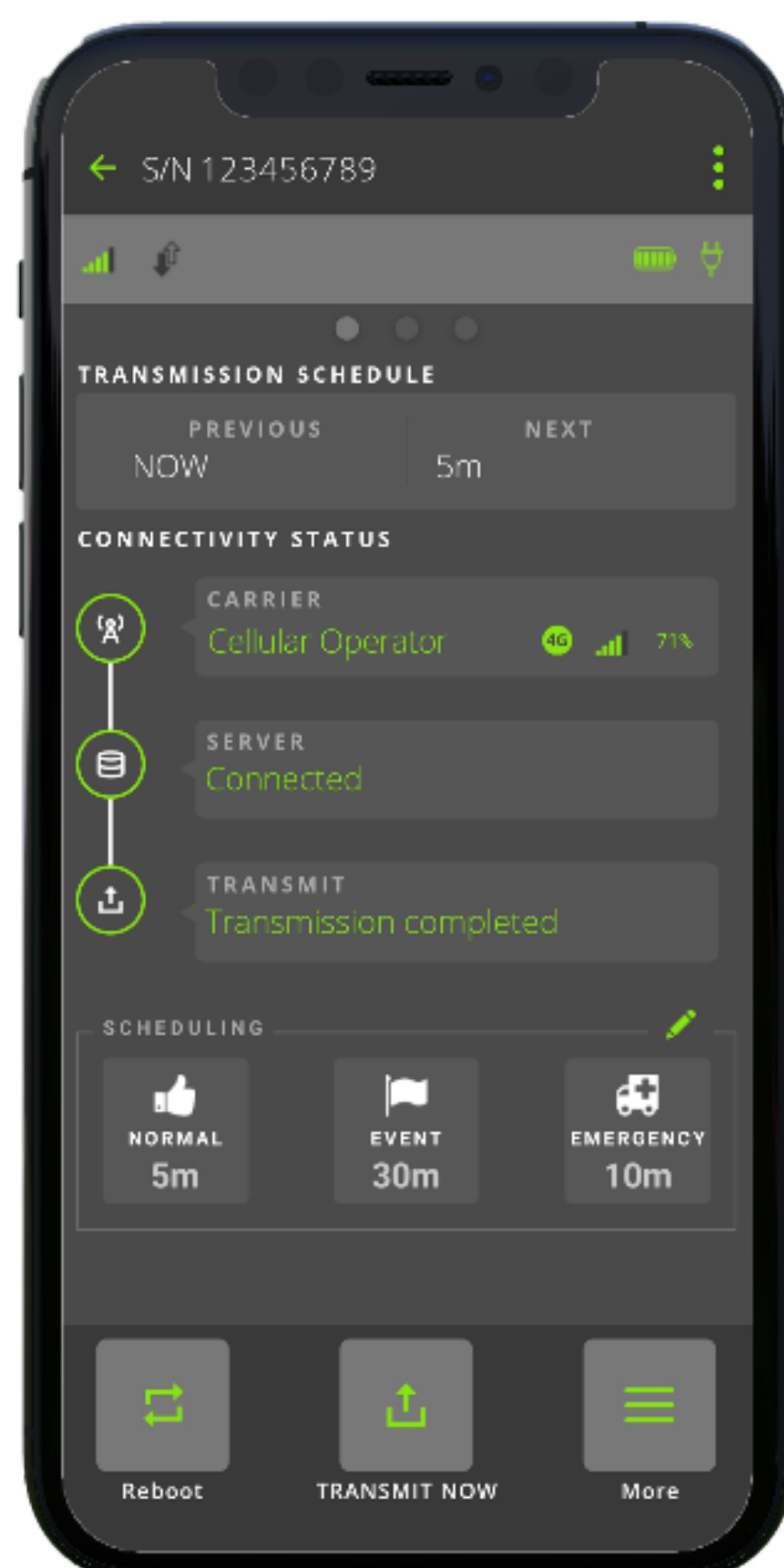

# SPECIAL INSTALLATION LOCATIONS

## WEAK SIGNAL LOCATIONS INDOOR/UNDERGROUND

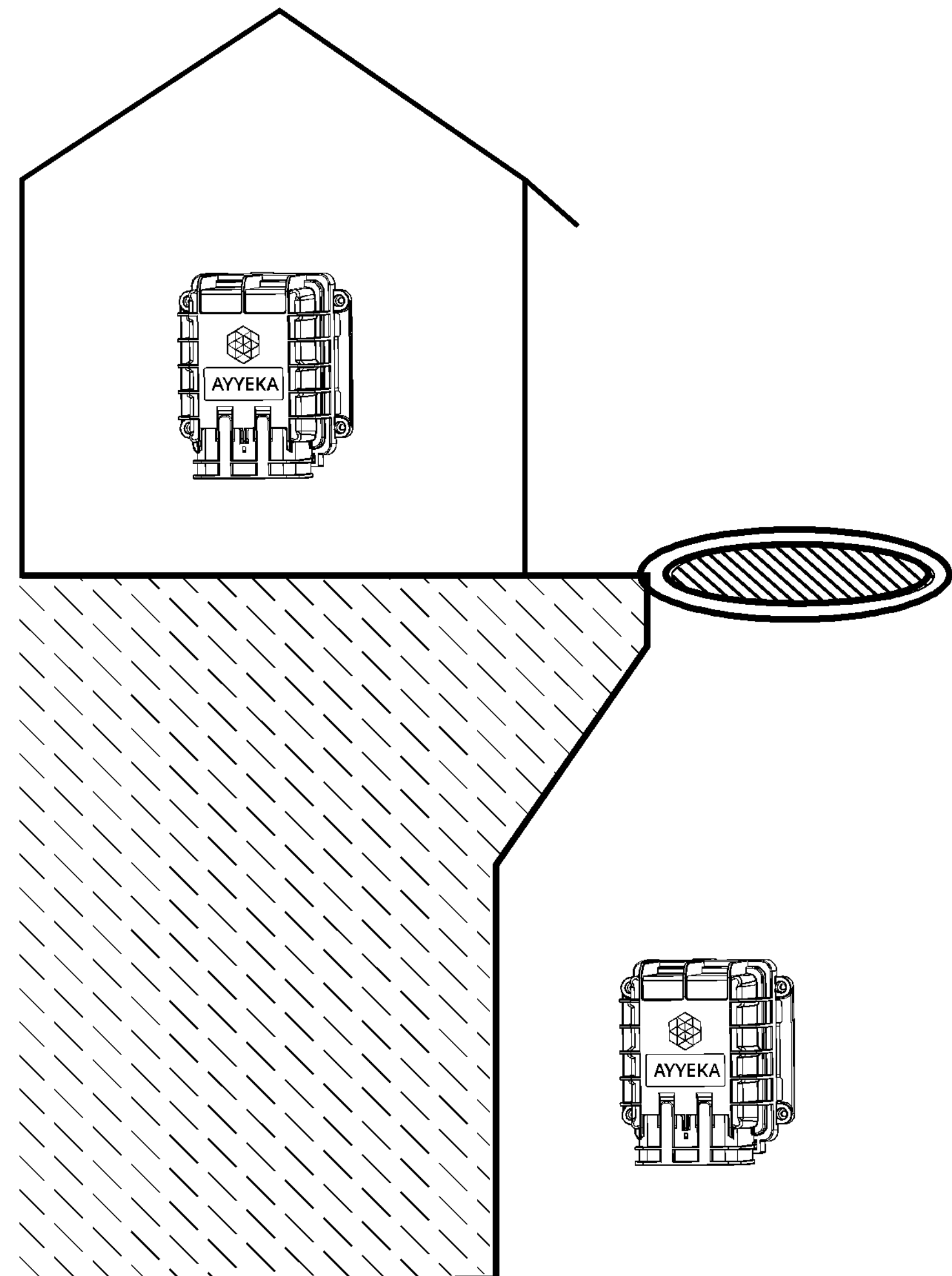
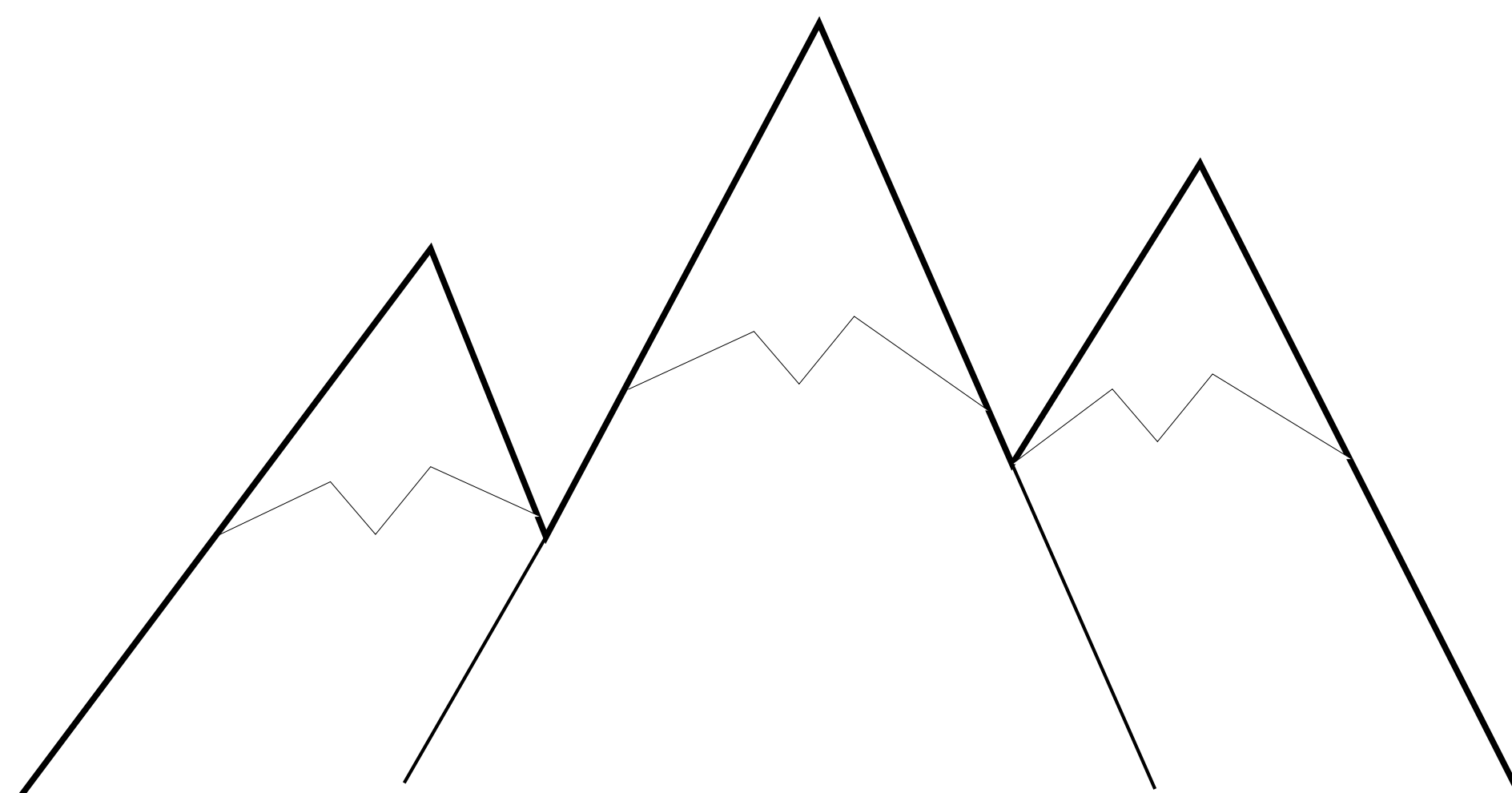
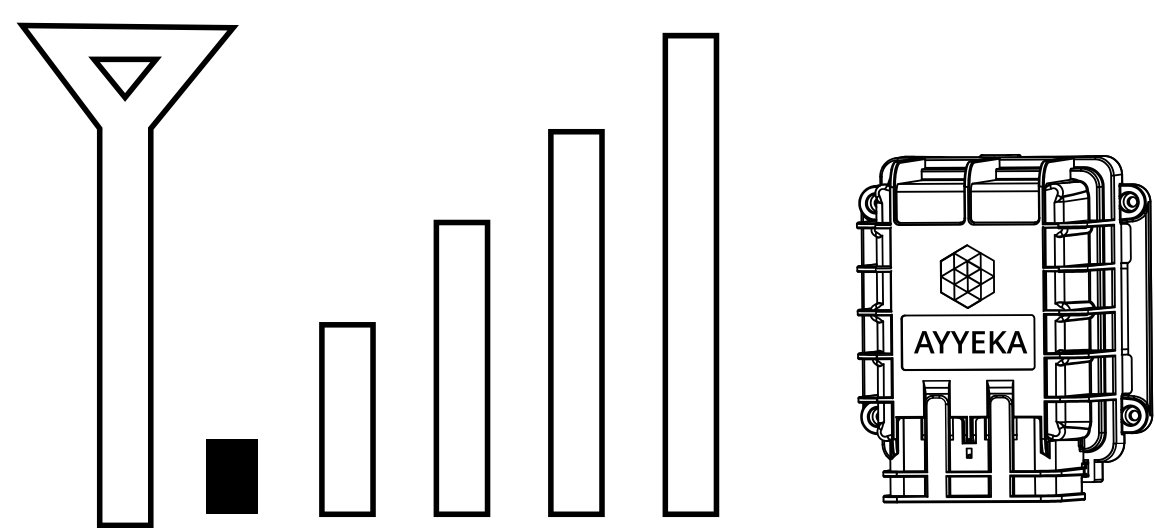

If the device is installed in an area with weak cellular signal, activate the Wavelet using the magnetic activator key.

Use the mobile app to pair with the device and confirm transmission. You can also log into the user interface using your credentials to validate that the device is transmitting and sensor sampling.

Wait for at least 15 minutes, then log into the user interface at <https://home.ayyeka.com> to confirm successful transmission.

If the device is installed in an area with weak cellular signal, activate the Wavelet and place in the intended installation location with closed doors/access hatch.

Wait for at least 15 minutes, then log into the user interface at <https://home.ayyeka.com> to confirm successful transmission. Before installation, initiate the GPS by activating the device.

# EXTERNAL POWER CONNECTION



## DANGER

Use extreme caution. Installation of through-the-wall connectors must be performed with proper tools for a hazardous location. Failure to conform with this warning may result in death or serious injury.

6

Prepare the site for the optional external power connections to be made through the wall from the hazardous location Zone 0 enclosure area to the unclassified location using the external DC connector and harness.

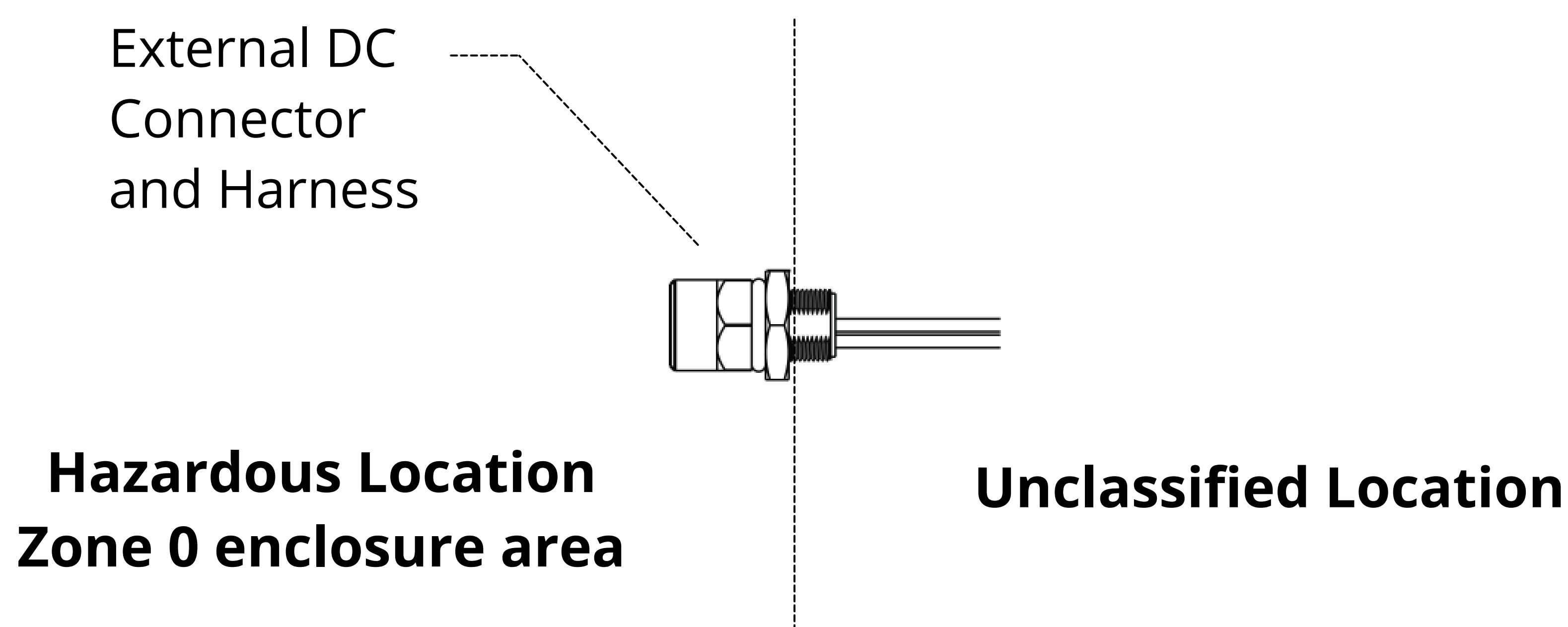

Locate the M8 3-pin male power panel connector on the device.

M8 3-Pin Male External Power Port

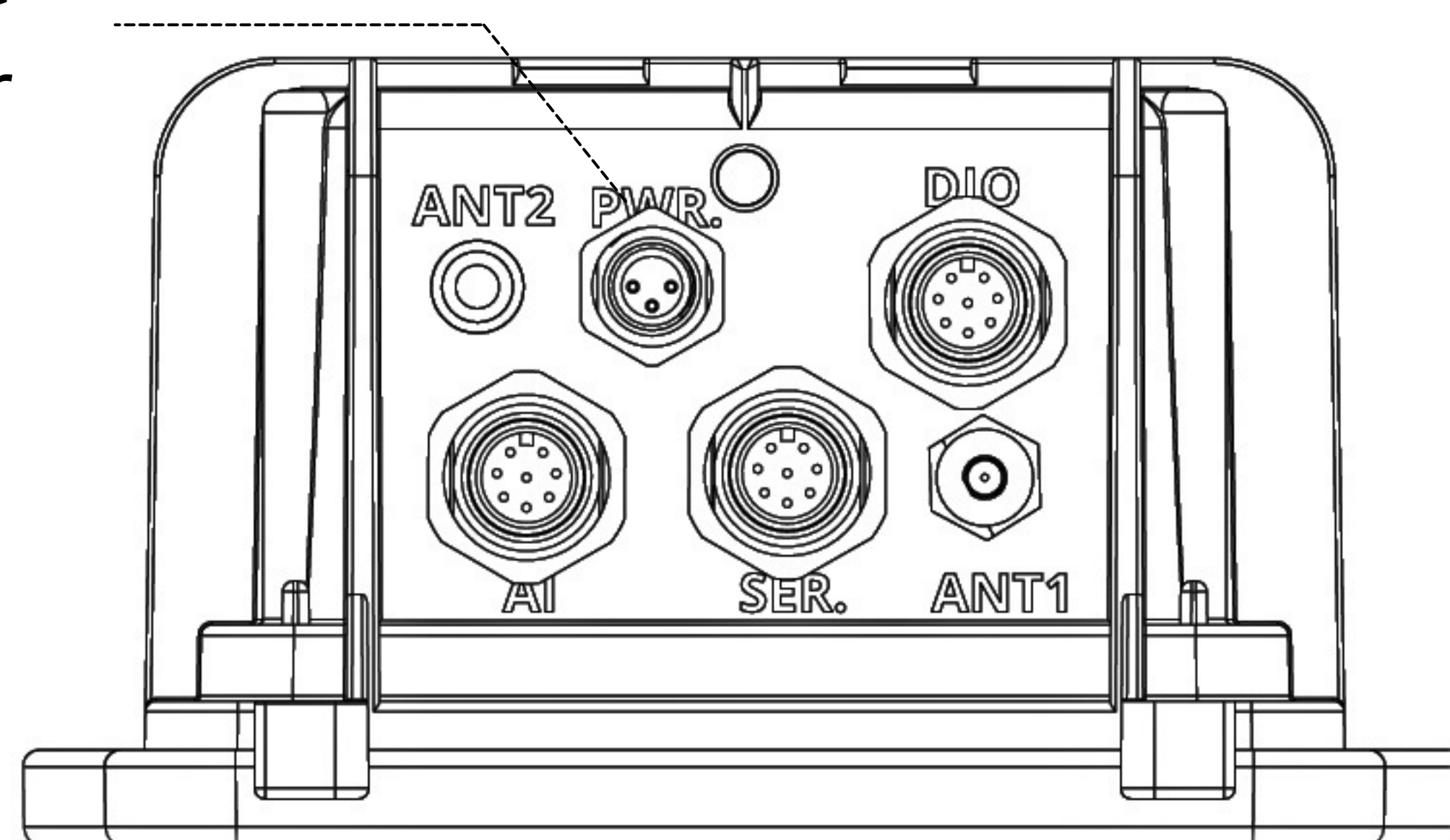

# EXTERNAL POWER CONNECTION



## DANGER

Use extreme caution. Do not disconnect/reconnect the unit after installation while power is on internally and/or externally. Failure to conform with this warning may result in death or serious injury.

7

Connect the M8 3-pin female to M8 3-pin male cable assembly. The M8 3-pin female connector is connected to the device panel connector (PWR port). The M8 3-pin male connector is connected to the external DC connector and harness.

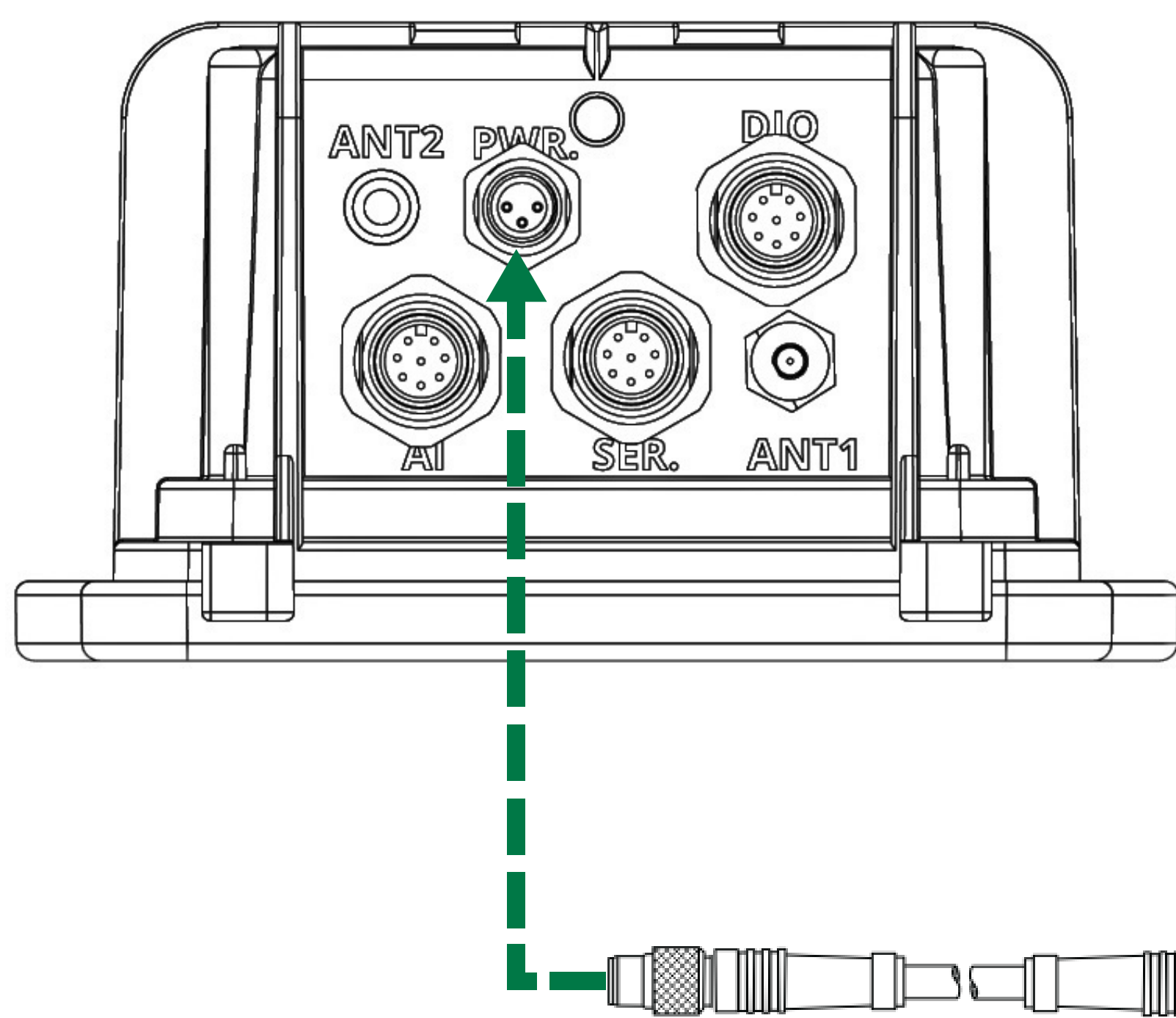

M8 3-Pin Female to  
M8 3-Pin Male Cable Assembly

**Hazardous Location  
Zone 0 enclosure area**

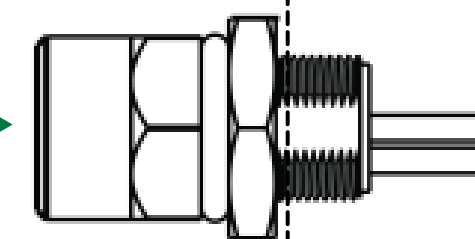

The Ex Wavelet works with an internal battery, and has an optional connection for an external power supply.

An external power supply connection requires using special safety barrier and cannot be connected directly to the device.

For operating the device on external power supply, please consult with an Ex technical expert.

**Unclassified  
Location**

# PANEL CONNECTOR PROTECTOR



## CAUTION

The panel connector protector is provided to shield the connections from tampering or overexposure that could result in disconnected wiring. Failure to properly attach and secure the protector to comply with Ex restrictions may result in death or serious injury.

8

After all sensor, power, and antenna connections to the device panel connector have been complete, secure the panel connector protector. Place the device protector above the connector ports and secure the device protector into the device enclosure.

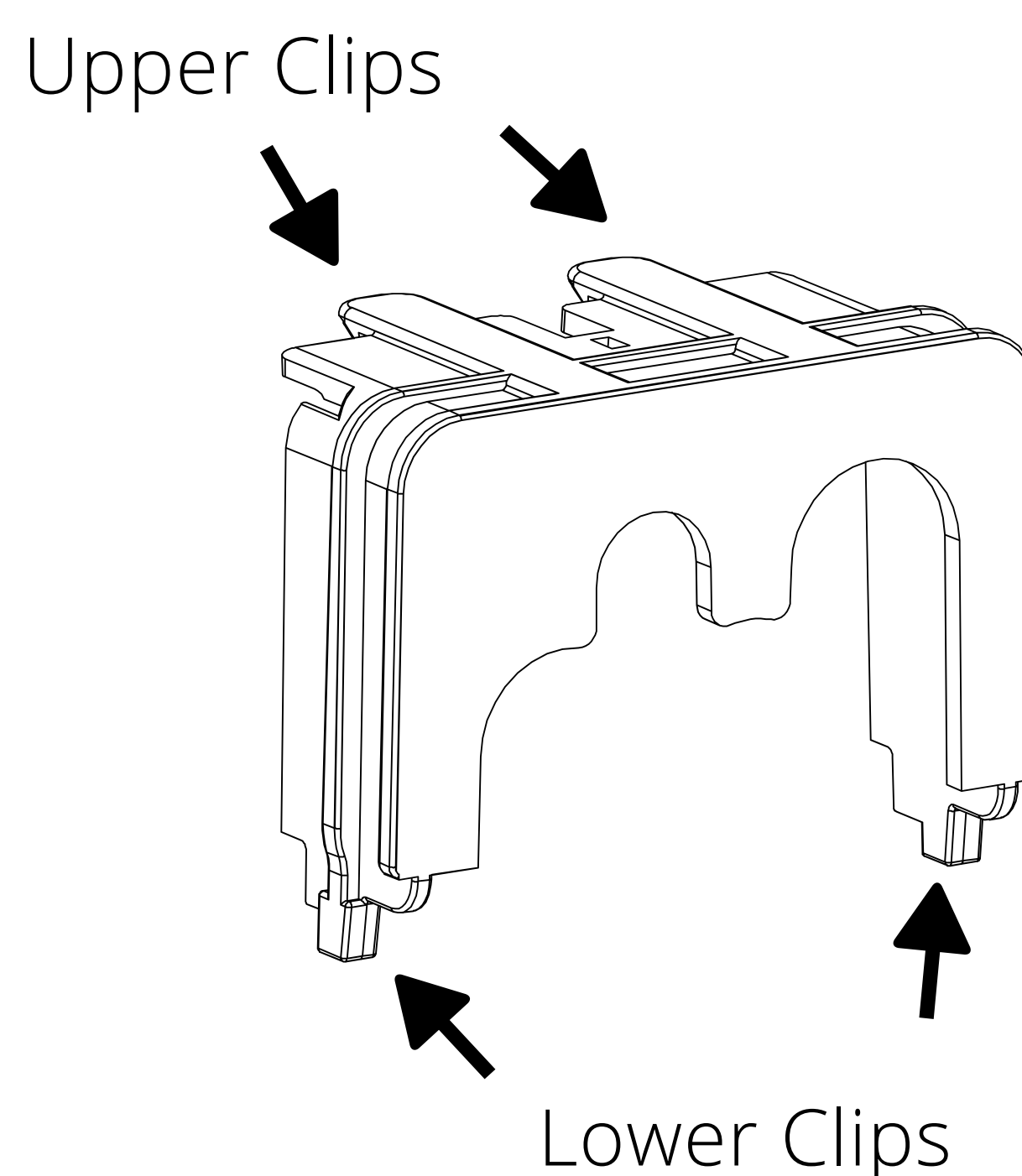

- a. Insert the two lower clips into the two lower holes of the device enclosure.
- b. Snap the upper clips into place in the two grooves above the panel connector.

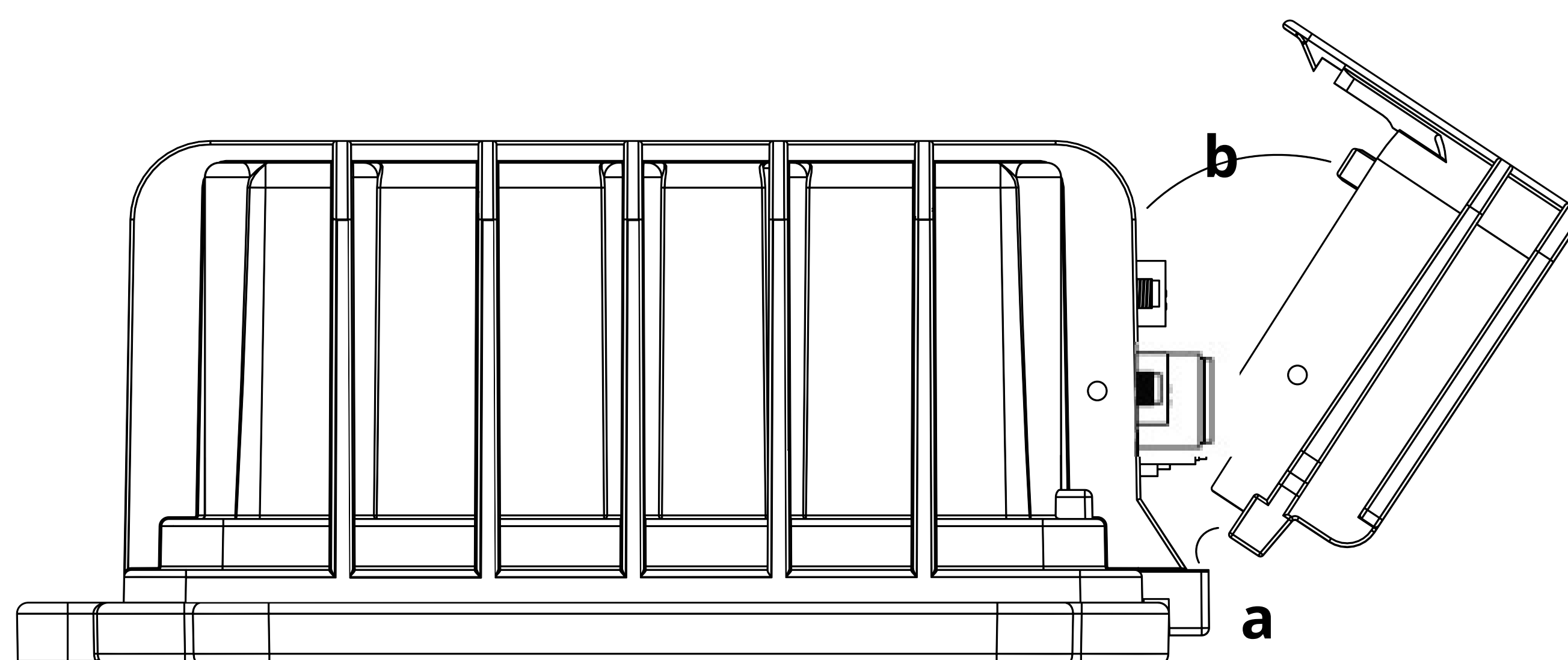



# PANEL CONNECTOR PROTECTOR



## CAUTION

The panel connector protector is provided to shield the connections from tampering or overexposure that could result in disconnected wiring. Failure to properly attach and secure the protector to comply with Ex restrictions may result in death or serious injury.



## DANGER

Use extreme caution. Secure the screw with proper tools for a hazardous location. Failure to conform with this warning may result in death or serious injury.

After the protector has securely snapped into place, insert and tighten the security screw to lock the panel connector protector. Do not over-tighten the screw.

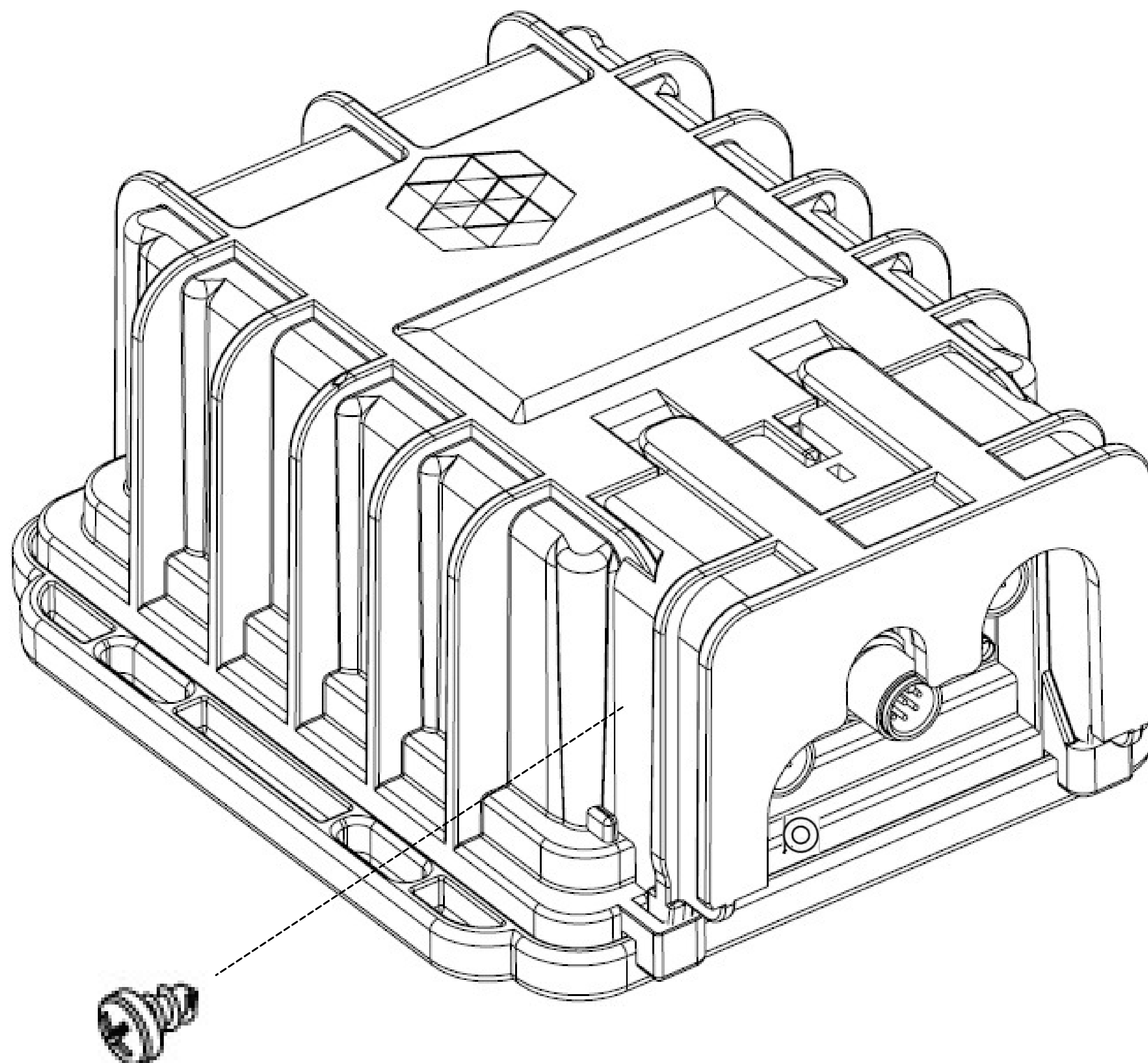

# DEVICE MOUNTING

9

Secure the device on a wall, pipe, or other secure mount location by using zip ties or screws.

Wall Mounted

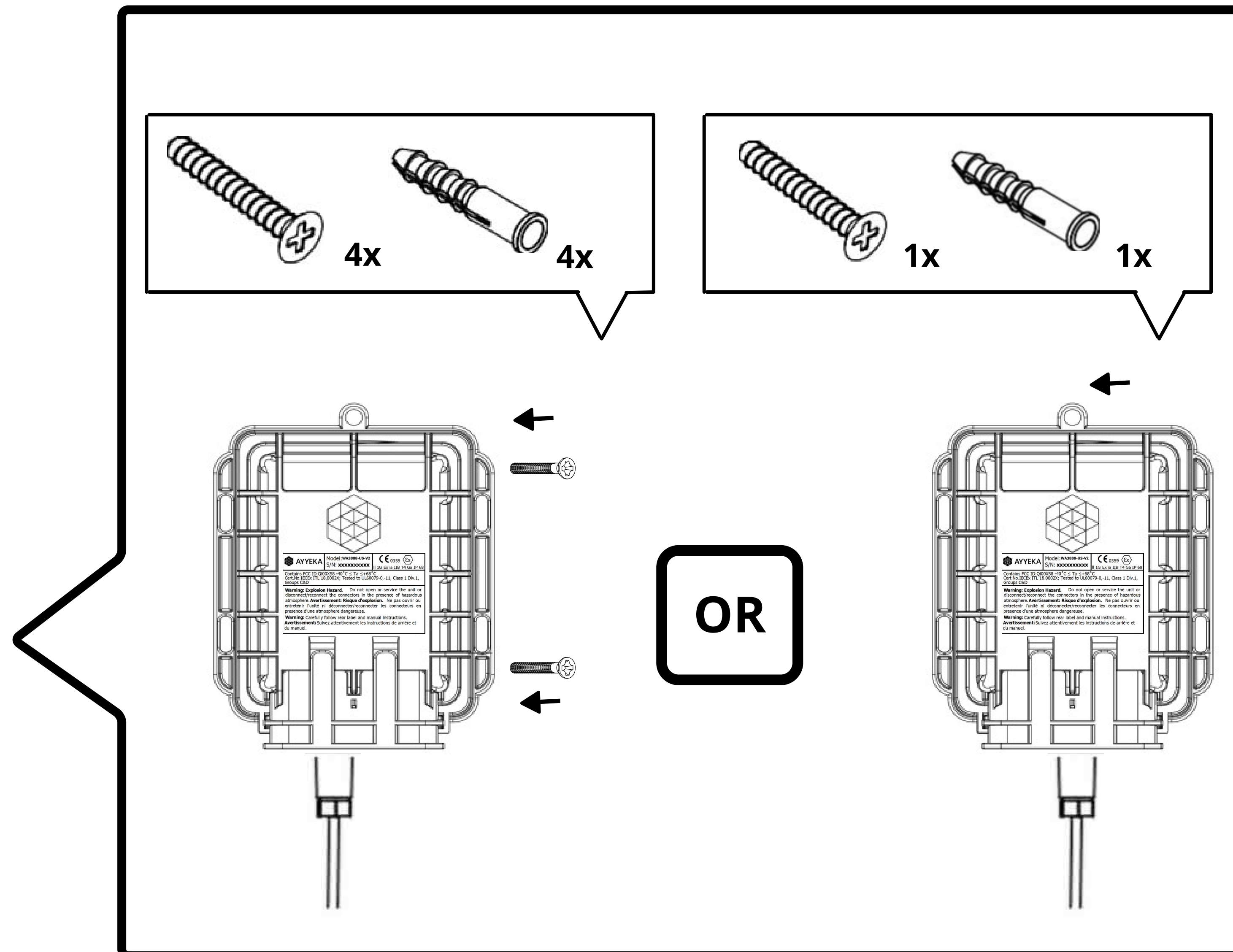

Pipe Mounted

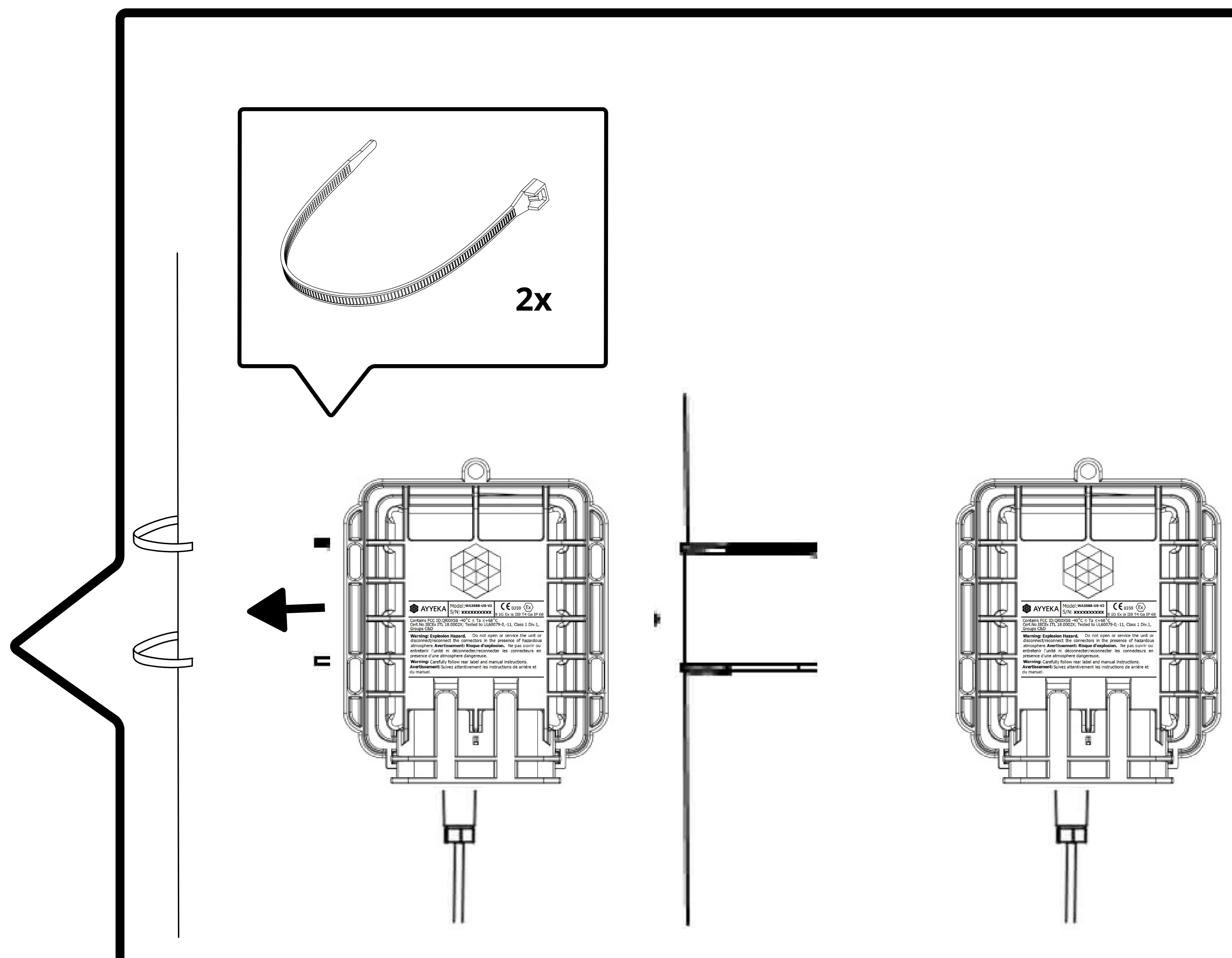

# ANTENNA MOUNTING

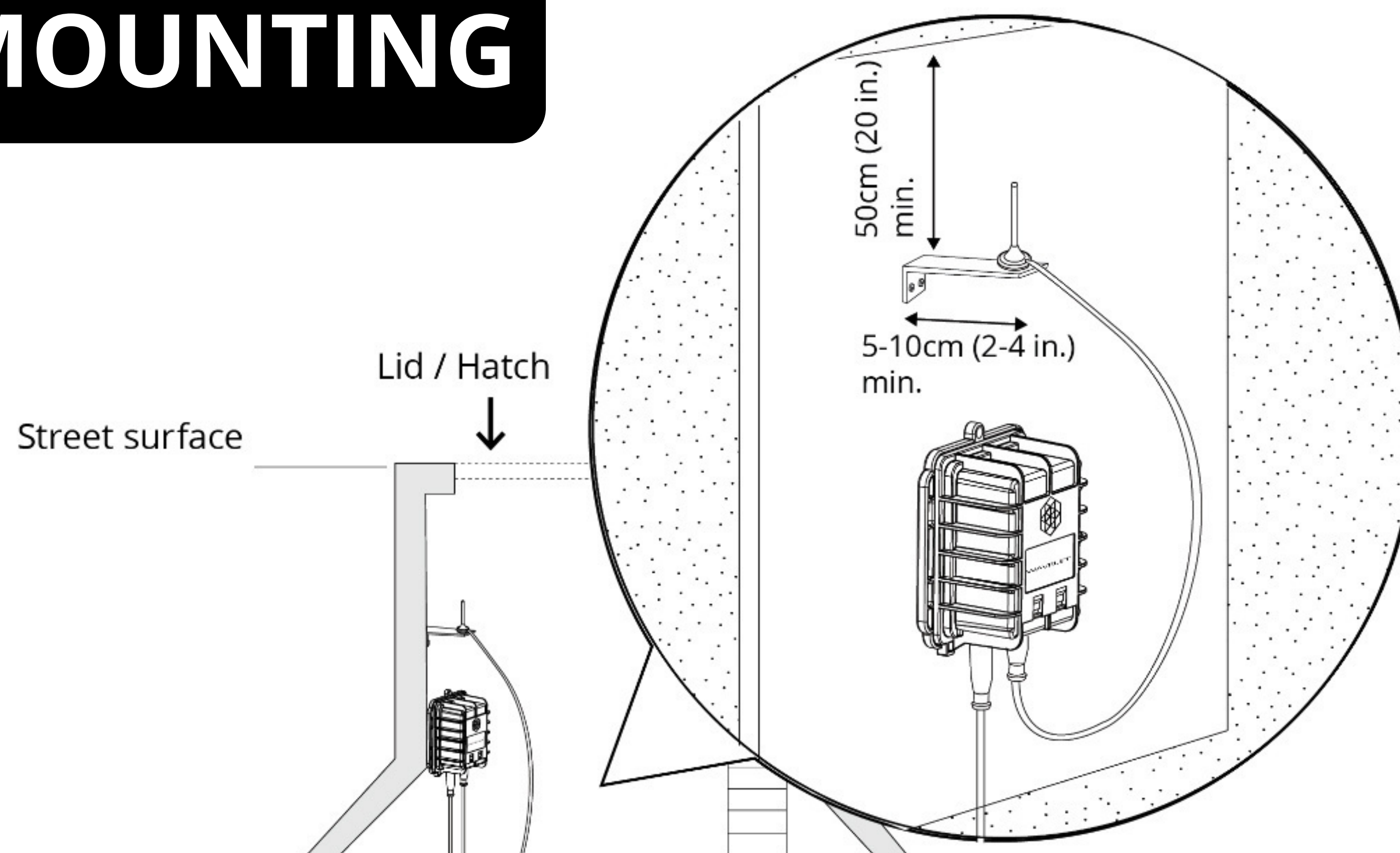

## **DOs**

- ✓ Ensure the antenna connector is secured tightly to the panel connector.
- ✓ Mount antenna under the open sky or at least 50cm (20in.) beneath any object.
- ✓ Mount antenna at least 5 to 10cm (2 to 4in.) away from wall.
- ✓ Mount antenna at least 5cm (2in.) away from the device.
- ✓ Finalize the antenna setup to the exact physical conditions. For example, close the lid, close the door, etc.
- ✓ Make sure you have a signal and a successful data transmission by using the mobile app.
- ✓ If needed during installation, use the Transmit Now command in the mobile app or the magnetic device activator key to initiate more rapid transmissions.

## **DONTs**

- ✗ Do not attach the antenna to the Wavelet.
- ✗ Do not wrap cables, zip ties, or other items around the antenna.

**IMPORTANT NOTE:** There are a few-minutes of delay between a successful transmission and the use of either of these methods for initiating data transmission. Repeating the use of either method will not expedite data transmission.

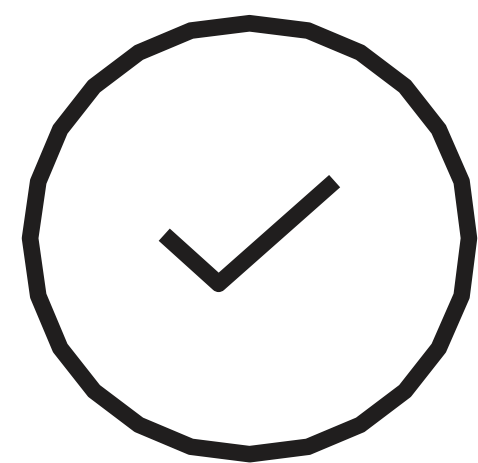

**WARNING:** If installing in a highly corrosive environment such as a sewer, apply technical grease to the antenna and sensor field attachable connectors after securing them to the panel connectors. Ayyeka recommends using Dow Corning Molykote 55 O-Ring Grease, though similar products can be effective.

**YOUR DEVICE  
IS SUCCESSFULLY INSTALLED!**



# DEVICE PINOUT – PORT #1

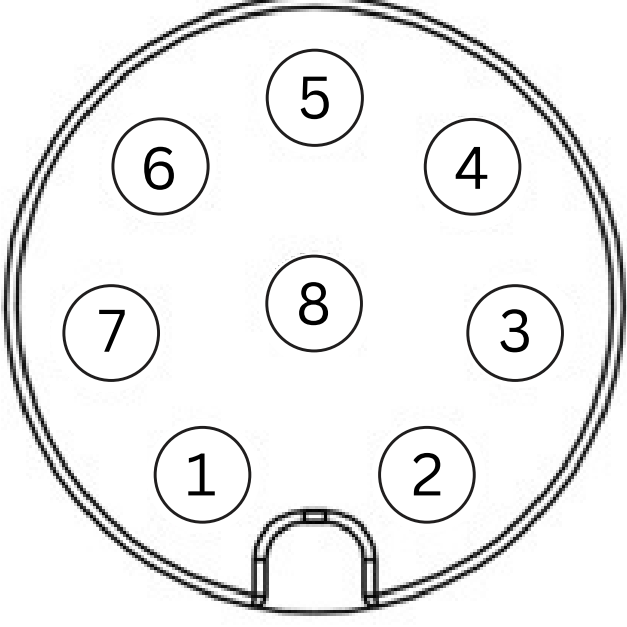

## M12 8-pin male panel connector

Connector pin #	Signal	Cable Connector Pin Assignment	
		Front Front	Back Back
1	4-20mA or 0-24V Input #1		
2	PCNT_0 – Pulse counting, periodic output dry contact, open drain, 0V or 2.8V (max)		
3	RS485A		
4	Wavelet 12V Power Supply #1 (+)		
5	RS485 B		
6	RS232 RX		
7	RX232 TX		
8	GND		

# DEVICE PINOUT – PORT #2

## M12 8-pin male panel connector

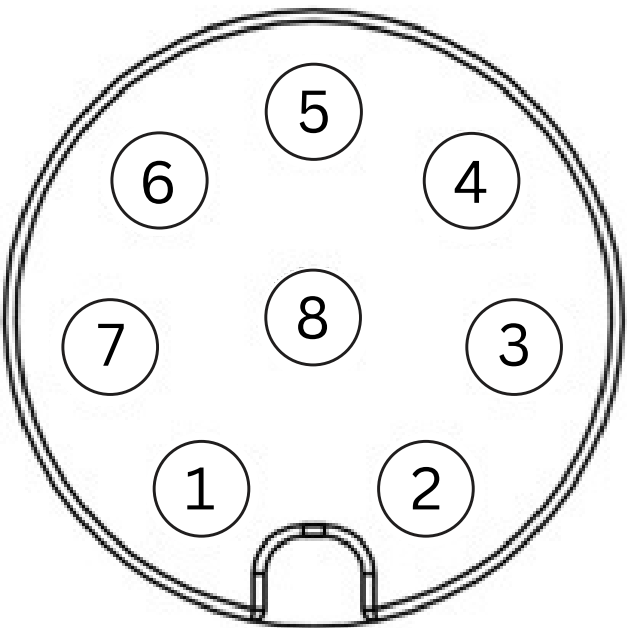

Connector pin #	Signal	Cable Connector Pin Assignment	
		Front	Back
1	4-20mA or 0-24V Input #2		
2	PCNT_1 – Pulse counting, periodic output dry contact, open drain, 0V or 2.8V (max)		
3	RS485A		
4	Wavelet 12V Power Supply #2 (+)		
5	RS485 B		
6	SDI-12		
7	IO_3 – periodic or output dry contact, open drain, 0V or 2.8V (max)		
8	GND		

# DEVICE PINOUT – PORT #3

## M12 8-pin male panel connector

Connector pin #	Signal	Cable Connector Pin Assignment	
		Front	Back
1	4-20mA or 0-24V Input #3		
2	IO_2- edge, periodic output dry contact, open drain, 0V or 2.8V (max)		
3	RS485A		
4	Wavelet 12V Power Supply #3 (+)		
5	RS485 B		
6	SDI-12		
7	IO_4 – periodic or output dry contact, open drain, 0V or 2.8V (max)		
8	GND		

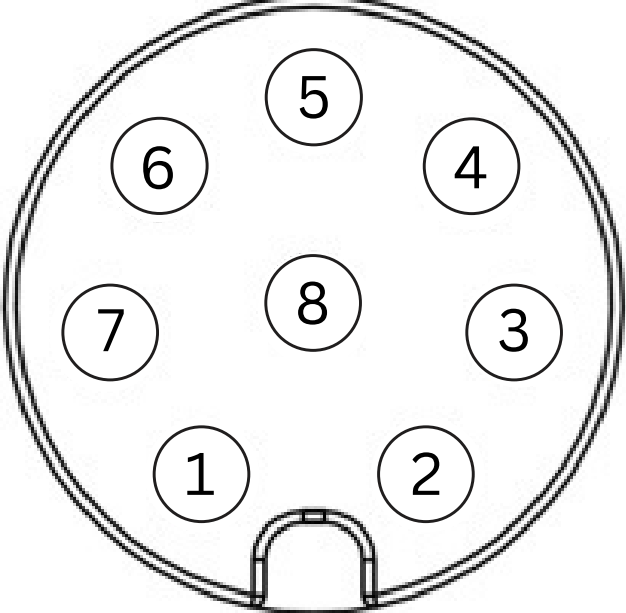
# DEVICE PINOUT – PORT #4

## M8 3-pin male panel connector

Connector Pin #	Signal	Cable Connector Pin Assignment	
		Front	Back
1	6-12VDC		
3	No Connection		
4	Negative (-)		



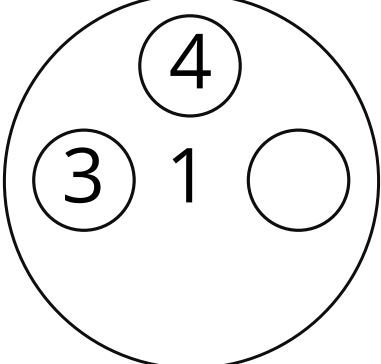
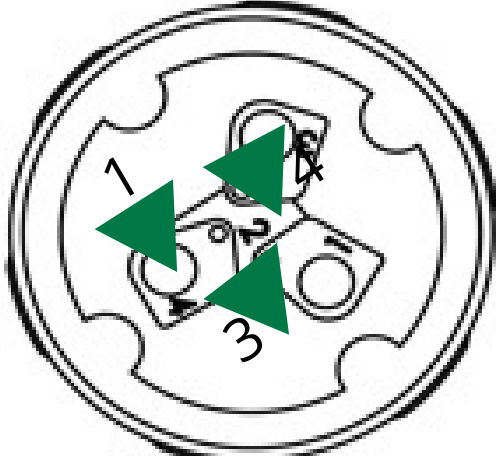

# WIRING INSTRUCTIONS

## DANGER

Use extreme caution. Do not disconnect/reconnect the unit after installation while power is on internally and/or externally. Failure to conform with this warning may result in death or serious injury.

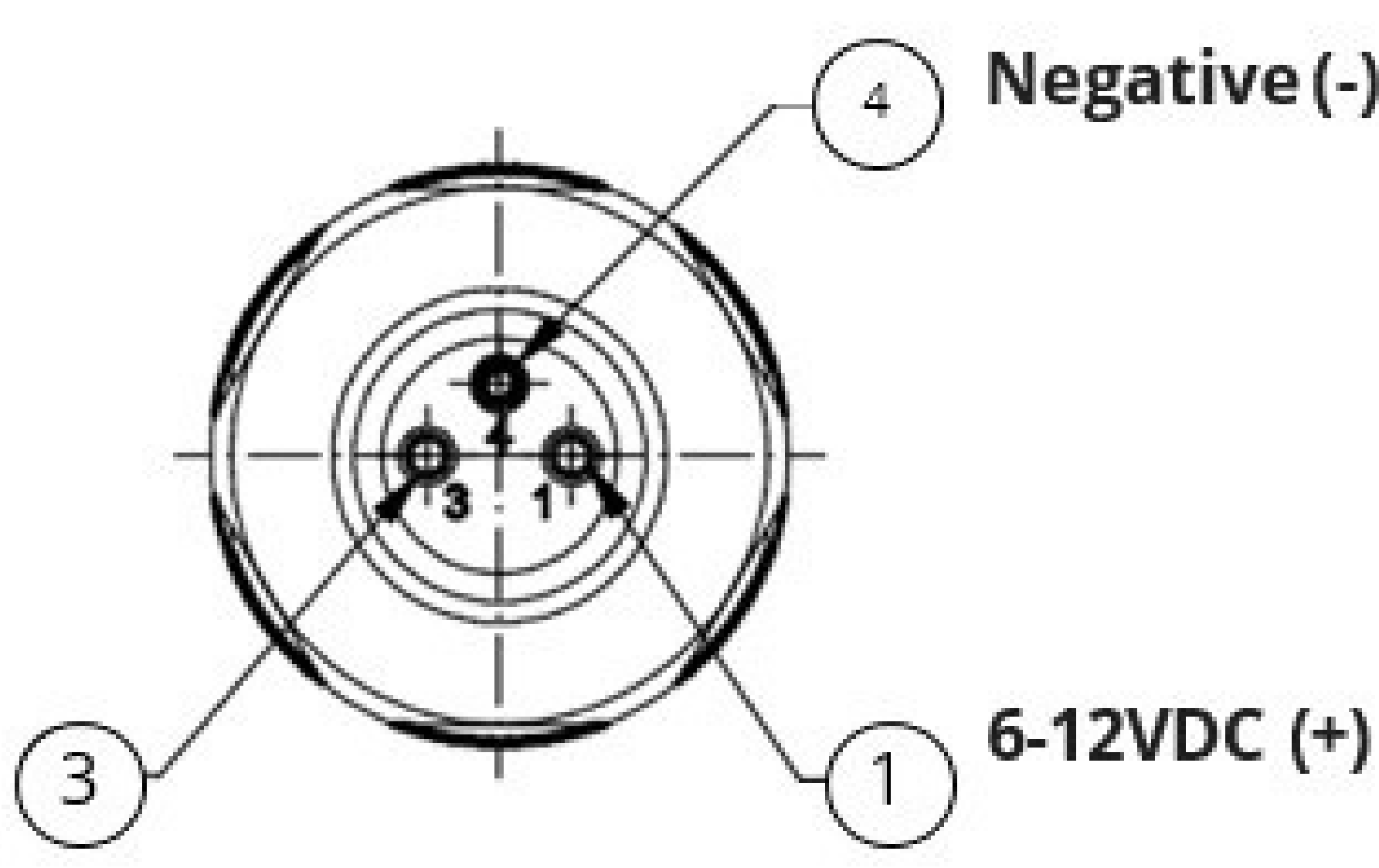
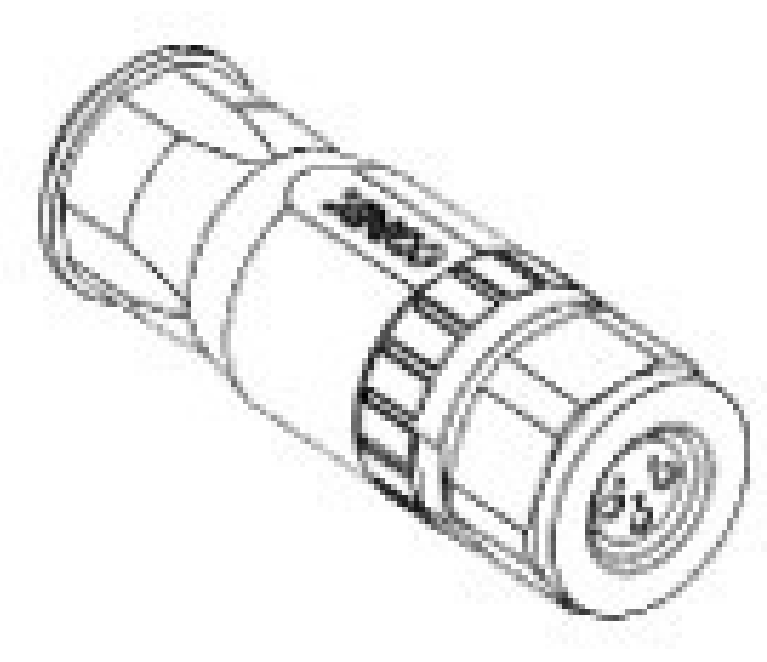
If you want an external power connection, refer to the instructions below.



Installation tool for wire termination (included)

SW 0,9

**No Connection**

**Wires to connect:**

Cable wire cross selection surface area	0.14 – 0.5 mm <sup>2</sup>
Wire gauge	AWG 20 -26
Cable diameter (Ø)	4 – 5.5 mm



For Sales & Service Contact

**geotech**

2650 E. 40th Ave. • Denver, CO 80205  
Phone 303-320-4764 • Fax 303-322-7242

**1-800-833-7958**

**[www.geotechenv.com](http://www.geotechenv.com)**